



EXELTECH

7317 Jack Newell Blvd. North
Fort Worth, Texas 76118-7100
817-595-4969 voice, 817-595-1290 fax
800-886-4683 toll free
website www.exeltech.com



Manufacturer of UL Listed Products

TL9000

Copyright © 2010 Exeltech Inc. All rights reserved. This Document may not be copied, photocopied, reproduced, translated or converted to any electronic or machine-readable form in whole or in part without prior written approval of Exeltech Inc.

Exeltech, Inc.
7317 Jack Newell Blvd North
Fort Worth, Texas 76118-7100

Table of Contents

Introduction 1.0	<i>page 3</i>
Standard Features 2.0	<i>page 5</i>
Installation 3.0	<i>page 8</i>
Operation 4.0	<i>page 11</i>
Appendix A	<i>page 12</i>
Appendix B	<i>page 14</i>
Appendix C	<i>page 16</i>



Introduction

1.0

Thank you for purchasing the finest sine-wave inverter in the power conversion industry. Exeltech's journey to excellence includes the first affordable sine wave inverter, first modular inverter system, first N+1 redundant inverter system, and the cleanest sine wave output in the industry. Exeltech strives to manufacture products of the highest possible quality, and is dedicated to 100% customer satisfaction. Proudly built in the USA with American parts, Exeltech is committed to TL 9000 standards and beyond, adding people and procedures continually to further improve quality and customer service. We welcome you as a customer to the Exeltech family. Congratulations!

XP series inverters provide the cleanest, best regulated sine wave output over the widest DC input of any inverter on the market today. They are extremely low in Total Distortion; specified to 2%, and typically better than 1.5%. Total Harmonic Distortion is typically 0.8 to 0.9%. Remaining distortion is a result of residual switching noise, which amounts to a 25 kHz sine wave superimposed on the fundamental output. No significant harmonics of 25 kHz exist. This spectral purity will exist over the inverter's entire operating envelope, including non-linear and reactive loads. As long as peak output current remains less than 280% of rated current, total harmonic distortion will remain within the 2% spec. Peak current capability of the inverter is key to understanding its operational envelope. As long as the inverter is supplying less than this amount, it will function properly and operate virtually any load.

Many inverters are rated in Volt-Amps (VA), as opposed to Watts. This is in an attempt to make an inverter or UPS (Uninterruptible Power Supply) appear larger than it really is. The only fair way to

specify these products is in watts (W), which is power the inverter can actually deliver. If Exeltech inverters were specified in VA, our 1100 watt inverter could be rated at 1375 VA @ 0.8 power factor, 1570 VA @ .7 pf, or an incredible 2200 VA @ 0.5 pf.; and our 2000 watt inverter could be rated at 2500 VA @ 0.8 pf., 2857 VA @ 0.7 pf, or an incredible 4000 VA @ 0.5 pf. It is confusing to specify a product in VA, because the power factor must also be specified.

The inverter can maintain a spectrally pure output with any load, due to a specially designed non-linear control loop in the primary DC to DC converter. This circuitry is one of three circuits which protect the inverter from any overload condition.

XP-600, XP-1100 and XP-2000

These inverters can supply twice their rated output power for 3 seconds, in order to start motors or supply in-rush currents to electronic loads. If output power is exceeded for greater than 3 seconds, output voltage is reduced to a level which will provide the inverter's rated power to the load by clipping tops of the waveform. The inverter can operate safely in this mode indefinitely. Exeltech's XP-Series inverters can output their full rated power continuously at 30°C (86°F). The inverter is derated 20% of its full power for every 10°C over 30°C. IE; 80% of normal capacity at 40° C, 60% at 50° C . . . Etc.



Standard Features 2.0

DC INPUTS: Positive (+) and Negative (-) input terminals are 3/8" studs with brass hardware. They are accessed under the rear cover. Use "Appendix A" to choose the appropriate gauge wire for your specific model.

REMOTE ON/OFF: Provides the user with a remote method to turn the inverter on and off. "REMOTE" connection is on the barrier terminal strip located under the rear cover.

AC OUTPUTS: All domestic models have two NEMA - 15 outlets (standard wall receptacle), and NEMA -Wd6 outlets (T slot, 5-20R receptacle) on XPX. These are located on the front panel of the unit. XP-600, XP-1100 and XP-2000 230 VAC inverters will have an IEC-320 receptacle located on the front panel. Additionally, the unit may be hard-wired to appliance/load using connections on the barrier terminal strip, located under rear cover.

COOLING: Provided by a thermostatically controlled brushless fan located on the front panel.

DC POWER ON LED: Located on the front panel, will be "ON" when inverter is powered up, and DC power is available.

LOW BATT / THERM BUZZER: Produces an audible alarm if DC input voltage falls to a level within 2% to 4% of the low limit of inverter, or, if there is an over temperature condition.

ON/OFF SWITCH: Located on front panel; turns the inverter on and off.

OVER VOLTAGE PROTECTION: When input voltage to the inverter exceeds set limits, the inverter will immediately and without warning shut off. When input voltage returns to normal range, the inverter will immediately restart. Since high over voltages tend to have very fast edges, the inverter must shut down quickly to protect itself. This kind of fault usually occurs if the battery is suddenly disconnected from the system and the battery charger continues to supply current.

UNDER VOLTAGE PROTECTION: When battery voltage falls to within 2% to 4% of low line voltage, the LOW BAT/THERM buzzer will sound. If the condition continues without reducing load to the inverter or adding charge to the battery, the inverter will shut off. When voltage rises to approximately 85% of nominal battery voltage the inverter will turn back on and the alarm condition will clear. The inverter can be manually reset by cycling the on/off switch. This will reset the protection circuit and turn the inverter on at any voltage above minimum voltage.

OVER TEMPERATURE PROTECTION: The inverter is also protected against overheating. It will provide its full rated output up to the temperature listed in the specification sheet. If it is subjected to higher ambient temperatures or air circulation is blocked, the inverter may overheat. If the LOW BATT/THERM buzzer sounds, immediate action is required or the inverter will shut down. Either reduce load, or provide more cooling in the immediate environment. If no action is taken, the inverter will likely shut down within 2 minutes. When the inverter shuts down, the alarm condition will persist and the cooling fan will continue to run. Since the inverter has eliminated its load, it will cool fairly quickly. It will automatically restart when it has cooled sufficiently, and the LOW BATT/THERM alarm will clear.

OVERPOWER, SHORT CIRCUIT PROTECTION: XP600/1100 inverters have three levels of overpower protection. The first limits peak instantaneous current. The second system limits absolute power coming from the module. Both of these circuits act to reduce output voltage as required, to limit current to a safe level. The overpower protection circuit will recover instantly when the overpower condition clears. The third, is short circuit protection. If the overcurrent condition is so severe that it causes output voltage to collapse to 1 Vp for more than 1 second, the inverter will shut down and not automatically restart. This requires the user to clear the short circuit safely, and guarantee that hazardous voltage will not come back on line until desired. To reset the inverter from this condition, cycle power switch "OFF" then "ON" again.

XP-2000 inverters will provide peak current (45 A) or maximum surge (4000W) for 3 seconds when the inverter's internal temperature is at or below 25° C. The output current is then reduced to 16.7A (rated power) for 4 secs. If the inverter cannot restore a full sine wave due to overload, the LED will be red. If the overload condition does not clear in 7 secs., the inverter shuts off (flashing red indicator).

LED STATUS (For XP2000):

- Solid Green (Inverter "ON")
- Solid Orange (Over Temperature Warning)
- Flashing Orange (Over temperature)
- Solid Red (Overload Warning condition)
- Flashing Red (Overload condition)



Installation

3.0

CAUTION: It is essential to read and understand all Warnings, Cautions, and Notes before any connections are made to the unit or system. If further assistance is needed call (817) 595-4969 and ask for Customer Service.

ATTENTION: Il est essentiel de lire et de comprendre tous les Avertissements, Attentions et des Notes avant les connexions sont faites à la unité ou du système. Si une assistance supplémentaire est nécessaire composez le (817) 595 - 4969 et demandez pour le service client.

WARNING: The inverter is designed to operate from a Battery. Performance cannot be guaranteed, and damage can result when a charger or power supply is used without a battery in the circuit.

AVERTISSEMENT: L'onduleur est conçu pour fonctionner à partir d'une batterie. Performance ne peut pas être garantie, et peut entraîner des dommages quand un chargeur alimentation est ou le pouvoir est utilisé sans batterie dans le circuit.

WARNING: The AC neutral lead is bonded to chassis through the barrier terminal strip connector located on the back of unit. The chassis must be connected to ground.

(See Appendix C)

AVERTISSEMENT: L'AC neutre de plomb est relié au châssis par le biais le bornier de raccordement situé à l'arrière de l'unité. Le châssis doit être lié à la terre.

(Voir Annexe C)

The Negative or Positive terminal of the battery (DC Source) must be bonded to earth ground. It's recommended that it be to the same earth ground used for AC ground.

La borne négative ou positive de la batterie terminal doit être lié à la terre. Il est recommandé qu'il soit mis fin à la même point utilisé pour le AC sol.

CAUTION: Before any connections are made to the unit or system, be sure to disconnect the battery terminals. Always disconnect the grounded battery terminal first. Reconnect the grounded terminal last.

ATTENTION: Avant toute connexion n'est faite à l'unité ou système, veuillez à débrancher les bornes de la batterie. Toujours débrancher la borne reliée à la terre première fois. Rebranchez la borne terre dernier.

CAUTION: Polarity of leads is critical to avoid damage to the unit or system. Check batteries and battery cables for correct polarity and voltage.

ATTENTION: Polarité de conduit est essentielle pour éviter d'endommager l'appareil ou système. Vérifiez la polarité et la tension.

CAUTION: Observe all National and Local Electric Codes when connecting AC Power Connections.

ATTENTION: Respecter toutes les électriques nationales et locales Codes lorsque raccordement Alimentation secteur.

INSTALLATION (Location)

Mounting location is critical to performance and life span of the inverter. Heat and moisture are the two worst enemies of any electronic device. Therefore, when choosing a mounting location, consider the following requirements listed in order of importance:

- 1.** Inverter must be sheltered from the elements. Select a clean, dry location.

2. Inverter requires adequate ventilation for cooling. With proper cooling, the inverter will operate efficiently and meet its published ratings. All models can be mounted in several positions. Best position, with fan down. Second best, horizontal. Third, vertical with fan up. Least preferred, upside down.

3. Inverter should be mounted as close to the battery as possible. Shorter wire has less resistance, which translates to increased efficiencies.

INSTALLATION (Wiring)

An in line fuse is recommended, to protect the battery and wiring to the inverter. This fuse should be located very close to the battery positive (+) terminal. To select appropriate size fuse, consult the "Rated and Peak Current" table in appendix "A".

1. Disconnect the **grounded** terminal of battery and make sure the charger and inverter are off.

2. Make DC input connections to the inverter as illustrated in "Appendix C".

3. (Optional) Using 12-18 AWG wire, make Remote On/Off connection from the rear panel terminal labeled "REMOTE" to one pole of a small toggle switch. Then from the other pole of toggle switch, make a connection to battery negative (-). Make sure the toggle switch is in the off position.

4. Reconnect grounded terminal of the battery.



Operation

4.0

TURN ON INVERTER:

XP-600, XP-1100 and XP-2000: Turn inverter on using Toggle Switch on Front Panel, or the "REMOTE" switch if installed. LED next to the switch will illuminate, indicating the inverter is operational.

Note: If using "REMOTE" switch, the Front Panel Switch must be off. (If either switch is "on", the inverter will turn on. Both switches must be off for the inverter to turn off.)

TURN ON APPLIANCE/LOAD:

1. Check Input Power Requirements of the appliance. Make sure that it is less than Rated Output Power of the inverter. If more than one appliance will be run simultaneously, the sum of their Input Power Requirements must be less than Rated Output Power of the inverter.

2. If Appliance/Load has been hard wired to the barrier terminal strip as illustrated in Appendix "C", then turn appliance on. Otherwise, plug the appliance into the provided receptacle on Front Panel, then turn appliance on.

Note: It is recommend that the inverter be turned ON before the appliance/load.

APPENDIX A

Input Power Requirements:

MODEL	NORMAL VDC	MINIMUM VDC CUT-OFF / ALARM	MAXIMUM VDC	RATED CURRENT AMPS	PEAK CURRENT AMPS
XP-600 / 12VDC	13.8 VDC	10.4 / 10.6 VDC	16.5 VDC	51.2 A	99.9 A
XP-600 / 24VDC	27.6 VDC	19.0 / 21.0 VDC	33 VDC	25.0 A	49.3 A
XP-600 / 32VDC	36.8 VDC	26.5 / 28.0 VDC	44 VDC	18.5 A	26.5 A
XP-600 / 48VDC	55.2 VDC	41.5 / 42.5 VDC	62 VDC	12.5 A	24.3 A
XP-600 / 66VDC	75.9 VDC	57.5 / 58.5 VDC	91 VDC	9.0 A	17.5 A
XP-600 / 108VDC	124.0 VDC	94.0 / 95.0 VDC	149 VDC	5.6 A	10.9 A
XP-1100 / 12VDC	13.8 VDC	10.4 / 10.6 VDC	16.5 VDC	93.8 A	219.8 A
XP-1100 / 24VDC	27.6 VDC	19.0 / 21.0 VDC	33 VDC	45.8 A	108.4 A
XP-1100 / 32VDC	36.8 VDC	26.5 / 28.5 VDC	44 VDC	34.0 A	80.4 A
XP-1100 / 48VDC	55.2 VDC	41.5 / 42.5 VDC	62 VDC	22.9 A	53.5 A
XP-1100 / 66VDC	75.9 VDC	57.5 / 58.5 VDC	91 VDC	16.5 A	38.5 A
XP-1100 / 108VDC	124.0 VDC	94.0 / 95.0 VDC	149 VDC	10.2 A	24.0 A
XP-2000 / 12VDC	13.8 VDC	10.5 / 10.8 VDC	15 VDC	193.2 A	450.0 A
XP-2000 / 24VDC	27.6 VDC	21.0 / 21.6 VDC	30 VDC	96.6 A	254.0 A
XP-2000 / 48VDC	55.2 VDC	42.0 / 43.2 VDC	60 VDC	48.3 A	127.0 A
XP-2000 / 66VDC	73.6 VDC	56.0 / 57.6 VDC	80 VDC	35.1 A	92.3 A

Note: Peak surge Amps occurs at surge wattage and low-line DC input.

XP600/1100/2000 INSTALLATION AND OPERATION MANUAL

OUTPUT POWER

CONTINUOUS POWER	SURGE POWER	NO LOAD POWER	OUTPUT VOLTAGE	OUTPUT CURRENT	WEIGHT LBS.
600W	1100W	8W	100 +/-6%	6.0	6.5
600W	1100W	8W	117 +/-6%	5.1	6.5
600W	1100W	9W	230 +/-6%	2.7	6.5
1100W	2200W	20W*	100 +/-6%	11.0	10
1100W	2200W	20W*	117 +/-6%	9.5	10
1100W	2200W	20W*	230 +/-6%	4.8	10
2000W	3200W	12W	100 +/-2%	20.0	15
2000W	4000W	12W	120 +/-2%	16.7	15
2000W	4000W	12W	230 +/-2%	8.7	15

*12W with X2 option

Recommended Input Wire Sizes (For Variable Distances from the Battery):

MODEL	LESS THAN 5'	LESS THAN 10'	LESS THAN 15'	LESS THAN 20'
XP-600 / 12VDC	4 AWG	0 AWG	0 AWG	2/0 AWG
XP-600 / 24VDC	10 AWG	6 AWG	4 AWG	4 AWG
XP-600 / 48VDC	16 AWG	12 AWG	10 AWG	10 AWG
XP-600 / 66VDC	18 AWG	16 AWG	14 AWG	12 AWG
XP-600 / 108VDC	18 AWG	18 AWG	18 AWG	16 AWG
XP-1100 / 12VDC	0 AWG	2/0 AWG	3/0 AWG	3/0 AWG
XP-1100 / 24VDC	6 AWG	4 AWG	2 AWG	0 AWG
XP-1100 / 48VDC	12 AWG	10 AWG	8 AWG	6 AWG
XP-1100 / 66VDC	16 AWG	12 AWG	10 AWG	10 AWG
XP-1100 / 108VDC	18 AWG	16 AWG	14 AWG	14 AWG
XP-2000 / 12VDC	2/0 AWG	3/0 AWG	250mcm AWG	250mcm AWG
XP-2000 / 24VDC	4 AWG	0 AWG	2/0 AWG	3/0 AWG
XP-2000 / 48VDC	8 AWG	6 AWG	4 AWG	0 AWG
XP-2000 / 66VDC	12 AWG	8 AWG	6 AWG	4 AWG

Note: The table specifies standard wire sizes (not smaller than 18 AWG) that will provide less than a 2% voltage drop at Low-line Input voltage and Rated Output Power.

APPENDIX B

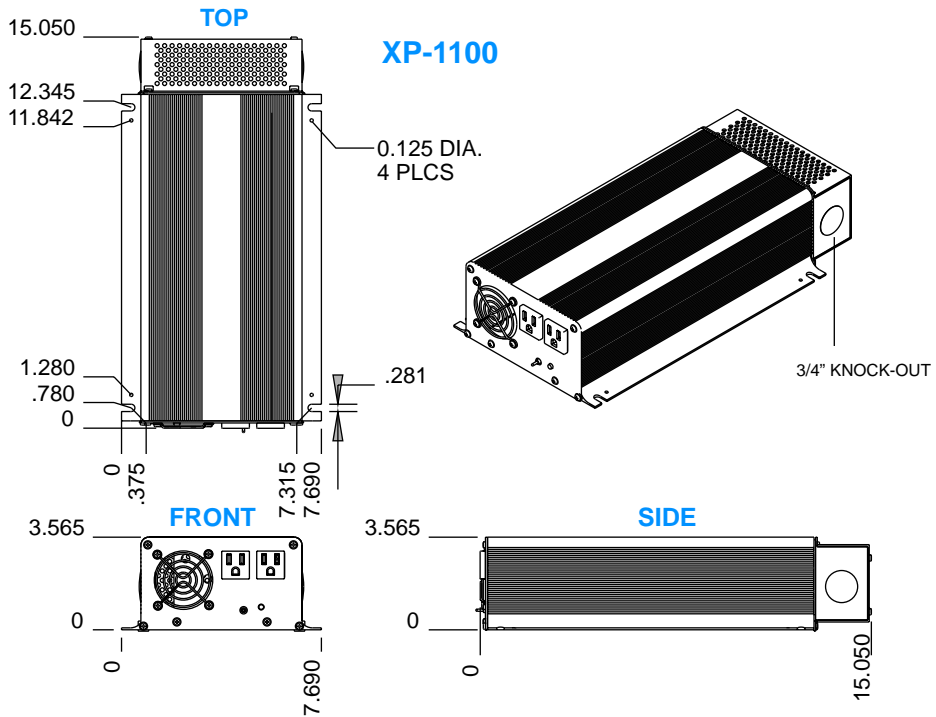
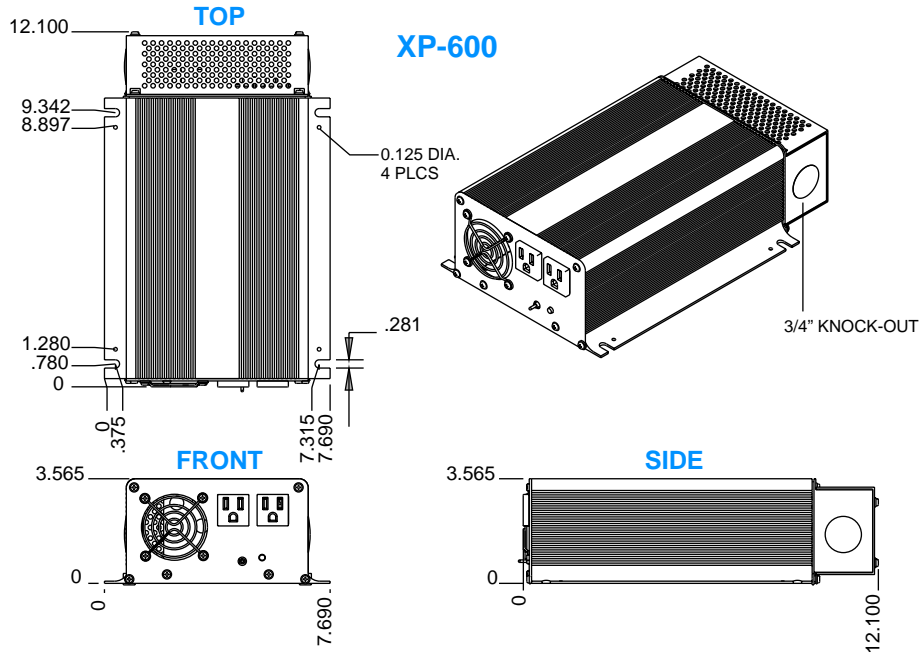

XP-2000

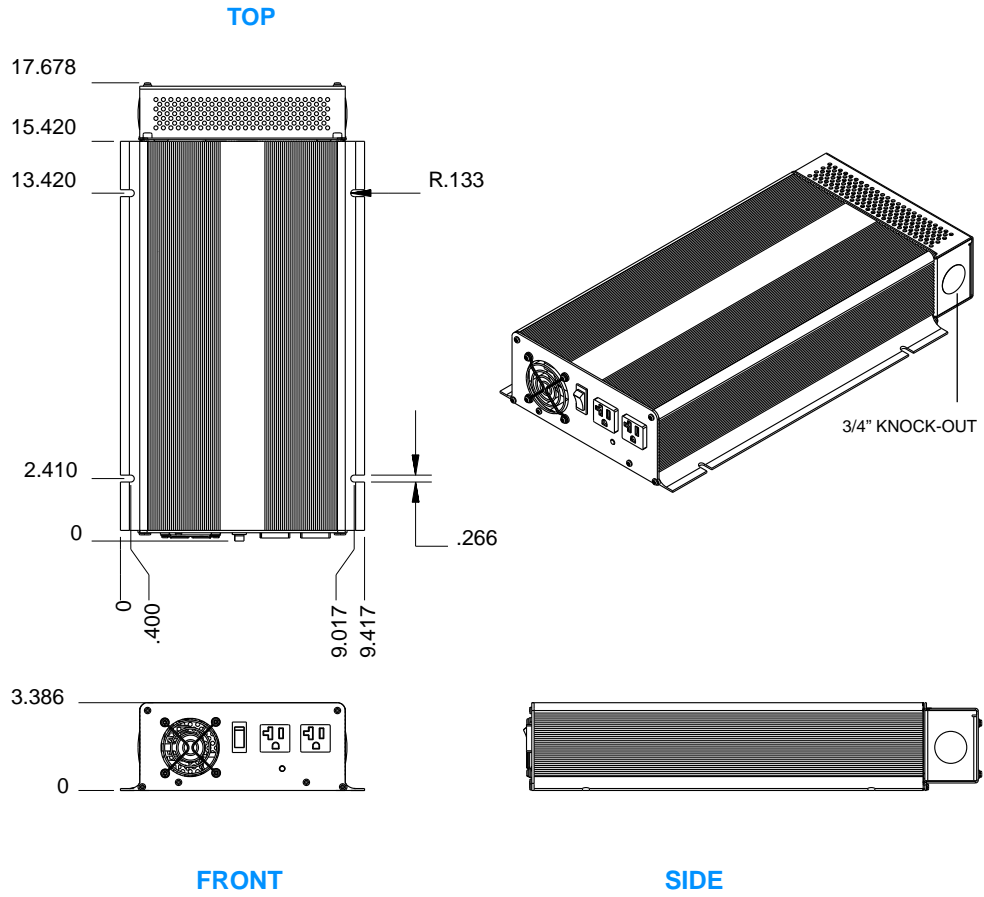

APPENDIX C

INSTALLATION

CAUTION: Terminate all connections to the inverter **BEFORE** connecting DC leads to the battery.

ATTENTION: Mettre fin à toutes les connexions à l'onduleur avant de brancher mène à la batterie.

XP-600 and XP-1100 Rear View with access cover removed (AC/DC Connections):

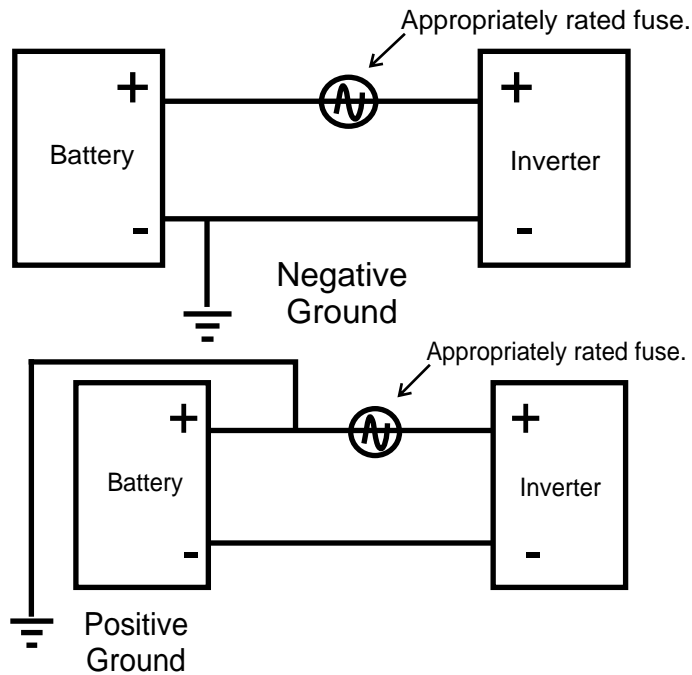
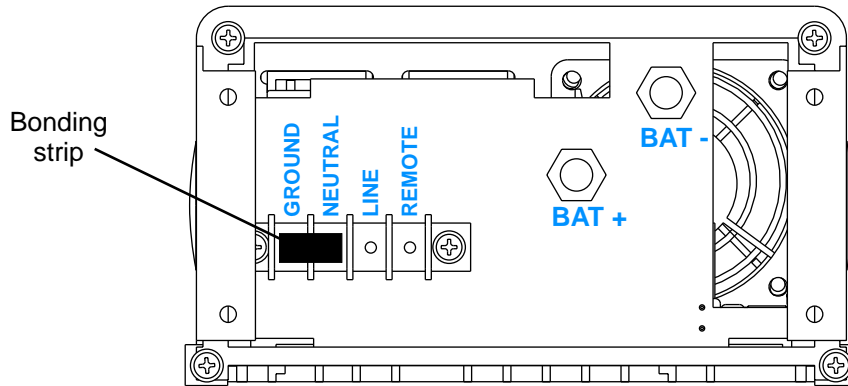

**XP-2000 Rear View with access cover removed
(AC/DC Connections):**

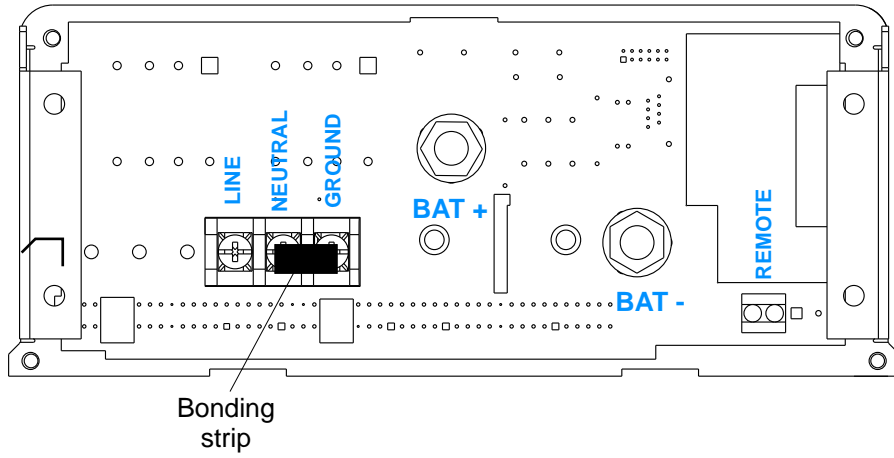

Made in the USA



*7317 Jack Newell Blvd. North
Fort Worth, Texas 76118-7100
817-595-4969 voice, 817-595-1290 fax
800-886-4683 toll free
website www.exeltech.com*