

Technical Note

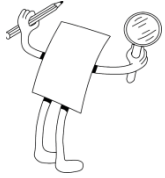

SolarEdge Fixed String Voltage, Concept of Operation

The SolarEdge system maintains a fixed string voltage regardless of string characteristics and environmental conditions. This application note details the concept of operation of the SolarEdge fixed string voltage and its benefits.

Concept of Operation

The SolarEdge power optimizer is a DC-DC power optimizer integrated into each module, replacing the junction box. The power optimizers, using an input control loop, perform per module MPPT and enable performance monitoring of each module. In an independent process, the power optimizers enable the inverter to automatically maintain a fixed string voltage, at the optimal point for DC-AC conversion by the inverter, regardless of string length and individual module performance.

The operating principles of the SolarEdge system are illustrated in the following example which examines a system's behavior under varying conditions.

The example system consists of 10 200W modules. Each module has a power optimizer connected to it, which is essentially a DC/DC buck-boost converter with an MPPT controller. The power optimizers are serially-connected to form a string; multiple strings can be connected in parallel to the same input of the SolarEdge inverter. The SolarEdge inverter is a single stage current source – it continuously adapts the current it draws from the PV array in order to keep the input voltage constant.

The SolarEdge power optimizer is highly efficient, maintaining over 98.8% weighted conversion efficiency over a wide range of conditions. However, for calculation simplicity, we assume 100% power optimizer efficiency in this example.

Scenario 1 – Ideal Conditions: Initially, we assume that all the modules are exposed to full irradiance with each providing 200W of power. The power output of each solar module is maintained at the module's maximum power point by an input control loop within the corresponding power optimizer. This MPP loop dictates to the power optimizer an input current I_{in} and input voltage V_{in} that ensures the transfer of the entire 200W from the module to the DC bus. We assume an MPP voltage for each module (given perfectly matched modules for demonstration purposes) of $V_{MPP} = 32V$. This means the input voltage to the power optimizer is 32V, and the input current is $200W/32V = 6.25A$. The input voltage to the inverter is controlled by a separate feedback loop. For simplicity, in this example the inverter requires a constant 350V. Since there are ten serially-connected modules, each providing 200W, the input current to the inverter is $2000W/350V = 5.7A$. Thus, the DC bus current flowing through each of the power optimizers must be 5.7A. This means that each power optimizer in this example provides an output voltage of $200W/5.7A = 35V$. In this case, the power optimizers are acting as up converters, converting the 32V input voltage to the target 35V output voltage.

The various system currents and voltages in this case are illustrated in Figure 1.

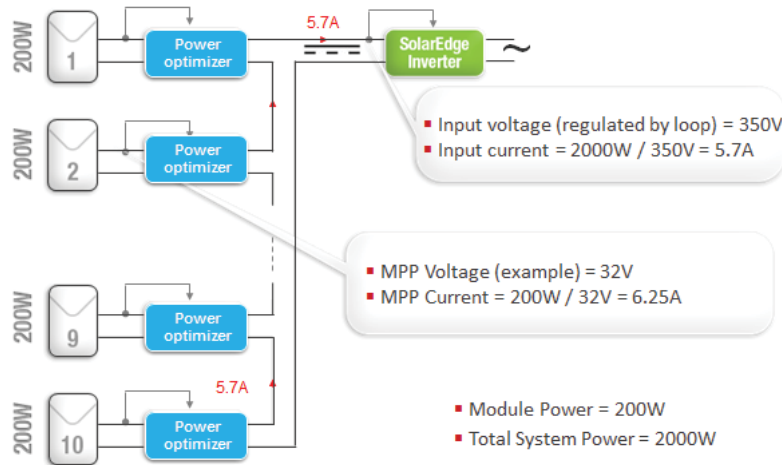

Figure 1: Operation under Ideal Conditions

Scenario 2 - Partial Shading: Next, we assume module #9 is shaded and consequently produces only 80W of power. The other modules are not shaded and each module still produces 200W of power. The power optimizer of the shaded module maintains its module at its maximum power point, which is now lowered due to the shading. Assuming $V_{MPP} = 28V$, the module current is $80W/28V = 2.86A$. The total power produced by the string is now $9*200W+80W = 1880W$. Since the inverter still needs to maintain an input voltage of 350V, the input current to the inverter will now be $1880W/350V = 5.37A$. This means that the DC bus current must be 5.37A. Therefore, the power optimizers of the 9 un-shaded modules will have an output voltage of $200W/5.37A = 37.2V$.

In contrast, the power optimizer attached to the shaded module will output $80W/5.37A = 14.9V$. The input to the inverter can be obtained by summing 9 modules providing 37.2V and 1 module providing 14.9V, adding up to 350V, as required by the inverter. In this scenario, the 9 power optimizers producing 200W INCREASE their output voltage, compared to the no-shading scenario, in order to compensate for the voltage drop of the shaded module.

The various system currents and voltages in this case are illustrated in Figure 2.

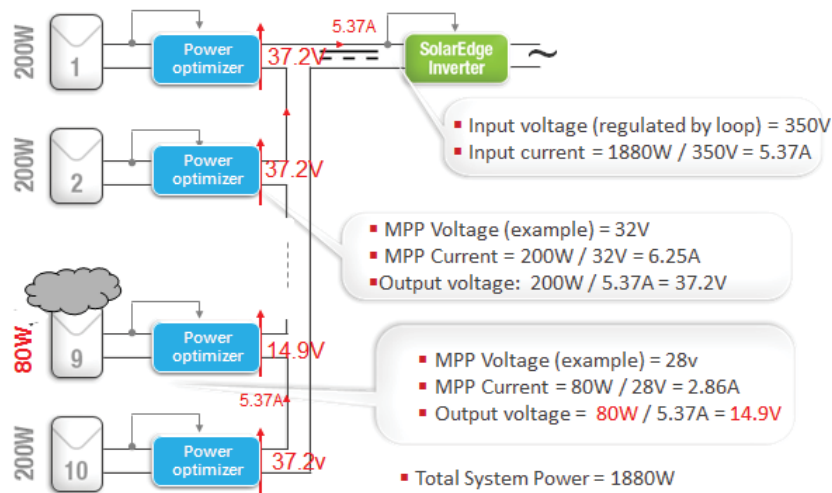

Figure 2: Operation with Partial Shading

As demonstrated by this example, each module operating at its maximum power point, regardless of operating conditions.

A comparison of the system operation in both scenarios can be seen in Figure 3. Note that both up and down DC/DC conversion are automatically used, depending on environmental conditions.

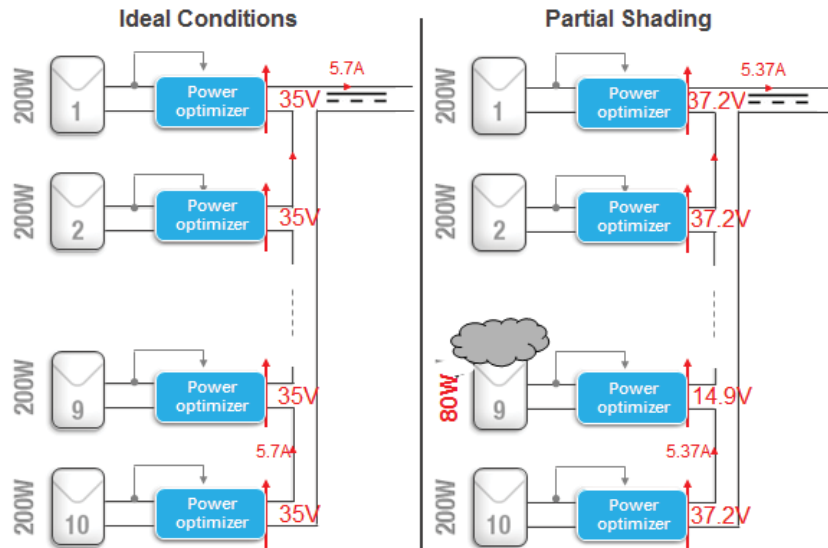

Figure 3: Scenario Comparison

Fixed String Voltage Benefits

The fixed string voltage maintained by SolarEdge power optimizers provide multiple benefits:

- **Flexible Design** – mismatched modules can be serially-connected in a string. The number of modules in a single string is not dependant on module output voltage and therefore a wide string length range is permitted¹.
- **High Inverter Efficiency and Reliability** – the SolarEdge inverter components work at a fixed voltage, operating under less stress. The inverter always operates at a voltage that enables optimal DC-AC inversion efficiency, independent of string length or environmental conditions.
- **Reduced Installation Cost** - longer strings, lower BoS element count and installation cost and labor.
- **Temperature Indifference** - the SolarEdge fixed string voltage completely removes the temperature constraints which strongly limit string length in traditional systems.
- **Improved Safety** - all power optimizers start up in "safety 1V output" mode until the power optimizers are connected to a functioning SolarEdge inverter. Additionally, in the event of a grid power shutdown, the modules immediately stop producing power and revert to this mode.

¹ For full string sizing calculations refer to "Application Note, SolarEdge String Sizing" on the SolarEdge website