

Series 100 Metal Roof Base

The Metal Roof Base (MRB) provides a robust, self-sealing mounting base for common corrugated metal roof profiles with a flat mounting surface. The base seals to the roof with an integral EPDM Rubber Washer and a sealing top cap. The completed assembly has a 5/16" stud compatible with existing SnapNrack components. The MRB can't be beat for ease of installation and reliability over the service life of the system.

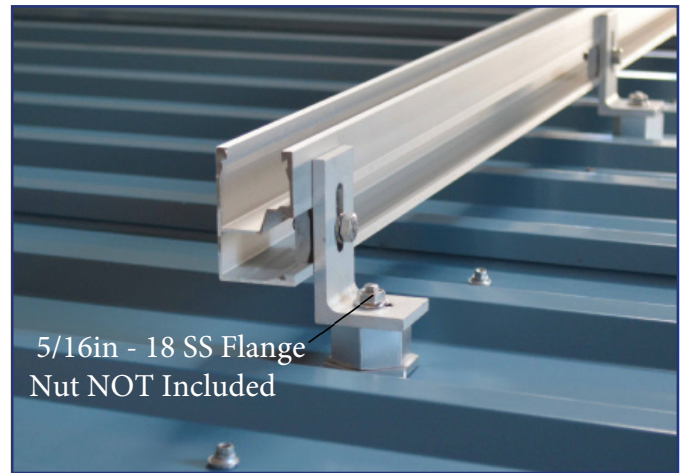

Features Include

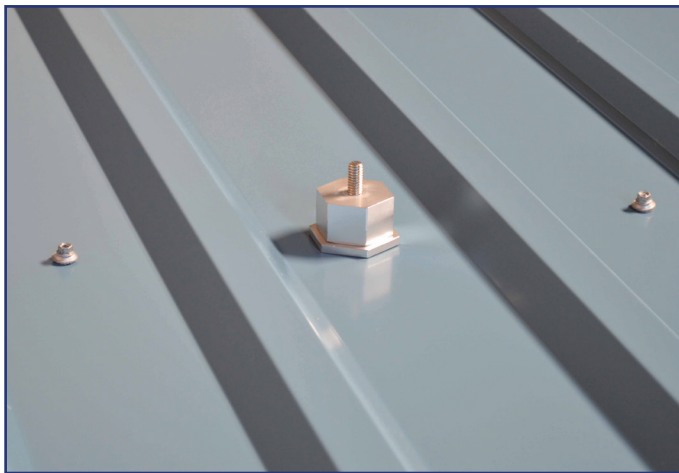
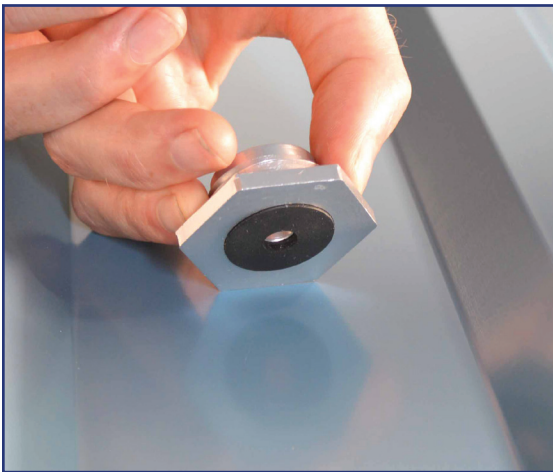

Single Tool
Installation



Preassembled
hardware



Integrated bonding



UL 2703 Certified

Metal Roof Base Assembly

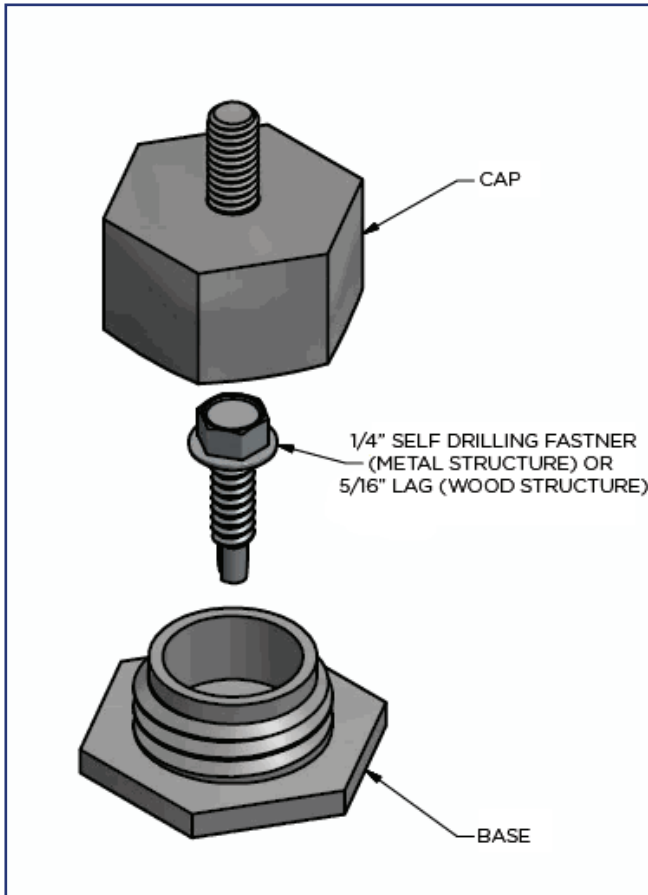

Metal Roof Base Dimensions

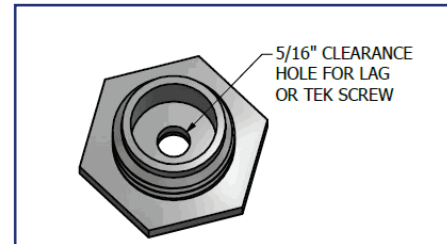
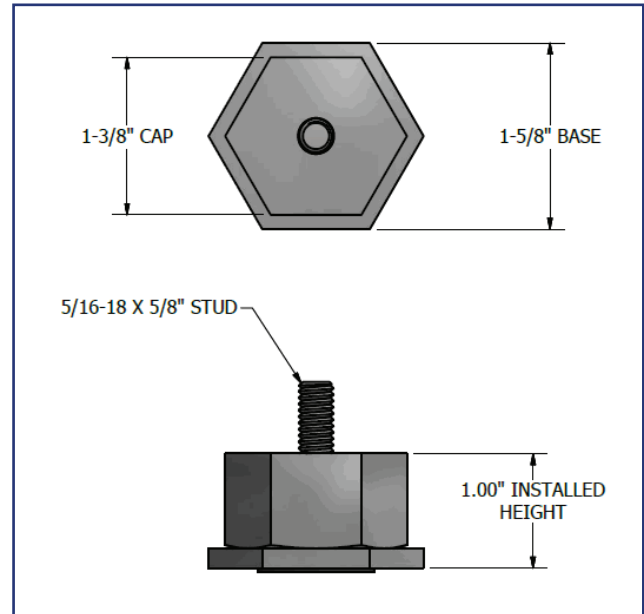

Self-Drilling screw or lag is not provided with assembly

***Attach the metal roof base to rafter with 5/16" X XX/X" SS lag bolt MIN 2-1/2" thread penetration into wood rafter. After the pilot hole for lag bolt has been drilled into the rafter, seal w/ Chemlink MI (OR EQUIV). (LOCALLY SOURCED LAG BOLT & 5/16in - 18 SS Flange Nut NOT INCLUDED)**

METAL ROOF BASE TECHNICAL DATA

Materials	<ul style="list-style-type: none"> • 6000 Series aluminum • Stainless steel stud • EPDM rubber seals
Material Finish	Clear anodized aluminum
Weight	0.4 lbs
Design Uplift Load	550 lbs uplift
Design Ultimate Load	1,000 lbs uplift
Warranty	10 year limited product warranty; 5 year limited finish warranty