

User Manual

**SUNNY BOY 3.0-US / 3.8-US / 5.0-US /
6.0-US / 7.0-US / 7.7-US**

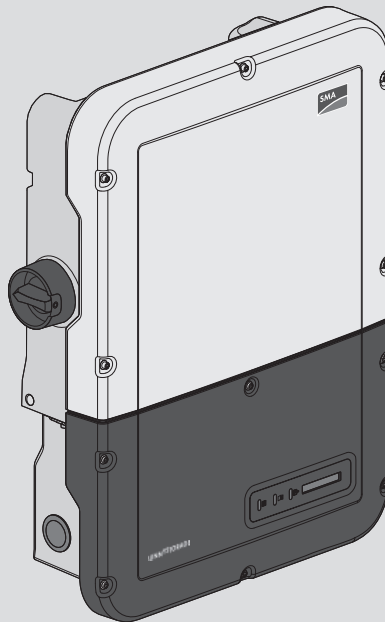

Legal Provisions

The information contained in these documents is the property of SMA Solar Technology AG. No part of this document may be reproduced, stored in a retrieval system, or transmitted, in any form or by any means, be it electronic, mechanical, photographic, magnetic or otherwise, without the prior written permission of SMA Solar Technology AG. Internal reproduction used solely for the purpose of product evaluation or other proper use is allowed and does not require prior approval.

SMA Solar Technology AG makes no representations or warranties, express or implied, with respect to this documentation or any of the equipment and/or software it may describe, including (with no limitation) any implied warranties of utility, merchantability, or fitness for any particular purpose. All such representations or warranties are expressly disclaimed. Neither SMA Solar Technology AG nor its distributors or dealers shall be liable for any indirect, incidental, or consequential damages under any circumstances.

The exclusion of implied warranties may not apply in all cases under some statutes, and thus the above exclusion may not apply.

Specifications are subject to change without notice. Every attempt has been made to make this document complete, accurate and up-to-date. Readers are cautioned, however, that product improvements and field usage experience may cause SMA Solar Technology AG to make changes to these specifications without advance notice, or per contract provisions in those cases where a supply agreement requires advance notice. SMA Solar Technology AG shall not be responsible for any damages, including indirect, incidental or consequential damages, caused by reliance on the material presented, including, but not limited to, omissions, typographical errors, arithmetical errors or listing errors in the content material.

SMA Warranty

You can download the current warranty conditions from the Internet at www.SMA-Solar.com.

Software licenses

The licenses for the used software modules can be called up on the user interface of the product.

Trademarks

All trademarks are recognized, even if not explicitly identified as such. Missing designations do not mean that a product or brand is not a registered trademark.

SMA Solar Technology AG

Sonnenallee 1

34266 Niestetal

Germany

Tel. +49 561 9522-0

Fax +49 561 9522-100

www.SMA.de

Email: info@SMA.de

Status: 2/5/2019

Copyright © 2019 SMA Solar Technology AG. All rights reserved.

Table of Contents

1	Information on this Document	5
1.1	Validity	5
1.2	Target Group.....	5
1.3	Content and Structure of this Document	5
1.4	Levels of warning messages	5
1.5	Symbols in the Document	6
1.6	Typographies in the document	6
1.7	Designation in the document.....	7
1.8	Additional Information	7
2	Safety	8
2.1	Intended Use	8
2.2	IMPORTANT SAFETY INSTRUCTIONS.....	9
3	Product Overview	13
3.1	Product Description	13
3.2	Symbols on the Product	14
3.3	Interfaces and Functions	15
3.4	LED Signals	20
3.5	Display messages.....	21
4	Operation	22
4.1	Activating and Operating the Display.....	22
4.2	Establishing a connection to the user interface	22
4.2.1	Establishing a Direct Connection via Ethernet	22
4.2.2	Establishing a direct connection via WLAN	23
4.2.3	Establishing a Connection via Ethernet in the local network	24
4.2.4	Establishing a Connection via WLAN in the Local Network	25
4.3	Logging In and Out of the User Interface.....	26
4.4	Start Page Design of the User Interface.....	28
4.5	Displaying and Downloading the Stored Data.....	30
4.6	Activating the Smart Inverter Screen.....	31
4.7	Starting the Installation Assistant	31
4.8	Secure Power Supply Operation	33
4.8.1	Activating Secure Power Supply Operation	33
4.8.2	Deactivating Secure Power Supply Operation.....	34
4.9	Activate WPS Function.....	34
4.10	Switching WLAN On and Off.....	35
4.11	Switching the Dynamic Power Display Off.....	36

4.12	Changing the Password.....	36
4.13	Changing Operating Parameters.....	37
4.14	Configuring the Country Data Set.....	38
4.15	Activating of the Rapid Shutdown DC discharge function	38
4.16	Changing the Operating Mode of the Multifunction Relay	38
4.17	Configuring the Modbus Function.....	39
4.18	Setting SMA OptiTrac Global Peak	40
4.19	Deactivating the Arc-Fault Circuit Interrupter (AFCI).....	40
4.20	Saving the Configuration in a File.....	41
4.21	Adopting a Configuration from a File.....	41
4.22	Updating the Firmware	42
5	Cleaning the Inverter	44
6	Troubleshooting.....	45
6.1	Forgotten Password.....	45
6.2	Event Messages	46
6.3	Checking the PV System for Ground Faults.....	64
6.4	Resetting the Operation Inhibition after Detection of an Arc Fault	68
7	Accessories	70
8	Compliance Information	71
9	Contact	72

1 Information on this Document

1.1 Validity

This document is valid for:

- SB3.0-1TP-US-40 (Sunny Boy 3.0-US) from firmware version $\geq 2.04.88.R$
- SB3.8-1TP-US-40 (Sunny Boy 3.8-US) from firmware version $\geq 2.04.88.R$
- SB5.0-1TP-US-40 (Sunny Boy 5.0-US) from firmware version $\geq 2.04.88.R$
- SB6.0-1TP-US-40 (Sunny Boy 6.0-US) from firmware version $\geq 2.04.88.R$
- SB7.0-1TP-US-40 (Sunny Boy 7.0-US) from firmware version $\geq 2.04.88.R$
- SB7.7-1TP-US-40 (Sunny Boy 7.7-US) from firmware version $\geq 2.04.88.R$
- SB3.0-1SP-US-40 (Sunny Boy 3.0-US) from firmware version $\geq 2.04.88.R$
- SB3.8-1SP-US-40 (Sunny Boy 3.8-US) from firmware version $\geq 2.04.88.R$
- SB5.0-1SP-US-40 (Sunny Boy 5.0-US) from firmware version $\geq 2.04.88.R$
- SB6.0-1SP-US-40 (Sunny Boy 6.0-US) from firmware version $\geq 2.04.88.R$
- SB7.0-1SP-US-40 (Sunny Boy 7.0-US) from firmware version $\geq 2.04.88.R$
- SB7.7-1SP-US-40 (Sunny Boy 7.7-US) from firmware version $\geq 2.04.88.R$

1.2 Target Group

This document is intended for qualified persons and end users. Only qualified persons are allowed to perform the activities marked in this document with a warning symbol and the caption "Qualified person". Tasks that do not require any particular qualification are not marked and can also be performed by end users. Qualified persons must have the following skills:

- Knowledge of how an inverter works and is operated
- Training in how to deal with the dangers and risks associated with installing, repairing and using electrical devices and installations
- Training in the installation and commissioning of electrical devices and installations
- Knowledge of all applicable laws, standards and directives
- Knowledge of and compliance with this document and all safety information

1.3 Content and Structure of this Document

This document describes the configuration, operation and troubleshooting of the product as well as the operation of the product user interface.

You will find the latest version of this document and further information on the product in PDF format at www.SMA-Solar.com.

Illustrations in this document are reduced to the essential information and may deviate from the real product.

1.4 Levels of warning messages

The following levels of warning messages may occur when handling the product.

⚠ DANGER

Indicates a hazardous situation which, if not avoided, will result in death or serious injury.

⚠ WARNING

Indicates a hazardous situation which, if not avoided, could result in death or serious injury.



⚠ CAUTION

Indicates a hazardous situation which, if not avoided, could result in minor or moderate injury.

NOTICE

Indicates a situation which, if not avoided, can result in property damage.

1.5 Symbols in the Document

Symbol	Explanation
	Information that is important for a specific topic or goal, but is not safety-relevant
<input type="checkbox"/>	Indicates a requirement for meeting a specific goal
<input checked="" type="checkbox"/>	Desired result
x	A problem that might occur
	Example

1.6 Typographies in the document

Typography	Use	Example
bold	<ul style="list-style-type: none"> Messages Terminals Elements on a user interface Elements to be selected Elements to be entered 	<ul style="list-style-type: none"> Connect the insulated conductors to the terminals X703:1 to X703:6. Enter 10 in the field Minutes.
>	<ul style="list-style-type: none"> Connects several elements to be selected 	<ul style="list-style-type: none"> Select Settings > Date.
[Button] [Key]	<ul style="list-style-type: none"> Button or key to be selected or pressed 	<ul style="list-style-type: none"> Select [Enter].

1.7 Designation in the document

Complete designation	Designation in this document
Sunny Boy	Inverter, product

1.8 Additional Information

For more information, please go to www.SMA-Solar.com.

Title and information content	Type of information
Mounting, installation, commissioning and decommissioning	Installation manual
"Application for SMA Grid Guard Code"	Form
"PUBLIC CYBER SECURITY - Guidelines for a Secure PV System Communication"	Technical information
"Efficiency and Derating" Efficiency and derating behavior of the SMA inverters	Technical Information
"Grid Support Utility Interactive Inverters" Information about how to activate and to set the grid supporting features according to UL 1741 SA	Technical Information
"Parameters and Measured Values" Overview of all inverter operating parameters and their configuration options	Technical Information
"SMA and SunSpec Modbus® Interface" Information on the Modbus interface	Technical Information
"Modbus® parameters and measured values" Device-specific register HTML file	Technical Information
"SMA Modbus® Interface" Information on the commissioning and configuration of the SMA Modbus interface	Technical Information

2 Safety

2.1 Intended Use

The Sunny Boy is a transformerless PV inverter which converts the direct current of the PV array to grid-compliant alternating current and feeds it into the utility grid.

The product is suitable for indoor and outdoor use.

The product must only be operated with PV arrays (PV modules and cabling) that are approved by the electrical standards applicable on-site and the *National Electrical Code*® ANSI/NFPA 70 or the *Canadian Electrical Code*® CSA C22.1.

i No galvanic isolation

The product is not equipped with a transformer and therefore has no galvanic isolation.

- Do not operate grounded PV modules together with the product. If grounded PV modules are connected to the product, an event will occur which will appear on the product display. The event will also be displayed, along with the associated message, in the event list on the user interface of the product.
- Only ground the mounting frames of the PV modules.
- The neutral conductor of the AC output is not bonded to ground within the product.
- The neutral conductor of the AC output for secure power supply operation is bonded to ground within the product.

PV modules with a high capacity to ground may only be used if their coupling capacity does not exceed 2.5 μF .

To protect the PV system against excessive reverse currents under fault conditions, a DC-side overcurrent protective device must be connected in accordance with the *National Electrical Code*® to prevent any short-circuit currents that exceed the ampacity of the DC electric circuit or the maximum series fuse rating of the PV modules. Typically, this requires string fusing where more than two strings are combined in parallel. Where an overcurrent protection device is required, the *National Electrical Code*® requires that both positive and negative conductors have overcurrent protection for ungrounded PV modules.

All components must remain within their permitted operating ranges and their installation requirements at all times.

The product is approved for the US and Canadian market.

Use this product only in accordance with the information provided in the enclosed documentation and with the locally applicable laws, regulations, standards and directives. Any other application may cause personal injury or property damage.

Alterations to the product, e.g. changes or modifications, are only permitted with the express written permission of SMA Solar Technology AG. Unauthorized alterations will void guarantee and warranty claims and in most cases terminate the operating license. SMA Solar Technology AG shall not be held liable for any damage caused by such changes.

Any use of the product other than that described in the Intended Use section does not qualify as the intended use.

The enclosed documentation is an integral part of this product. Keep the documentation in a convenient, dry place for future reference and observe all instructions contained therein.

This document does not replace and is not intended to replace any local, state, provincial, federal or national laws, regulations or codes applicable to the installation, electrical safety and use of the product. SMA Solar Technology AG assumes no responsibility for the compliance or non-compliance with such laws or codes in connection with the installation of the product.

The type label must remain permanently attached to the product.

2.2 IMPORTANT SAFETY INSTRUCTIONS

SAVE THESE INSTRUCTIONS

This section contains safety information that must be observed at all times when working on or with the product.

The product has been designed and tested in accordance with international safety requirements. As with all electrical or electronic devices, there are residual risks despite careful construction. To prevent personal injury and property damage and to ensure long-term operation of the product, read this section carefully and observe all safety information at all times.

DANGER

Danger to life due to electric shock when live components or DC conductors are touched

When exposed to sunlight, the PV modules generate high DC voltage which is present in the DC conductors. Touching live DC conductors results in death or lethal injuries due to electric shock.

- Disconnect the product from voltage sources and make sure it cannot be reconnected before working on the device.
- Do not touch non-insulated parts or cables.
- Do not remove the terminal block with the connected DC conductors from the slot under load.
- Wear suitable personal protective equipment for all work on the product.

⚠ DANGER**Danger to life due to electric shock when touching live system components in case of a ground fault**

If a ground fault occurs, parts of the system may still be live. Touching live parts and cables results in death or lethal injuries due to electric shock.

- Disconnect the product from voltage sources and make sure it cannot be reconnected before working on the device.
- Touch the cables of the PV array on the insulation only.
- Do not touch any parts of the substructure or frame of the PV array.
- Do not connect PV strings with ground faults to the inverter.
- Ensure that no voltage is present and wait five minutes before touching any parts of the PV system or the product.

⚠ DANGER**Danger to life due to electric shock in case of overvoltages and if surge protection is missing**

Overvoltages (e. g. in the event of a flash of lightning) can be further conducted into the building and to other connected devices in the same network via the network cables or other data cables if there is no surge protection. Touching live parts and cables results in death or lethal injuries due to electric shock.

- Ensure that all devices in the same network are integrated in the existing overvoltage protection.
- When laying the network cable outdoors, ensure that there is suitable surge protection at the network cable transition from the product outdoors to the network inside the building.
- The Ethernet interface of the inverter is classified as "TNV-1" and offers protection against overvoltages of up to 1.5 kV.

⚠ WARNING**Danger to life due to fire or explosion**

Despite careful construction, a fire or explosion may occur in electrical devices. Death or lethal injuries due to fire or flying debris can result.

- Wear suitable personal protective equipment for all work on the product.
- Do not mount the product in areas containing highly flammable materials or gases.
- Do not mount the product in potentially explosive atmospheres.
- Ensure that unauthorized persons have no access to the product.
- In case of error, only carry out corrective measures specified by SMA Solar Technology AG (see Section 6 "Troubleshooting", page 45). If no corrective measures are specified, do not perform any actions on the product. Contact the Service.

⚠ CAUTION**Risk of burns from hot surfaces**

The surface of the inverter can get very hot. Touching the surface can result in burns.

- Mount the inverter in such a way that it cannot be touched inadvertently.
- Do not touch hot surfaces.
- Wait 30 minutes for the surface to cool sufficiently.
- Observe the safety messages on the inverter.

⚠ CAUTION**Risk of injury due to weight of product**

Injuries may result if the product is lifted incorrectly or dropped while being transported or when attaching it to or removing it from the wall mounting bracket.

- Transport and lift the product carefully. Take the weight of the product into account.
- Wear suitable personal protective equipment for all work on the product.

NOTICE**Damage to the enclosure seal in subfreezing conditions**

If you open the product or disconnect the Power Unit and Connection Unit when temperatures are below freezing, the enclosure seals can be damaged. Moisture can penetrate the product and damage it.

- If a layer of ice has formed on the enclosure seal when temperatures are below freezing, remove it prior to opening the product (e.g. by melting the ice with warm air). Observe the applicable safety regulations.
- Do not disassemble the Power Unit and Connection Unit unless the ambient temperature is at least 0°C (32°F) and conditions are frost-free.

NOTICE**Damage to the product due to sand, dust and moisture ingress**

Sand, dust and moisture penetration can damage the product and impair its functionality.

- Only open the product if the humidity is within the thresholds and the environment is free of sand and dust.
- Do not open the product during a dust storm or precipitation.
- Close tightly all enclosure openings.
- Only use listed rain-tight or liquid-tight conduit fittings to attach the conduits to the product.

NOTICE**Damage due to cleaning agents**

The use of cleaning agents may cause damage to the product and its components.

- Clean the product and all its components only with a cloth moistened with clear water.

NOTICE**Damage to the inverter due to electrostatic discharge**

Touching electronic components can cause damage to or destroy the inverter through electrostatic discharge.

- Ground yourself before touching any component.

NOTICE**Destruction of the measuring device due to overvoltage**

- Only use measuring devices with a DC input voltage range of 600 V or higher.

i Electrical installations (for North America)

All installations must conform with the laws, regulations, codes and standards applicable in the jurisdiction of installation (e.g. *National Electrical Code*® ANSI/NFPA 70 or *Canadian Electrical Code*® CSA-C22.1.).

- Before connecting the product to the utility grid, contact your local grid operator. The electrical connection of the product must be carried out by qualified persons only.
- Ensure that the cables or conductors used for electrical connection are not damaged.

3 Product Overview

3.1 Product Description

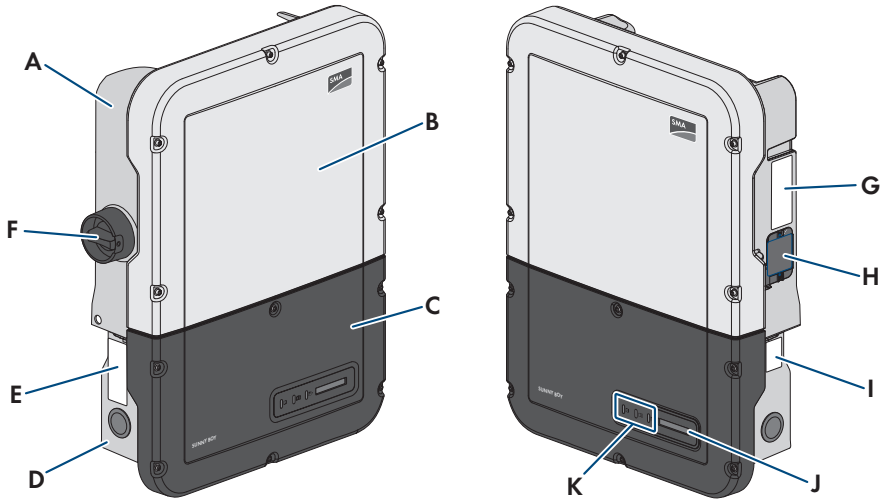









Figure 1: Design of the inverter

Position	Designation
A	Power Unit
B	Enclosure lid of the Power Unit
C	Enclosure lid for the Connection Unit
D	Connection Unit
E	Warning label with compliance information
F	DC load-break switch
G	Type label The type label clearly identifies the product. The type label must remain permanently attached to the product. You will find the following information on the type label: <ul style="list-style-type: none"> • Device type (Model) • Serial number (Serial No. or S/N) • Date of manufacture • Identification key (PIC) for registration in Sunny Portal • Registration ID (RID) for registration in Sunny Portal • WLAN password (WPA2-PSK) for the direct connection to the user interface of the inverter via WLAN • Device-specific characteristics

Position	Designation
H	Fan (only with Sunny Boy 7.0 and 7.7)
I	<p>Additional type label</p> <p>The additional type label must remain permanently attached to the product. You will find the following information on the additional type label:</p> <ul style="list-style-type: none"> • Identification key (PIC) for registration in Sunny Portal • Registration ID (RID) for registration in Sunny Portal • WLAN password (WPA2-PSK) for the direct connection to the user interface of the inverter via WLAN
J	<p>Display</p> <p>The display shows the current operating data and events or errors.</p>
K	<p>LEDs</p> <p>The LEDs indicate the operating state of the inverter.</p>

3.2 Symbols on the Product

Symbol	Explanation
	<p>Beware of electrical voltage</p> <p>The product operates at high voltages.</p>
	<p>Beware of hot surface</p> <p>The product can get hot during operation.</p>
	<p>Observe the documentation</p> <p>Observe all documentation supplied with the product.</p>
	<p>Observe the documentation</p> <p>Together with the red LED, this symbol indicates an error.</p>
	<p>Inverter</p> <p>Together with the green LED, this symbol indicates the operating state of the inverter.</p>
	<p>Data transmission</p> <p>Together with the blue LED, this symbol indicates the status of the network connection.</p>

Symbol	Explanation
	Equipment Grounding Terminal This symbol indicates the position for the connection of an equipment grounding conductor.
	UL 1741 and CSA C22.2 No. 107.1 are the standards applied by Underwriters Laboratories to the product to certify that it meets the requirements of the <i>National Electrical Code</i> [®] , the <i>Canadian Electrical Code</i> [®] and IEEE 1547.

3.3 Interfaces and Functions

The inverter can be equipped or retrofitted with the following interfaces and functions:

User interface for monitoring and configuration

The product is equipped as standard with an integrated webserver, which provides a user interface for configuring and monitoring the product. The product user interface can be called up via the web browser if there is an existing connection to an end device (e.g. computer, tablet PC or smartphone).

SMA Speedwire

The product is equipped with SMA Speedwire as standard. SMA Speedwire is a type of communication based on the Ethernet standard. SMA Speedwire is designed for a data transfer rate of 100 Mbps and enables optimum communication between Speedwire devices within systems.

Class 1 wiring methods are to be used for field wiring connection to the terminals of the communication interface.

SMA Webconnect

The inverter is equipped with a Webconnect function as standard. The Webconnect function enables direct data transmission between the inverter and Sunny Portal (online monitoring system from SMA).

There are two Sunny Portal versions: the classical Sunny Portal (<https://www.sunnyportal.com>) and the newly developed Sunny Portal powered by ennexOS (<https://ennexOS.sunnyportal.com>). Both systems differ in their supported functions. With an existing user account, you can log into both portals as well as into Sunny Design (system planning software from SMA).

In a Sunny Portal system, up to four inverters with Webconnect function can be displayed together. A communication product (e.g. SMA Data Manager) is required for systems with more than four inverters.

The system must be registered in the classic Sunny Portal if the inverter is integrated into a local network and connected to the Internet via this network. With this connection, you have the possibility to view the data online in real time.

If the inverter is connected to the Internet via the cellular network, you must register the system in Sunny Portal powered by ennexOS. The communication with the inverters is optimized with regard to the data volume and availability of the inverter. No data can be viewed in real time. Note that the inverter must be equipped with a firmware version $\geq 2.04.88.R$ for connection via the cellular network.

WLAN

The product is equipped with a WLAN interface as standard. The inverter is delivered with the WLAN interface activated as standard. If you do not want to use WLAN, you can deactivate the WLAN interface.

In addition, the product has a WPS function. The WPS function is for automatically connecting the product to a network (e.g. via router) and establish a direct connection between the product and an end device.

Expanding the radio range in the WLAN network

In order to expand the radio range of the inverter in the WLAN network, you can install the Antenna Extension Kit accessory set in the inverter.

Modbus

The product is equipped with a Modbus interface. The Modbus interface is deactivated by default and must be configured as needed.

The Modbus interface of the supported SMA products is designed for industrial use – via SCADA systems, for example – and has the following tasks:

- Remote query of measured values
- Remote setting of operating parameters
- Setpoint specifications for system control

Module slots

The inverter is standard-equipped with two module slots. The module slots are located on the communication assembly and allow additional modules to be connected (e.g. SMA Sensor Module). The modules are available as accessories. The installation of two identical modules is not permissible.

SMA RS485 Module

The inverters of type "SBx.x-1SP-US-40" can be retrofitted with the SMA RS485 Module.

By installing the SMA RS485 Module, the inverter is able to communicate with the energy meter of the SMA Revenue Grade Meter Kit.

Class 1 wiring methods are to be used for field wiring connection to the terminals of the communication interface.

Antenna Extension Kit

Within the WLAN network, the Antenna Extension Kit enables the radio range of the inverter to be upgraded (Information on assembly and connection see manual of the Antenna Extension Kit). The Antenna Extension Kit can be retrofitted.

SMA Sensor Module

The SMA Sensor Module has different interfaces for connecting various sensors (i.e. temperature sensor, irradiation sensor, anemometer or energy meter). The SMA Sensor Module converts the signals of the connected sensors and transmits them to the inverter. The SMA Sensor Module can be retrofitted.

SMA Cellular LTE Modem Kit

The inverter type "SBx.x-1SP-US-40" can be retrofitted with the SMA Cellular LTE Modem Kit. The inverter type "SBx.x-1TP-US-40" is equipped with SMA Cellular LTE Modem Kit as standard.

The SMA Cellular LTE Modem Kit allows the direct data transmission between the inverter and the internet portal Sunny Portal via the cellular network as an alternative to data transmission via Ethernet or WLAN. In addition, the SMA Cellular LTE Modem Kit enables the communication between the inverter and the energy meter.

The SMA Cellular LTE Modem Kit transmits up to four times a day a limited amount of data to Sunny Portal. The standard term of the mobile data plan for the SMA Cellular LTE Modem Kit is five years. All costs are covered within the term. No additional costs will be incurred. You have the possibility to extend the term of the mobile data plan. For this purpose, contact SMA Solar Technology AG. By using the SMA Cellular LTE Modem Kits, a local network connection is not absolutely necessary. However, it is recommended to be able to view all information regarding the system in Sunny Portal.

Energy meters in accordance with ANSI C12.20

The inverter type "SBx.x-1SP-US-40" can be retrofitted with the SMA Revenue Grade Meter Kit that in accordance with ANSI C12.20 includes an energy meter. The inverter must be equipped either with the SMA Cellular LTE Modem Kit or SMA RS485 Module to operate the SMA Revenue Grade Meter Kit. The inverter type "SBx.x-1TP-US-40" is equipped with an energy meter as standard.

The energy meter fulfills the accuracy class 0.5 in accordance with ANSI C12.20. The energy meter is a so called PV production meter intended to measure the generated energy of the inverter. The measured values of the energy meter can be used for billing purposes.

Grid Management Services

The inverter is a grid support interactive inverter.

The inverter was tested in accordance with the UL 1741 SA (2016-09-07) to be compliant with the source requirements documents of the states available at the time. For connecting the inverter to the utility grid, no additional grid monitoring equipment is necessary. A description of the tested functions and instructions on the activation and setting of functions can be found in the technical information "Grid Support Utility Interactive Inverters" at www.SMA-Solar.com.

PV Rapid Shutdown System Equipment

The inverter is a PV Rapid Shutdown System Equipment and performs the function of voltage reduction according to UL 1741 CRD PV Rapid Shutdown Systems 2015. When a rapid shutdown is triggered by disconnecting the utility grid, the inverter discharges independently on the AC side to ≤ 30 V within 30 seconds.

If a disconnection device is used in addition between the inverter and the PV array that disconnects the PV array in the case of a rapid shutdown, the inverter discharges independently on the DC side to ≤ 30 V within 30 seconds.

The electric discharge on the DC side is deactivated by default and must be activated manually after commissioning of the inverter via the user interface.

NOTICE - The inverter's Rapid Shutdown function is initiated by disconnecting the inverter from the AC grid voltage, for example, by opening the main PV system AC disconnect. The AC disconnect that serves as the Rapid Shutdown initiation device must be readily accessible and clearly marked in accordance with National Electrical Code®. The Rapid Shutdown status of the PV system will be indicated by the On/Off (Closed/Open) position of this AC disconnect. The Off (Open) position indicates that Rapid Shutdown has been initiated.

Parallel Operation of the DC Inputs A and B

The DC inputs A and B of the inverter can be operated in parallel and up to three strings can be connected to it in parallel. As a result, as opposed to normal operation, up to three strings can be connected directly to inverters with two DC inputs and up to four strings to inverters with three DC inputs. The inverter automatically detects the parallel operation of the DC inputs A and B.

Secure power supply operation

You can connect an external outlet and a switch to the inverter in order to activate the outlet. In case of a grid failure, the outlet supplies a load with current from the PV system. When the outlet is activated via the switch, the load is supplied with current from the PV system. The inverter automatically regulates the energy supply of the outlet depending on the solar irradiation on the PV system. When the outlet is activated and a load is supplied with current from the PV system, the inverter is disconnected from the utility grid and does not feed into the utility grid.

If the available accessory communication set for TS4-R module technology components (SMA Rooftop Communication Kit) is installed in the inverter, the secure power supply operation is no longer available. The Rooftop Communication Kit supports the Rapid Shutdown function. The AC circuit breaker in the system is simultaneously the Rapid Shutdown initiator. In the event of a grid failure or when operating the Rapid Shutdown initiator, the inverter is also disconnected from voltage sources on the DC side. Thus the supply of the outlet for secure power supply operation can no longer be guaranteed.

i Do not connect loads that require a stable electricity supply to the outlet for secure power supply operation

Secure power supply operation must not be used for loads that require a stable electricity supply. The power available during secure power supply operation depends on the solar irradiation on the PV system. Therefore, power output can fluctuate considerably depending on the weather or may not be available at all.

- Do not connect loads to the outlet for secure power supply operation if they are dependent on a stable electricity supply for reliable operation.

Multifunction Relay

The inverter is equipped with a multifunction relay as standard. The multifunction relay is an interface that can be configured for the operating mode used by a particular system.

String-failure detection

The self-learning string failure detection identifies to which of the three inverter DC inputs the strings are connected. The self-learning string failure detection identifies if the connected string is inoperable and is no longer contributing to the energy yield (e.g. due to damages such as a cable break) and monitors the input to which the defective string is connected. If the error persists, an event will be reported at the latest one day after the detection of the defective string. This prevents partial failures of the PV array from being undetected for a long time and which will result in yield losses. The self-learning string failure detections automatically identifies if a string has been repaired and resets the event. If the defective string should no longer be connected, the event must be reset manually.

Arc-Fault Circuit Interrupter (AFCI)

In accordance with the *National Electrical Code*[®], the inverter has a system for DC arc fault detection and interruption. The arc-fault circuit interrupter is listed in accordance with UL 1699B Ed. 1. A detected electric arc causes the inverter to interrupt feed-in operation: In order to restart feed-in operation, the feed-in operation must be activated manually. If the installation conditions allow it, you can deactivate the arc-fault circuit interrupter.

SMA Smart Connected

SMA Smart Connected is the free monitoring of the inverter via the SMA Sunny Portal. Thanks to SMA Smart Connected, the PV system operator and qualified person will be informed automatically and proactively about inverter events that occur.

SMA Smart Connected is activated during registration in Sunny Portal. In order to use SMA Smart Connected, it is necessary that the inverter is permanently connected to Sunny Portal and the data of the PV system operator and qualified person is stored in Sunny Portal and up-to-date.

3.4 LED Signals

The LEDs indicate the operating state of the inverter.

LED signal	Explanation
The green LED is flashing (two seconds on and two seconds off)	Waiting for feed-in conditions The conditions for feed-in operation are not yet met. As soon as the conditions are met, the inverter will start feed-in operation.
The green LED is flashing: 1.5 s on and 0.5 s off	Secure power supply operation The secure power supply operation is activated and the inverter supplies the outlet with current from the PV system.
The green LED flashes quickly	Update of central processing unit The central processing unit of the inverter is being updated.
The green LED is glowing	Feed-in operation The inverter feeds in with a power of at least 90%.
The green LED is pulsing	Feed-in operation The inverter is equipped with a dynamic power display via the green LED. Depending on the power, the green LED pulses fast or slow. If necessary, you can switch off the dynamic power display via the green LED.
The green LED is off	The inverter is not feeding into the utility grid.
The red LED is glowing	Event occurred In addition to the glowing red LED, the display indicates the following information about the event: <ul style="list-style-type: none"> • Event type • Event number • Date and time at which the event occurred
The blue LED flashes slowly for approx. one minute	Communication connection is being established The inverter is establishing a connection to a local network or is establishing a direct connection to an end device via Ethernet (e.g. computer, tablet PC or smartphone).
The blue LED flashes quickly for approx. two minutes.	WPS active The WPS function is active.
The blue LED is glowing	Communication active There is an active connection with a local network or there is a direct connection with an end device via Ethernet (e.g. computer, tablet PC or smartphone).

3.5 Display messages

Display message	Explanation
Package	Installed firmware version and configured country data set
Ser	Product serial number
HW	Hardware version of the product
FW-HP	Firmware version of the central processing unit
FW-KP	Firmware version of the communication processor
Ethcom A	Status of the network port A
Ethcom B	Status of the network port B
E-IP	Ethernet IP address of the product
SMsk	Subnet mask of the product
GW	Gateway address of the product
DNS	IP address of the domain name server
Wlancom	Status of the WLAN connection
W-IP	WLAN IP address of the product
DC A	Status of the DC input A
DC B	Status of the DC input B
DC C	Status of the DC input C
AC12	Voltage / current between the line conductors L1 and L2
AC13	Voltage / current between the line conductors L1 and L3
AC23	Voltage / current between the line conductors L2 and L3
SPS-mode active	The secure power supply operation is active.
P: Overload	Overload at the input for secure power supply operation
Update status	Firmware update information
Error	An event has occurred.
P	Instantaneous output power
E-Total	Total produced energy
Pmax	Maximum output power
cos phi	Displacement power factor
Update File(s) found	New firmware version available
Update progress	Update is being performed

4 Operation

4.1 Activating and Operating the Display

You can activate and operate the display by tapping on the enclosure lid of the Connection Unit.

Procedure:

1. Activate the display. Tap on the enclosure lid of the Connection Unit once.
 - The backlight is switched on.
2. To move to the next message, tap on the enclosure lid of the Connection Unit once.

4.2 Establishing a connection to the user interface

4.2.1 Establishing a Direct Connection via Ethernet

Requirements:

- The product must be commissioned.
- An end device (e.g. computer) with an Ethernet interface must be available.
- The product must be connected directly to the end device.
- The respective latest version of one of the following web browsers must be installed: Chrome, Edge, Firefox, Internet Explorer or Safari.
- The SMA Grid Guard code of the Installer must be available for the changing of grid-relevant settings after completion of the first ten feed-in hours or installation assistant (see "Application for SMA Grid Guard Code" at www.SMA-Solar.com).

Procedure:

1. Tap on the enclosure lid of the Connection Unit and continue to switch up to the message **E-IP: 169.254.xxx.xxx**.
 2. Read off the displayed IP address for the direct connection via Ethernet and either remember it or write it down.
 3. Open the web browser of your device, enter the IP address in the address line of the web browser and press the enter key.
 4.  **Web browser signals a security vulnerability**
 After the IP address has been confirmed by pressing the enter key, a message might appear indicating that the connection to the user interface of the inverter is not secure. SMA Solar Technology AG guarantees that calling up the user interface is secure.
 - Continue loading the user interface.
- The login page of the user interface opens.

4.2.2 Establishing a direct connection via WLAN

Requirements:

- The product must be commissioned.
- An end device (e.g. computer, tablet PC or smartphone) must be available.
- The respective latest version of one of the following web browsers must be installed: Chrome, Edge, Firefox, Internet Explorer or Safari.
- JavaScript must be enabled in the web browser of the end device.
- The SMA Grid Guard code of the Installer must be available for the changing of grid-relevant settings after completion of the first ten feed-in hours or installation assistant (see "Application for SMA Grid Guard Code" at www.SMA-Solar.com).

i SSID, IP address and necessary passwords

- SSID in WLAN: SMA[serial number] (e.g. SMA0123456789)
- Standard WLAN password (usable until completion of the configuration by means of the installation assistant or prior to the end of the first ten feed-in hours): SMA12345
- Device-specific WLAN password (usable for initial configuration to completion of the first ten feed-in hours): see WPA2-PSK on the type label of the inverter or on the back of the manual included in the delivery
- Standard IP address for a direct connection via WLAN outside of a local network: 192.168.12.3

i Importing and exporting files with end devices having an iOS operating system is not possible.

For technical reasons, importing and exporting files (e.g. importing an inverter configuration, saving the current inverter configuration or exporting events and parameters) is not possible with mobile end devices having an iOS operating system.

- Use an end device that does not have an iOS operating system for importing and exporting files.

The procedure can be different depending on the end devices. If the procedure described does not apply to your end device, establish the direct connection via WLAN as described in the manual of your end device.

Procedure:

1. If your end device has a WPS function:
 - Activate the WPS function on the inverter. To do this, tap twice on the enclosure lid of the Connection Unit.
 - The blue LED flashes quickly for approx. two minutes. The WPS function is active during this time.
 - Activate the WPS on your end device.
 - The connection with your end device will be established automatically. It can take up to 20 seconds for this connection to be established.
2. If your end device has not a WPS function:

- Search for WLAN networks with your end device.
 - Select the SSID of the inverter **SMA[serial number]** in the list with the found WLAN networks.
 - Enter the inverter WLAN password. Within the first ten feed-in hours and prior to completing the configuration by means of the installation assistant, you must use the standard WLAN password **SMA12345**. After the first ten feed-in hours or after completing the configuration by means of the installation assistant, you must use the device-specific WLAN password (WPA2-PSK) of the inverter. You find the WLAN password (WPA2-PSK) on the type label.
3. Enter the IP address **192.168.12.3** or, if your device supports mDNS services, **SMA[serial number].local** or **https://SMA[serial number]** in the address bar of the web browser and press the enter key.
 4. **i** **Web browser signals a security vulnerability**
 After the IP address has been confirmed by pressing the enter key, a message might appear indicating that the connection to the user interface of the inverter is not secure. SMA Solar Technology AG guarantees that calling up the user interface is secure.
 - Continue loading the user interface. The login page of the user interface opens.

4.2.3 Establishing a Connection via Ethernet in the local network

i New IP address for connecting with a local network

If the product is connected to a local network (e.g. via a router), the product will receive a new IP address. Depending on the type of configuration, the new IP address will be assigned automatically by the DHCP server (router) or manually by you. Upon completion of the configuration, the product can only be reached via the following access addresses:

- Generally applicable access address: IP address manually assigned or assigned by the DHCP server (router) (identification via network scanner software or network configuration of the router).
- Access address for Apple and Linux systems: **SMA[serial number].local** (e.g. **SMA0123456789.local**)
- Access address for Windows and Android systems: **https://SMA[serial number]** (e.g. **https://SMA0123456789**)

Requirements:

- The product must be connected to the local network via a network cable (e.g. via a router).
- The product must be integrated into the local network. Tip: There are various methods of integrating the product into the local network with the aid of the installation assistant.
- An end device (e.g. computer, tablet PC or smartphone) must be available.
- The end device must be in the same local network as the product.
- The respective latest version of one of the following web browsers must be installed: Chrome, Edge, Firefox, Internet Explorer or Safari.
- The SMA Grid Guard code of the Installer must be available for the changing of grid-relevant settings after completion of the first ten feed-in hours or installation assistant (see "Application for SMA Grid Guard Code" at www.SMA-Solar.com).

Procedure:

1. Open the web browser of your end device, enter the IP address of the inverter in the address line of the web browser and press the enter key.
 2.  **Web browser signals a security vulnerability**
After the IP address has been confirmed by pressing the enter key, a message might appear indicating that the connection to the user interface of the inverter is not secure. SMA Solar Technology AG guarantees that calling up the user interface is secure.
 - Continue loading the user interface.
- The login page of the user interface opens.

4.2.4 Establishing a Connection via WLAN in the Local Network** New IP address for connecting with a local network**

If the product is connected to a local network (e.g. via a router), the product will receive a new IP address. Depending on the type of configuration, the new IP address will be assigned automatically by the DHCP server (router) or manually by you. Upon completion of the configuration, the product can only be reached via the following access addresses:

- Generally applicable access address: IP address manually assigned or assigned by the DHCP server (router) (identification via network scanner software or network configuration of the router).
- Access address for Apple and Linux systems: SMA[serial number].local (e.g. SMA0123456789.local)
- Access address for Windows and Android systems: [https://SMA\[serial number\]](https://SMA[serial number]) (e.g. <https://SMA0123456789>)

Requirements:

- The product must be commissioned.
- The product must be integrated into the local network. Tip: There are various methods of integrating the product into the local network with the aid of the installation assistant.
- An end device (e.g. computer, tablet PC or smartphone) must be available.
- The end device must be in the same local network as the product.
- The respective latest version of one of the following web browsers must be installed: Chrome, Edge, Firefox, Internet Explorer or Safari.
- The SMA Grid Guard code of the Installer must be available for the changing of grid-relevant settings after completion of the first ten feed-in hours or installation assistant (see "Application for SMA Grid Guard Code" at www.SMA-Solar.com).

i **Importing and exporting files with end devices having an iOS operating system is not possible.**

For technical reasons, importing and exporting files (e.g. importing an inverter configuration, saving the current inverter configuration or exporting events and parameters) is not possible with mobile end devices having an iOS operating system.

- Use an end device that does not have an iOS operating system for importing and exporting files.

Procedure:

1. Enter the IP address of the inverter in the address bar of the web browser.

2. **i** **Web browser signals a security vulnerability**

After the IP address has been confirmed by pressing the enter key, a message might appear indicating that the connection to the user interface of the inverter is not secure. SMA Solar Technology AG guarantees that calling up the user interface is secure.

- Continue loading the user interface.
- The login page of the user interface opens.

4.3 Logging In and Out of the User Interface

After a connection to the user interface of the inverter has been established, the login page opens. Log onto the user interface as described below.

i **Usage of cookies**

For the correct display of the user interface, cookies are required. The cookies are used for convenience only. By using this user interface you agree to the placement of cookies.

Log in as Installer or User for the First Time

Procedure:

1. In the drop-down list **Language**, select the desired language.
2. In the **User group** drop-down list, select the entry **Installer** or **User**.
3. In the **New password** field, enter a new password for the selected user group.

4. In the **Repeat password** field, enter the new password again.
 5. Select **Login**.
- The **Configuring the Inverter** page opens.

Log in as the User or Installer

1. In the drop-down list **Language**, select the desired language.
 2. In the **User group** drop-down list, select the entry **Installer** or **User**.
 3. Enter the password in the field **Password**.
 4. Select **Login**.
- The start page of the user interface opens.

Log Out as the User or Installer

1. On the right-hand side of the menu bar, select the menu **User Settings**.
 2. In the subsequent context menu, select [**Logout**].
- The login page of the user interface opens. The logout was successful.

4.4 Start Page Design of the User Interface



Figure 2: Start page design of the user interface (example)

Position	Designation	Description
A	Menu	<p>Provides the following functions:</p> <ul style="list-style-type: none"> • Home Opens the user interface homepage • Instantaneous values Current measured values of the inverter • Device Parameters The various operating parameters of the inverter can be viewed and configured here depending on the user group. • Events All events that have occurred in the selected time period are displayed here. The event types are Information, Warning and Error. Currently existing events of the types Error and Warning will be additionally displayed in the Device status viewlet. However, only the higher-priority event is displayed. If, for example, there is a Warning and an Error present at the same time, only the Error will be displayed. • Device configuration Various settings for the inverter can be made here. The selection available is dependent on which user group you are logged in as and the operating system of the device with which the user interface has been called up. • Data You will find all data that is saved in the internal memory of the inverter or on an external storage medium on this page.
B	User settings	<p>Provides the following functions, depending on the user group logged in:</p> <ul style="list-style-type: none"> • Starting the installation assistant • SMA Grid Guard login • Logout
C	Help	<p>Provides the following functions:</p> <ul style="list-style-type: none"> • Displaying information on Open Source licenses used • Link to the website of SMA Solar Technology AG

Position	Designation	Description
D	Status bar	<p>Displays the following information:</p> <ul style="list-style-type: none"> • Inverter serial number • Inverter firmware version • IP address of the inverter within the local network and/or IP address of the inverter during WLAN connection • With WLAN connection: Signal strength of WLAN connection • User group logged in • Date and device time of the inverter
E	Current power and current consumption	<p>Temporal progression of the PV power and the power consumption of the household over the selected time period. Please note, the power consumption will only be displayed if an energy meter is installed in the PV system.</p>
F	Status display	<p>The various areas display information on the current status of the PV system.</p> <ul style="list-style-type: none"> • Device status Displays whether the inverter is currently in a fault-free operating state or whether there is an Error or Warning present. • Current power Displays the power currently being generated by the inverter. • Current consumption Displays the current consumption of the household if an energy meter is installed in the PV system. • Yield Displays the energy yield of the inverter. • Consumption Displays the energy consumption of the household if an energy meter is installed in the PV system. • Feed-in management Displays whether the inverter is currently limiting its active power. • Irradiation / wind speed Depending on the connected sensors, displays the current solar irradiation and/or wind speed. • Temperature measurement Depending on the connected sensors, displays the current temperature of the PV modules and/or the ambient temperature.

4.5 Displaying and Downloading the Stored Data

If an external storage device is plugged in, you can display and download the stored data.

Procedure:

1. Activate the user interface (see Section 4.2, page 22).
2. Log into the user interface (see Section 4.3, page 26).
3. Select the menu **Data**.
4. Select the folder **Data**.
5. To call up the data, select the respective folder and click on the required file.
6. To download the data, select the data type to be exported in the drop-down list. Then apply the time filter and select **Data export**.

4.6 Activating the Smart Inverter Screen

With the Smart Inverter Screen, the most important inverter data is displayed directly on the user interface login page. To activate the Smart Inverter Screen, proceed as listed in the following.

Procedure:

1. Activate the user interface (see Section 4.2, page 22).
 2. Log in as **Installer** or **User**.
 3. Select the menu **User Settings** (see Section 4.4, page 28) on the start page of the user interface.
 4. Select [**Smart Inverter Screen**].
- The Smart Inverter Screen has been activated.

4.7 Starting the Installation Assistant

QUALIFIED PERSON

The installation assistant leads you step-by-step through the steps necessary for the initial configuration of the inverter.

Layout of the installation assistant

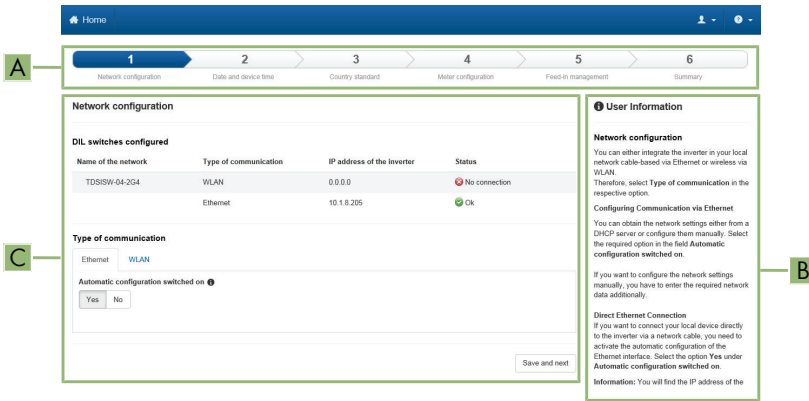

Figure 3: Layout of the installation assistant (example)

Position	Designation	Description
A	Configuration steps	Overview of the installation assistant steps. The number of steps depends on the type of device and the additionally installed modules. The current step is highlighted in blue.
B	User information	Information about the current configuration step and the setting options of the configuration step.
C	Configuration field	You can make settings in this field.

Requirement:

- When configuring after completion of the first ten feed-in hours or after exiting the installation assistant, the SMA Grid Guard code must be available in order to change the grid-relevant parameters (see "Application for SMA Grid Guard Code" at www.SMA-Solar.com).

Procedure:

1. Activate the user interface (see Section 4.2, page 22).
 2. Log in as **Installer**.
 3. Select the menu **User Settings** (see Section 4.4, page 28) on the start page of the user interface.
 4. In the context menu, select [**Starting the installation assistant**].
- The installation assistant will open.

4.8 Secure Power Supply Operation

4.8.1 Activating Secure Power Supply Operation

If an outlet and a switch for secure power supply operation are connected to the inverter, you can supply a load with current from the PV system in case of a grid failure during the day. If you activate the secure power supply operation, the inverter supplies loads that are connected to the outlet for secure power supply operation.

In case of overload, underload or insufficient solar irradiation, the voltage supply of the outlet is briefly interrupted. The inverter automatically attempts to reestablish the voltage supply 20 seconds after the interruption. This can lead to inadvertent starting of the load that is connected to the outlet. Ensure that the load connected to the outlet does not consume too much power. If necessary, reduce the power consumption of the load.

i In case of a grid failure during the night, secure power supply operation is not possible

During the night, secure power supply operation cannot be activated since the PV system does not produce power that is required to supply the load.

- In case of a grid failure during the night, do not activate secure power supply operation.
- Continue to operate the inverter on the utility grid and wait for restoration of grid operation.
- In the event of a persistent grid failure, switch to secure power supply operation after sunrise.

i Do not connect loads that require a stable electricity supply to the outlet for secure power supply operation

Secure power supply operation must not be used for loads that require a stable electricity supply. The power available during secure power supply operation depends on the solar irradiation on the PV system. Therefore, power output can fluctuate considerably depending on the weather or may not be available at all.

- Do not connect loads to the outlet for secure power supply operation if they are dependent on a stable electricity supply for reliable operation.

Procedure:

1. If no load is connected to the outlet, connect a load.

2. Turn the switch of the outlet to secure power supply operation.
 3. Wait one minute.
- The inverter commences secure power supply operation. As soon as the inverter supplies the outlet with power, the green LED flashes (1.5 s on and 0.5 s off) and the message **SPS-mode active** is shown in the display along with the amount of power being supplied from the inverter to the outlet. In addition, the control light of the outlet for secure power supply operation glows.
 - The green LED does not flash and no message that the secure power supply operation mode is activated appears on the display or the control lamp of the outlet does not glow?
The output power of the PV system is too low. Irradiation on the PV system is probably too low or the connected load requires more power than currently available.
 - Ensure that the outlet's switch is set to secure power supply operation.
 - If irradiation is too low, wait for it to increase.
 - Connect a load with lower power consumption to the outlet.
 - No voltage can be measured at the outlet?
 - Ensure that the outlet's switch is set to secure power supply operation.
 - Ensure that the switch, outlet and control light for secure power supply operation are correctly connected.

4.8.2 Deactivating Secure Power Supply Operation

1. If necessary, disconnect the load from the outlet.
 2. Turn the switch of the outlet to grid operation.
 - Grid operation is activated.
 3. Switch on the circuit breaker of the PV system.
- The inverter connects to the utility grid and starts feed-in operation.

4.9 Activate WPS Function

The WPS function can be used for different purposes:

- Automatic connection to a network (e.g. via router)
- Direct connection between the product and an end device

Depending on the intended application of the WPS function, the procedure for activation will vary.

Activating WPS function for automatic connection to a network

Requirements:

- WLAN must be activated in the product.
- WPS must be activated on the router.

Procedure:

1. Activate the user interface (see Section 4.2, page 22).
2. Log in as **Installer**.
3. Start the installation assistant (see Section 4.7, page 31).

4. Select **Network configuration**.
 5. Select **WPS for WLAN network** button in the **WLAN** tab.
 6. Select **Activate WPS**.
 7. Select **Save and next** and exit the installation assistant.
- The WPS function is activated and the automatic connection to the network can be established.

Activating the WPS function for direct connection to the end device.

- Activate the WPS function on the inverter. To do this, tap twice on the enclosure lid of the Connection Unit.
 - The blue LED flashes quickly for approx. two minutes. The WPS function is active during this time.

4.10 Switching WLAN On and Off

The inverter is equipped with an activated WLAN interface as standard. If you do not want to use WLAN, you can switch the WLAN function off and switch it on again whenever needed. In doing so, you can switch the WLAN direct connection and the WLAN connection in the local network on independently of each other.

i Switching on the WLAN function only possible via Ethernet connection

If you switch off both the WLAN function for the direct connection and for the connection in the local network, access to the inverter user interface and therefore reactivation of the WLAN interface is only possible via an Ethernet connection.

The basic procedure for changing operating parameters is explained in another section (see Section 4.13 "Changing Operating Parameters", page 37).

Switching WLAN Off

If you would like to switch the WLAN function off completely, you must switch off both the direct connection and the connection in the local network.

Procedure:

- To switch off the direct connection in the parameter group **PV system communication > WLAN**, select the parameter **Soft-access-point is turned on** and set this to **No**.
- To switch off the connection in the local network in the parameter group **PV system communication > WLAN**, select the parameter **WLAN is turned on** and set this to **No**.

Switching WLAN On

If you have switched the WLAN function for direct connection or for connection in the local network off, you can switch the WLAN function back on in accordance with the following procedure.

Requirement:

- If the WLAN function was previously switched off completely, the inverter must be connected to a computer or router via Ethernet.

Procedure:

- To switch on the WLAN direct connection, in the parameter group **PV system communication > WLAN**, select the parameter **Soft-access-point is turned on** and set this to **Yes**.
- To switch on the WLAN connection in the local network, in the parameter group **System communication > WLAN**, select the parameter **WLAN is turned on** and set this to **Yes**.

4.11 Switching the Dynamic Power Display Off

As standard, the inverter signals its power dynamically via the pulsing of the green LED. When doing so, the LED flashes on and off uniformly or is permanently lit at full power. The various gradations are related here to the set active power limit of the inverter. If this display is not desired, switch this function off in accordance with the following procedure. Once this has been done, the green LED is lit permanently to signalize feed-in operation.

The basic procedure for changing operating parameters is explained in another section (see Section 4.13 "Changing Operating Parameters", page 37).

Procedure:

- In the parameter group **Device > Operation**, select the parameter **Dynamic power display via green LED** and set this to **Off**.

4.12 Changing the Password

The password for the inverter can be changed for both user groups. Furthermore, the user group **Installer** can change the password for the user group **User** as well as its own password.

PV systems registered in a communication product

With PV systems that are registered in a communication product (e.g. Sunny Portal, Cluster Controller), you can also assign a new password for the user group **Installer** via the communication product. The password for the user group **Installer** is also the system password. If you assign a password for the user group **Installer** via the user interface of the inverter that does not correspond to the system password in the communication product, the inverter can no longer be reached by the communication product.

- Ensure that the password for the user group **Installer** is the same as the system password in the communication product.

Procedure:

1. Activate the user interface (see Section 4.2, page 22).
2. Log into the user interface (see Section 4.3, page 26).
3. Call up the menu **Device Parameters**.
4. Select [**Edit parameters**].
5. In the parameter group **User Rights > Access Control** change the password of the desired user group.
6. Select [**Save all**] to save the changes.

4.13 Changing Operating Parameters

The operating parameters of the inverter are set to certain values by default. You can change the operating parameters to optimize the performance of the inverter.

This section describes the basic procedure for changing operating parameters. Always change operating parameters as described in this section. Some function-sensitive parameters can only be viewed by qualified persons and can only be changed by qualified persons by entering the personal SMA Grid Guard code.

No configuration via Sunny Explorer

Sunny Explorer does not support the configuration of inverters with their own user interface. The inverter can be detected via Sunny Explorer, however it is expressly not recommended to use Sunny Explorer to configure this inverter. SMA Solar Technology AG does not accept liability for missing or incorrect data and possibly resulting yield losses.

- Use the user interface for the configuration of the inverter.

Requirements:

- Changes to grid-relevant parameters must be approved by the responsible grid operator.
- Changes to grid-relevant parameters must be approved by the responsible grid operator.

Procedure:

1. Activate the user interface (see Section 4.2, page 22).
 2. Log into the user interface (see Section 4.3, page 26).
 3. Call up the menu **Device Parameters**.
 4. Select [**Edit parameters**].
 5. Log in using the SMA Grid Guard code to change those parameters designated by a lock (only for installers):
 - Select the menu **User Settings** (see Section 4.4, page 28).
 - In the subsequent context menu, select [**SMA Grid Guard login**].
 - Enter the SMA Grid Guard code and select [**Login**].
 6. Expand the parameter group that contains the parameter which is to be configured.
 7. Change the desired parameters.
 8. Select [**Save all**] to save the changes.
- The inverter parameters are set.

Accepting the settings

Saving the made settings is indicated by an hourglass symbol on the user interface. If the DC voltage is sufficient, the data is transferred directly to the inverter and accepted. If the DC voltage is too low (e. g. in the evening), the settings are saved, but they cannot be directly transferred to or accepted by the inverter. As long as the inverter has not yet received and accepted the settings, the hourglass symbol will continue to be displayed on the user interface. The settings will be accepted when there is sufficient DC voltage applied and the inverter restarts. As soon as the hourglass symbol appears on the user interface, the settings have been saved. The settings will not be lost. You can log off of the user interface and leave the system.

4.14 Configuring the Country Data Set

⚠ QUALIFIED PERSON

As standard, the inverter is meant for connection to a utility grid with a 208 V wye connection or a 240 V split-phase system, and the associated country data set **UL1741/2016/120** is factory-set. If the default country data set does not correspond with the grid configuration, the country data set can be adapted to the connected grid configuration.

The basic procedure for changing operating parameters is explained in another section (see Section 4.13 "Changing Operating Parameters", page 37).

Grid configuration	Country data set
208 V delta connection	UL1741/2016/208
208 V wye connection	UL1741/2016/120
240 V delta connection	UL1741/2016/240
240 V split-phase system	UL1741/2016/120

Procedure:

- Select the parameter **Set country standard** and set the required country data set.

4.15 Activating of the Rapid Shutdown DC discharge function

The DC discharge function should be activated if an additional DC switch-disconnector between the inverter and the PV array is available. The additional DC switch-disconnector disconnects the PV array in the case of a rapid shutdown.

Procedure:

- Set the parameter **Rapid Shutdown Mode** or **Op.RssOpMode** to **On**.

4.16 Changing the Operating Mode of the Multifunction Relay

⚠ QUALIFIED PERSON

The default operating mode of the multifunction relay is **Fault indication (FltInd)**. If you decide to use another operating mode and have established the correct electrical connection for this operating mode and the associated connection variant, you will have to change the operating mode of the multifunction relay and make other settings, if necessary.

The basic procedure for changing operating parameters is explained in another section (see Section 4.13 "Changing Operating Parameters", page 37).

Procedure:

1. Call up the menu **Device Parameters**.
2. Select **[Edit parameters]**.

3. In the parameter group **Device > Multifunction relay > Operating mode** select the parameter **Operating mode of multifunction relay** or **Mlt.OpMode** and set the desired operating mode.
4. Once you have set the operating mode **Self-consumption** or **SelfCsmP**, you can configure other settings:
 - In the parameter group **Device > Multifunction relay > Self-consumption > Minimum On power** select the parameter **Minimum On power for MFR self-consumption** or **Mlt.MinOnPwr** and set the desired value. This will configure the power threshold from which a load is to be activated.
 - In the parameter group **Device > Multifunction relay > Self-consumption > Minimum power On time** select the parameter **Minimum power On time, MFR self-consumption** or **Mlt.MinOnPwrTmm** and set the desired value. This will configure the minimum time for which the power must have exceeded the minimum switch-on power threshold in order to trip activation of the load.
 - In the parameter group **Device > Multifunction relay > Self-consumption > Minimum On power** select the parameter **Minimum On time for MFR self-consumption** or **Mlt.MinOnTmm** and set the desired value. This will configure the minimum time for which the load remains activated.
5. If you have set the operating mode **Control via communication** or **ComCtl**, in the parameter group **Device > Multifunction relay > Control via communication > Status** select the parameter **Status of MFR with control via communication** or **Mlt.ComCtl.Sw** and set the desired value. This determines whether the multifunction relay can be controlled via a communication product.
6. If you have set the operating mode **Battery bank** or **BatCha**, make further settings:
 - In the parameter group **Device > Multifunction relay > Battery bank > Minimum On power** select the parameter **Minimum On power for MFR battery bank** or **Mlt.BatCha.Pwr** and set the desired value. This will configure the power threshold from which the battery is to be charged.
 - In the parameter group **Device > Multifunction relay > Battery bank > Minimum time before reconnection** select the parameter **Minimum time before reconnection of MFR battery bank** or **Mlt.BatCha.Tmm** and set the desired value. This will configure the minimum time which must elapse after charging the battery before the battery can be charged again.
7. Select [**Save all**] to save the changes.

4.17 Configuring the Modbus Function

QUALIFIED PERSON

The Modbus interface is deactivated by default and the communication ports 502 set.

In order to access SMA inverters with SMA Modbus® or SunSpec® Modbus®, the Modbus interface must be activated. After activating the interface, the communication ports of both IP protocols can be changed. For information on commissioning and configuration of the Modbus interface, see the Technical Information "SMA Modbus® Interface" or in the Technical Information "SunSpec® Modbus® Interface" at www.SMA-Solar.com.

For information on which Modbus registers are supported, see the Technical Descriptions "SMA Modbus® Interface" or "SunSpec® Modbus® Interface" at www.SMA-Solar.com.

i Data security during activated Modbus interface

If you activate the Modbus interface, there is a risk that unauthorized users may access and manipulate the data or devices in your PV system.

To ensure data security, take appropriate protective measures such as:

- Set up a firewall
- Close unnecessary network ports.
- Only enable remote access via VPN tunnel.
- Do not set up port forwarding at the communication port in use.
- In order to deactivate the Modbus interface, reset the inverter to the default settings or deactivate the activated parameter again.

Procedure:

- Activate the Modbus interface and adjust the communication ports if necessary (see the technical information "SMA Modbus® Interface" or "SunSpec® Modbus® Interface" at www.SMA-Solar.com).

4.18 Setting SMA OptiTrac Global Peak

⚠ QUALIFIED PERSON

For partially shaded PV modules, you should set the interval at which the inverter is to optimize the MPP of the PV system. If you do not want to use SMA OptiTrac Global Peak feature, you can deactivate the feature.

The basic procedure for changing operating parameters is explained in another section (see Section 4.13 "Changing Operating Parameters", page 37).

Procedure:

- In the parameter group **DC-side > DC settings > OptiTrac Global Peak**, set the parameter **Cycle time of the OptiTrac Global Peak algorithm** and set the required time interval. The ideal time interval is usually six minutes. This value should only be increased if the shading situation changes extremely slowly.
 - The inverter optimizes the MPP of the PV system at the predetermined time interval.
- In order to deactivate the SMA OptiTrac Global Peak feature, in the parameter group **DC-side > DC settings > OptiTrac Global Peak**, set the parameter **OptiTrac Global Peak switched on** to **Off**.

4.19 Deactivating the Arc-Fault Circuit Interrupter (AFCI)

⚠ QUALIFIED PERSON

The basic procedure for changing operating parameters is explained in another section (see Section 4.13 "Changing Operating Parameters", page 37).

Procedure:

- Select the parameter **AFCI switched on** or **AfcilsOn** and set to **No**.

4.20 Saving the Configuration in a File

You can save the current configuration of the inverter in a file. You can use this file as a data backup for this inverter and then import this file into this inverter again or another inverter from the same type or device family to configure the inverter. When saving, only the device parameters will be saved, not any passwords.

Procedure:

1. Activate the user interface (see Section 4.2, page 22).
2. Log into the user interface (see Section 4.3, page 26).
3. Select the menu **Device Configuration**.
4. Select [**Settings**].
5. In the context menu, select [**Saving the configuration in a file**].
6. Follow the instructions in the dialog.

4.21 Adopting a Configuration from a File

QUALIFIED PERSON

To configure the inverter, you can adopt the configuration from a file. To be able to do this, you must first save the configuration of another inverter from the same type or device family in a file (see Section 4.20 "Saving the Configuration in a File", page 41). When saving, only the device parameters will be adopted, not any passwords.

Requirements:

- Changes to grid-relevant parameters must be approved by the responsible grid operator.
- The SMA Grid Guard code must be available (see "Application for SMA Grid Guard Code" at www.SMA-Solar.com).

Procedure:

1. Activate the user interface (see Section 4.2, page 22).
2. Log into the user interface as an **Installer**.
3. Select the menu **Device Configuration**.
4. Select [**Settings**].
5. In the context menu, select [**Adopting the configuration from a file**].
6. Follow the instructions in the dialog.

4.22 Updating the Firmware

QUALIFIED PERSON

If no automatic update is set for the inverter in the communication product (e.g. SMA Data Manager, Cluster Controller, Sunny Portal) or via the user interface of the inverter, you have the option of carrying out a manual firmware update.

There are two options to update the firmware:

- Update the firmware via the user interface of the inverter.
- Update the firmware via USB flash drive.

Updating firmware via the user interface

Requirements:

- An update file with the desired inverter firmware must be available. The update file is, for example, available for download on the product page of the inverter at www.SMA-Solar.com. To download the update file, it is necessary to enter the serial number of the inverter.

Procedure:

1. Activate the user interface (see Section 4.2, page 22).
2. Log into the user interface (see Section 4.3, page 26).
3. Select the menu **Device Configuration**.
4. In the inverter row, click on the gear icon and select **Update firmware**.
5. Select [**Browse**] and select the update file for the inverter.
6. Select **Update firmware**.
7. Follow the instructions in the dialog.

Updating the Firmware via USB Flash Drive

Requirement:

- A USB flash drive with maximum 32 GB and file system FAT32 must be available.

Procedure:

1. Create an "UPDATE" folder on the USB stick.
2. Save the update file with the desired firmware in the "UPDATE" folder on the USB flash drive. The update file is, for example, available for download on the product page of the inverter at www.SMA-Solar.com. Make sure that only the update file to which the inverter is to be updated must be saved on the USB flash drive.

3.

DANGER

Danger to life due to high voltages

- Disconnect the inverter from any voltage sources and open the enclosure lid of the Connection Unit (see the inverter installation manual).

4. Insert the USB flash drive in the USB port on the communication assembly.

5. Commission the inverter (see inverter installation manual).
 - During start-up phase of the inverter, the desired firmware is being installed. At the same time, the status of the update is shown in the display: **Update status: xxxxxxxx**
 - Once the desired firmware has been installed in the inverter, the status **successful** is shown in the display.
6. If the message **error occurred** is shown in the display, perform the firmware update again.

7.

 **DANGER**

Danger to life due to high voltages

- Disconnect the inverter from any voltage sources and open the enclosure lid of the Connection Unit (see the inverter installation manual).

8. Pull the USB flash drive out of the USB port.
9. Commission the inverter (see inverter installation manual).

5 Cleaning the Inverter

NOTICE

Damage due to cleaning agents

The use of cleaning agents may cause damage to the product and its components.

- Clean the product and all its components only with a cloth moistened with clear water.
- Ensure that the inverter is free of dust, foliage and other dirt.

6 Troubleshooting

6.1 Forgotten Password

If you have forgotten the password for the inverter, you can unlock the inverter with a Personal Unlocking Key (PUK). For each inverter, there is one PUK for each user group (**User** and **Installer**).
Tip: With PV systems in Sunny Portal, you can also assign a new password via Sunny Portal for the user group **Installer**. The password for the user group **Installer** is the same as the system password in Sunny Portal.

Procedure:

1. Request PUK (application form available at www.SMA-Solar.com).
2. Activate the user interface (see Section 4.2, page 22).
3. Enter the PUK instead of the password into the field **Password**.
4. Select **Login**.
5. Call up the menu **Device Parameters**.
6. Select [**Edit parameters**].
7. In the parameter group **User Rights > Access Control** change the password of the desired user group.
8. Select [**Save all**] to save the changes.

PV Systems in Sunny Portal

The password for the user group **Installer** is also the system password for the PV system in Sunny Portal. Changing the password of the user group **Installer** can lead to the inverter no longer being able to be reached by Sunny Portal.

- Assign the changed password of the user group **Installer** as the new system password in Sunny Portal (see the Sunny Portal user manual at www.SMA-Solar.com).

6.2 Event Messages

Event number	Message, cause and corrective measures
101 to 105	<div data-bbox="321 253 656 291" style="background-color: #cccccc; padding: 2px;">⚠ QUALIFIED PERSON</div> <p data-bbox="321 310 432 336">Grid fault</p> <p data-bbox="321 348 1076 406">The grid voltage or grid impedance at the connection point of the inverter is too high. The inverter has disconnected from the utility grid.</p> <p data-bbox="321 418 559 444">Corrective measures:</p> <ul data-bbox="342 456 1085 583" style="list-style-type: none"> • Ensure that the correct country data set has been configured (see Section 4.14, page 38). • Check whether the grid voltage at the connection point of the inverter is permanently in the permissible range. <p data-bbox="370 591 1089 713">If the grid voltage is outside the permissible range due to local grid conditions, contact the grid operator. The grid operator must agree with an adjustment of the voltage at the feed-in point or with a change of the monitored operating limits.</p> <p data-bbox="370 725 1089 782">If the grid voltage is permanently within the permissible range and this message is still displayed, contact the Service (see Section 9, page 72).</p>
202 to 206	<div data-bbox="321 800 656 838" style="background-color: #cccccc; padding: 2px;">⚠ QUALIFIED PERSON</div> <p data-bbox="321 857 432 883">Grid fault</p> <p data-bbox="321 895 1089 986">The utility grid has been disconnected, the AC cable is damaged or the grid voltage at the connection point of the inverter is too low. The inverter has disconnected from the utility grid.</p> <p data-bbox="321 998 559 1024">Corrective measures:</p> <ul data-bbox="342 1036 1085 1234" style="list-style-type: none"> • Make sure that the circuit breaker is switched on. • Ensure that the AC cable is not damaged and that it is connected correctly. • Ensure that the country data set has been configured correctly. • Check whether the grid voltage at the connection point of the inverter is permanently in the permissible range. <p data-bbox="370 1242 1089 1364">If the grid voltage is outside the permissible range due to local grid conditions, contact the grid operator. The grid operator must agree with an adjustment of the voltage at the feed-in point or with a change of the monitored operating limits.</p> <p data-bbox="370 1376 1089 1433">If the grid voltage is permanently within the permissible range and this message is still displayed, contact the Service (see Section 9, page 72).</p>

Event number	Message, cause and corrective measures
401 to 404	<p data-bbox="326 199 652 234">⚠ QUALIFIED PERSON</p> <p data-bbox="326 251 431 286">Grid fault</p> <p data-bbox="326 295 1113 355">The inverter has disconnected from the utility grid. A stand-alone grid or a very large change in the power frequency was detected.</p> <p data-bbox="326 364 554 399">Corrective measures:</p> <ul data-bbox="338 399 1113 434" style="list-style-type: none"><li data-bbox="338 399 1113 434">• Check the grid connection for significant short-term frequency fluctuations.
501	<p data-bbox="326 442 652 477">⚠ QUALIFIED PERSON</p> <p data-bbox="326 494 431 529">Grid fault</p> <p data-bbox="326 538 1113 598">The power frequency is not within the permissible range. The inverter has disconnected from the utility grid.</p> <p data-bbox="326 607 554 642">Corrective measures:</p> <ul data-bbox="338 642 1113 876" style="list-style-type: none"><li data-bbox="338 642 1113 703">• If possible, check the power frequency and observe how often fluctuations occur. If fluctuations occur frequently and this message is displayed often, contact the grid operator and request approval to change the operating parameters of the inverter. If the grid operator gives his approval, discuss any changes to the operating parameters with Service (see Section 9, page 72).
601	<p data-bbox="326 885 652 920">⚠ QUALIFIED PERSON</p> <p data-bbox="326 937 431 972">Grid fault</p> <p data-bbox="326 980 1113 1041">The inverter has detected an excessively high proportion of direct current in the grid current.</p> <p data-bbox="326 1050 554 1085">Corrective measures:</p> <ul data-bbox="338 1085 1113 1192" style="list-style-type: none"><li data-bbox="338 1085 1113 1119">• Check the grid connection for direct current.<li data-bbox="338 1119 1113 1192">• If this message is displayed frequently, contact the grid operator and check whether the monitoring threshold on the inverter can be raised.

Event number	Message, cause and corrective measures
701	<p data-bbox="326 199 652 234">⚠ QUALIFIED PERSON</p> <p data-bbox="326 251 745 286">Freq. not permitted > Check parameter</p> <p data-bbox="326 295 1090 355">The power frequency is not within the permissible range. The inverter has disconnected from the utility grid.</p> <p data-bbox="326 364 560 390">Corrective measures:</p> <ul data-bbox="338 399 1090 624" style="list-style-type: none"> <li data-bbox="338 399 1090 460">• If possible, check the power frequency and observe how often fluctuations occur. If fluctuations occur frequently and this message is displayed often, contact the grid operator and request approval to change the operating parameters of the inverter. <li data-bbox="338 564 1090 624">• If the grid operator gives his approval, discuss any changes to the operating parameters with Service (see Section 9, page 72).
1001	<p data-bbox="326 642 652 677">⚠ QUALIFIED PERSON</p> <p data-bbox="326 694 696 729">L/N swapped > Check connection</p> <p data-bbox="326 737 714 763">The connection of L and N is swapped.</p> <p data-bbox="326 772 560 798">Corrective measures:</p> <ul data-bbox="338 807 1065 841" style="list-style-type: none"> <li data-bbox="338 807 1065 841">• Ensure that L and N are correctly connected (see installation manual).
1302	<p data-bbox="326 859 652 894">⚠ QUALIFIED PERSON</p> <p data-bbox="326 911 1102 972">Waiting for grid voltage > Installation failure grid connection > Check grid and fuses</p> <p data-bbox="326 980 535 1006">L or N not connected.</p> <p data-bbox="326 1015 560 1041">Corrective measures:</p> <ul data-bbox="338 1050 1102 1189" style="list-style-type: none"> <li data-bbox="338 1050 1102 1085">• Ensure that L and N are connected (see installation manual). <li data-bbox="338 1093 1102 1154">• Ensure that the AC conductors are not damaged and correctly connected (see installation manual). <li data-bbox="338 1163 1102 1189">• Make sure that the circuit breaker is switched on.
1501	<p data-bbox="326 1206 652 1241">⚠ QUALIFIED PERSON</p> <p data-bbox="326 1258 585 1293">Reconnection fault grid</p> <p data-bbox="326 1302 1090 1397">The changed country data set or the value of a parameter you have set does not correspond to the local requirements. The inverter cannot connect to the utility grid.</p> <p data-bbox="326 1406 560 1432">Corrective measures:</p> <ul data-bbox="338 1440 1102 1501" style="list-style-type: none"> <li data-bbox="338 1440 1102 1501">• Ensure that the country data set has been configured correctly. To do this, select the parameter Set country standard and check the value.

Event number	Message, cause and corrective measures
3301 to 3303	<p data-bbox="321 196 656 239">⚠ QUALIFIED PERSON</p> <p data-bbox="321 256 539 282">Unstable operation</p> <p data-bbox="321 296 1098 357">There is not enough power at the DC input of the inverter for stable operation. The inverter cannot connect to the utility grid.</p> <p data-bbox="321 366 558 392">Corrective measures:</p> <ul data-bbox="342 401 1063 508" style="list-style-type: none">• Ensure that the PV array is designed correctly.• Ensure that the PV array is not covered by snow or otherwise shaded.• Ensure that the PV array is free of errors.
3401 to 3407	<p data-bbox="321 517 656 560">⚠ QUALIFIED PERSON</p> <p data-bbox="321 578 765 604">DC overvoltage > Disconnect generator</p> <p data-bbox="321 618 900 644">Overvoltage at the DC input. This can destroy the inverter.</p> <p data-bbox="321 652 1005 678">This message is signalized additionally by rapid flashing of the LEDs.</p> <p data-bbox="321 687 558 713">Corrective measures:</p> <ul data-bbox="342 722 1098 1095" style="list-style-type: none">• Disconnect the inverter from voltage sources immediately (see installation manual).• Check whether the DC voltage is below the maximum input voltage of the inverter. If the DC voltage is below the maximum input voltage of the inverter, reconnect the terminal block with the connected DC conductors to the inverter.• If the DC voltage exceeds the maximum input voltage of the inverter, ensure that the PV array has been correctly rated or contact the installer of the PV array.• If this message is repeated frequently, contact the Service (see Section 9, page 72).
3501	<p data-bbox="321 1104 656 1147">⚠ QUALIFIED PERSON</p> <p data-bbox="321 1164 724 1190">Insulation failure > Check generator</p> <p data-bbox="321 1199 882 1225">The inverter has detected a ground fault in the PV array.</p> <p data-bbox="321 1234 558 1260">Corrective measures:</p> <ul data-bbox="342 1269 1032 1303" style="list-style-type: none">• Check the PV system for ground faults (see Section 6.3, page 64).

Event number	Message, cause and corrective measures
3601	<p data-bbox="321 192 656 239">⚠ QUALIFIED PERSON</p> <p data-bbox="321 244 765 291">High discharge curr. > Check generator</p> <p data-bbox="321 296 1060 361">The leakage current of the inverter and the PV array is too high. There is a ground fault, a residual current or a malfunction.</p> <p data-bbox="321 366 1094 465">The inverter interrupts feed-in operation immediately after exceeding a threshold. When the fault is eliminated, the inverter automatically reconnects to the utility grid.</p> <p data-bbox="321 470 559 499">Corrective measures:</p> <ul data-bbox="342 505 1036 534" style="list-style-type: none"> • Check the PV system for ground faults (see Section 6.3, page 64).
3701	<p data-bbox="321 539 656 586">⚠ QUALIFIED PERSON</p> <p data-bbox="321 591 749 638">Resid.curr.too.high > Check generator</p> <p data-bbox="321 644 1106 708">The inverter has detected a residual current due to temporary grounding of the PV array.</p> <p data-bbox="321 713 559 743">Corrective measures:</p> <ul data-bbox="342 748 1036 777" style="list-style-type: none"> • Check the PV system for ground faults (see Section 6.3, page 64).
3801	<p data-bbox="321 788 656 835">⚠ QUALIFIED PERSON</p> <p data-bbox="321 840 707 887">DC overcurrent > Check generator</p> <p data-bbox="321 892 1076 921">Overcurrent at the DC input. The inverter briefly interrupts feed-in operation.</p> <p data-bbox="321 927 559 956">Corrective measures:</p> <ul data-bbox="342 961 1101 1025" style="list-style-type: none"> • If this message is displayed frequently, ensure that the PV array has been correctly rated and wired.
3901 to 3902	<p data-bbox="321 1036 656 1083">⚠ QUALIFIED PERSON</p> <p data-bbox="321 1088 909 1135">Waiting for DC start conditions > Start cond. not met</p> <p data-bbox="321 1140 912 1170">The feed-in conditions for the utility grid are not yet fulfilled.</p> <p data-bbox="321 1175 559 1204">Corrective measures:</p> <ul data-bbox="342 1209 1069 1447" style="list-style-type: none"> • Ensure that the PV array is not covered by snow or otherwise shaded. • Wait for higher irradiation. • If this message is displayed frequently in the morning, increase the voltage limit for starting grid feed-in. Change the parameter Critical voltage to start feed-in. • If this message is displayed frequently with medium irradiation, ensure that the PV array is correctly rated.

Event number	Message, cause and corrective measures
4301	<p data-bbox="346 204 654 239">⚠ QUALIFIED PERSON</p> <p data-bbox="321 256 798 284">Electric arc detected > Check DC generator</p> <p data-bbox="321 296 1066 354">The inverter has detected an electric arc. The inverter interrupts grid feed-in and cannot connect to the utility grid.</p> <p data-bbox="321 366 559 394">Corrective measures:</p> <ul data-bbox="342 404 1044 461" style="list-style-type: none"> • Resetting the operation inhibition after detection of an arc fault (see Section 6.4, page 68).
6512	<p data-bbox="321 475 830 503">Minimum operating temperature not reached</p> <p data-bbox="321 515 1042 574">The inverter will only recommence grid feed-in once the temperature has reached at least -25°C.</p>
6701 to 6702	<p data-bbox="346 593 654 628">⚠ QUALIFIED PERSON</p> <p data-bbox="321 645 611 673">Communication disturbed</p> <p data-bbox="321 685 1082 743">Error in the communication processor, the inverter continues feeding in, however. The cause must be determined by the Service.</p> <p data-bbox="321 755 559 782">Corrective measures:</p> <ul data-bbox="342 793 1107 850" style="list-style-type: none"> • If this message is displayed frequently, contact the Service (see Section 9, page 72).
6803	<p data-bbox="346 873 654 907">⚠ QUALIFIED PERSON</p> <p data-bbox="321 925 693 953">Self-diagnosis > Input A defective</p> <p data-bbox="321 965 559 992">Corrective measures:</p> <ul data-bbox="342 1003 1097 1098" style="list-style-type: none"> • Check whether a string is connected to input A. If a string that once was connected is not used anymore, the string-failure detection must be reset. • Contact the Service (see Section 9, page 72).
6903	<p data-bbox="346 1117 654 1152">⚠ QUALIFIED PERSON</p> <p data-bbox="321 1170 691 1197">Self-diagnosis > Input B defective</p> <p data-bbox="321 1209 559 1237">Corrective measures:</p> <ul data-bbox="342 1248 1097 1343" style="list-style-type: none"> • Check whether a string is connected to input B. If a string that once was connected is not used anymore, the string-failure detection must be reset. • Contact the Service (see Section 9, page 72).
7106	<p data-bbox="321 1355 527 1383">Update file defect.</p> <p data-bbox="321 1395 1082 1454">The update file is defective. The update failed. The inverter continues to feed in.</p>
7110	<p data-bbox="321 1466 555 1494">No update file found</p> <p data-bbox="321 1506 1066 1565">No new update file was found on the SD memory card. The update failed. The inverter continues to feed in.</p>

Event number	Message, cause and corrective measures
7112	Update file successfully copied
7113	The memory card is full or write-protected
7303	<p>⚠ QUALIFIED PERSON</p> <p>Update main CPU failed The cause must be determined by the Service.</p> <p>Corrective measures:</p> <ul style="list-style-type: none"> • Contact the Service (see Section 9, page 72).
7324	<p>⚠ QUALIFIED PERSON</p> <p>Wait for update conditions The testing of the update conditions was not successful. The firmware update package is not suitable for this inverter.</p> <p>Corrective measures:</p> <ul style="list-style-type: none"> • Retry update. • Ensure that the selected update file is suitable for this inverter. • If this message is displayed again, contact the Service (see Section 9, page 72).
7331	<p>Update transport started Update file is being copied.</p>
7332	<p>Update transport successful Update file was copied successfully to the inverter's internal memory.</p>
7333	<p>⚠ QUALIFIED PERSON</p> <p>Update transport failed Update file could not be copied to the inverter's internal memory. In the event of connection with the inverter via WLAN, a poor connection quality can be the cause.</p> <p>Corrective measures:</p> <ul style="list-style-type: none"> • Retry update. • For WLAN connection, improve the WLAN connection quality (e.g. via SMA Antenna Extension Kit) or establish connection with the inverter via Ethernet. • If this message is displayed again, contact the Service (see Section 9, page 72).
7340	Update communication failed

Event number	Message, cause and corrective measures
7347	<p>⚠ QUALIFIED PERSON</p> <p>Incompatible file The configuration file is not suitable for this inverter.</p> <p>Corrective measures:</p> <ul style="list-style-type: none"> • Ensure that the selected configuration file is suitable for this inverter. • Retry import.
7348	<p>⚠ QUALIFIED PERSON</p> <p>Incorrect file format The configuration file is not of the required format or is damaged.</p> <p>Corrective measures:</p> <ul style="list-style-type: none"> • Ensure that the selected configuration file is of the required format and is not damaged. • Retry import.
7350	<p>Transfer of a configuration file has started The configuration file is being transferred.</p>
7351	<p>Update WLAN The inverter is updating the WLAN module.</p>
7352	<p>⚠ QUALIFIED PERSON</p> <p>Update of WLAN not successful The update of the WLAN module failed.</p> <p>Corrective measures:</p> <ul style="list-style-type: none"> • Retry update. • If this message is displayed again, contact the Service (see Section 9, page 72).
7353	<p>Update time zone database The inverter is updating the time zone database.</p>
7354	<p>⚠ QUALIFIED PERSON</p> <p>Update of time zone database not successful The update of the time zone database failed.</p> <p>Corrective measures:</p> <ul style="list-style-type: none"> • Retry update. • If this message is displayed again, contact the Service (see Section 9, page 72).

Event number	Message, cause and corrective measures
7355	<p>Update WebUI</p> <p>The inverter is updating the inverter user interface.</p>
7356	<p>⚠ QUALIFIED PERSON</p> <p>Update of the WebUI not successful</p> <p>The update of the inverter user interface failed.</p> <p>Corrective measures:</p> <ul style="list-style-type: none"> • Retry update. • If this message is displayed again, contact the Service (see Section 9, page 72).
7619	<p>⚠ QUALIFIED PERSON</p> <p>Communication fault with meter unit > Check communication to meter</p> <p>The inverter is not receiving any data from the energy meter.</p> <p>Corrective measures:</p> <ul style="list-style-type: none"> • Ensure that the energy meter is correctly integrated into the same network as the inverter (see energy meter manual). • For WLAN connection, improve the WLAN connection quality (e.g. via SMA Antenna Extension Kit) or connect the inverter with the DHCP server (router) via Ethernet.
8003	<p>⚠ QUALIFIED PERSON</p> <p>Active power limited derating</p> <p>The inverter has reduced its power output for more than ten minutes due to excessive temperature.</p> <p>Corrective measures:</p> <ul style="list-style-type: none"> • Clean the cooling fins on the rear of the enclosure and the air ducts on the top using a soft brush. • Ensure that the inverter has sufficient ventilation. • Ensure that the ambient temperature +45°C (113°F) has not been exceeded. • Ensure that the inverter is not exposed to direct solar irradiation.

Event number	Message, cause and corrective measures
8206	<p>⚠ QUALIFIED PERSON</p> <p>Electr. arc detected > Please confirm by tapping</p> <p>The inverter has detected an electric arc and was recommissioned after a disconnection. By tapping, you are confirming that you have repaired any possible damage to PV modules, DC conductors or plugs in the PV system.</p> <p>Corrective measures:</p> <ul style="list-style-type: none"> • Tap on the enclosure lid of the Connection Unit within ten seconds of the message appearing in order to recommission the inverter.
8503	<p>⚠ QUALIFIED PERSON</p> <p>Self-diagnosis > Input C defective</p> <p>Corrective measures:</p> <ul style="list-style-type: none"> • Check whether a string is connected to input C. If a string that once was connected is not used anymore, the string-failure detection must be reset. • Contact the Service (see Section 9, page 72).
8708	<p>⚠ QUALIFIED PERSON</p> <p>Timeout in communication for active power limitation</p> <p>Communication to the system control absent. Depending on the fall-back setting, either the last received values will be retained or the active power will be limited to the set percentage value of the inverter nominal power.</p> <p>Corrective measures:</p> <ul style="list-style-type: none"> • Ensure that the connection to the system manager (e.g. Sunny Home Manager) is intact and that no cables are damaged or that no plugs have been pulled.
8801 to 8803	<p>No display</p> <p>No information can be shown on the display.</p>
9002	<p>⚠ QUALIFIED PERSON</p> <p>SMA Grid Guard code invalid</p> <p>The SMA Grid Guard code entered is incorrect. The operating parameters are still protected and cannot be changed.</p> <p>Corrective measures:</p> <ul style="list-style-type: none"> • Enter the correct SMA Grid Guard code.
9003	<p>Grid parameter locked</p> <p>Changes to the grid parameters are now blocked. In order to be able to make changes to the grid parameters, from now on you must log in using the SMA Grid Guard code.</p>

Event number	Message, cause and corrective measures
9005	<p data-bbox="346 204 654 239">⚠ QUALIFIED PERSON</p> <p data-bbox="321 256 1015 282">Changing of grid parameters not possible > Ensure DC supply</p> <p data-bbox="321 296 730 322">This error can have the following causes:</p> <ul data-bbox="342 335 1052 395" style="list-style-type: none"> <li data-bbox="342 335 826 361">• The parameters to be changed are protected. <li data-bbox="342 369 1052 395">• The DC voltage at the DC input is not sufficient to run the main CPU. <p data-bbox="321 409 559 435">Corrective measures:</p> <ul data-bbox="342 447 1026 539" style="list-style-type: none"> <li data-bbox="342 447 703 473">• Enter the SMA Grid Guard code. <li data-bbox="342 482 1026 539">• Ensure that at least the DC start voltage is available (green LED is flashing, pulsing or glowing).
9202	<p data-bbox="346 560 654 595">⚠ QUALIFIED PERSON</p> <p data-bbox="321 612 547 638">SPS AC overvoltage</p> <p data-bbox="321 652 1097 713">An AC source has been connected to the socket connection for secure power supply operation.</p> <p data-bbox="321 727 559 753">Corrective measures:</p> <ul data-bbox="342 765 1015 817" style="list-style-type: none"> <li data-bbox="342 765 1015 817">• Check the connection at the SPS slots, and make any necessary corrections.
9203	<p data-bbox="346 838 654 873">⚠ QUALIFIED PERSON</p> <p data-bbox="321 890 721 916">Short circuit in the SPS power outlet</p> <p data-bbox="321 930 1103 1017">The maximum initial load has been overshoot or the appliance's initial current is above the maximum permissible load current of the connection for secure power supply operation for more than 5 s.</p> <p data-bbox="321 1031 559 1057">Corrective measures:</p> <ul data-bbox="342 1069 1073 1130" style="list-style-type: none"> <li data-bbox="342 1069 1073 1095">• Reduce the load at the connection for secure power supply operation. <li data-bbox="342 1104 968 1130">• If necessary, select an appliance with a lower initial current.
10110	<p data-bbox="321 1150 675 1177">Time synchronization failed: [x]</p> <p data-bbox="321 1190 962 1216">No time information could be called up from the set NTP server.</p> <p data-bbox="321 1230 559 1256">Corrective measures:</p> <ul data-bbox="342 1269 1064 1361" style="list-style-type: none"> <li data-bbox="342 1269 891 1295">• Ensure that the NTP server was configured correctly. <li data-bbox="342 1303 1064 1361">• Ensure that the inverter is integrated into a local network with Internet connection.

Event number	Message, cause and corrective measures
10248 to 10249	<p>Load reduced through device reduction or increase of query interval</p> <p>The network is busy. Data exchange between the devices is not at an optimum and is greatly delayed.</p> <p>Corrective measures:</p> <ul style="list-style-type: none"> • Reduce the number of devices in the network. • If necessary, increase the data query intervals. • If necessary, reduce the number of devices in the network.
10250	<p>⚠ QUALIFIED PERSON</p> <p>[Interface]: package error rate [ok / high]</p> <p>The package error rate has changed. If the package error rate is high, the network is overloaded or the connection to the network switch or DHCP server (router) is disturbed.</p> <p>Corrective measures if the package error rate is high:</p> <ul style="list-style-type: none"> • Ensure that with an Ethernet connection, the network cable and the network connector are not damaged and that the network connectors are correctly plugged. • If necessary, increase the data query intervals. • If necessary, reduce the number of devices in the network.
10251	<p>[Interface]: communication status goes to [OK / Warning / Error / Not connected]</p> <p>The communication status to the network switch or DHCP server (router) has changed. An additional error message may be displayed.</p>
10252	<p>⚠ QUALIFIED PERSON</p> <p>[Interface]: communication disrupted</p> <p>There is no valid signal on the network line.</p> <p>Corrective measures:</p> <ul style="list-style-type: none"> • Ensure that with an Ethernet connection, the network cable and the network connector are not damaged and that the network connectors are correctly plugged. • Ensure that the DHCP server (router) and any network switches are signaling correct operation.

Event number	Message, cause and corrective measures
10253	<p>⚠ QUALIFIED PERSON</p> <p>[Interface]: connection speed goes to [100 Mbit / 10 Mbit]</p> <p>The data transfer rate has changed. The cause for the status [10 Mbit] can be a defective plug, a defective cable or the pulling or plugging of the network connector.</p> <p>Corrective measures if the status is [10 Mbit]:</p> <ul style="list-style-type: none"> • Ensure that with an Ethernet connection, the network cable and the network connector are not damaged and that the network connectors are correctly plugged. • Ensure that the DHCP server (router) and any network switches are signaling correct operation.
10254	<p>⚠ QUALIFIED PERSON</p> <p>[Interface]: duplex mode goes to [Full / Half]</p> <p>The duplex mode (data transfer mode) has changed. The cause for the status [Half] can be a defective plug, a defective cable or the pulling or plugging of the network connector.</p> <p>Corrective measures if the status is [Half]:</p> <ul style="list-style-type: none"> • Ensure that with an Ethernet connection, the network cable and the network connector are not damaged and that the network connectors are correctly plugged. • Ensure that the DHCP server (router) and any network switches are signaling correct operation.
10255	<p>[Interface]: Network load OK</p> <p>The network load has returned to a normal range after being busy.</p>
10282	<p>[User group]-Login via [protocol] locked</p> <p>After several incorrect login attempts, login has been blocked for a limited time. In this case, the User login will be blocked for 15 minutes, the Grid Guard login for 12 hours.</p> <p>Corrective measures:</p> <ul style="list-style-type: none"> • Wait until the given time has expired and then retry login.
10283	<p>WLAN module faulty</p> <p>The WLAN module integrated in the inverter is defective.</p> <p>Corrective measures:</p> <ul style="list-style-type: none"> • Contact the Service (see Section 9, page 72).

Event number	Message, cause and corrective measures
10284	<p data-bbox="321 196 656 239">⚠ QUALIFIED PERSON</p> <p data-bbox="321 253 666 288">No WLAN connection possible</p> <p data-bbox="321 295 1085 352">The inverter does not currently have a WLAN connection to the selected network.</p> <p data-bbox="321 364 559 392">Corrective measures:</p> <ul data-bbox="342 401 1098 633" style="list-style-type: none"> <li data-bbox="342 401 1098 491">• Ensure that the SSID, the WLAN password and the encryption method have been entered correctly. The encryption method is specified by your WLAN router or WLAN Access Point and can be changed there. <li data-bbox="342 499 1098 557">• Ensure that the WLAN router or WLAN Access Point is in range and is signaling correct operation. <li data-bbox="342 565 1098 633">• If this message is displayed often, improve the WLAN connection by using a WLAN repeater (e.g. SMA Antenna Extension Kit).
10285	<p data-bbox="321 644 660 678">WLAN connection established</p> <p data-bbox="321 685 974 716">Connection to the selected WLAN network has been established.</p>
10286	<p data-bbox="321 727 656 770">⚠ QUALIFIED PERSON</p> <p data-bbox="321 784 574 819">WLAN connection lost</p> <p data-bbox="321 826 956 854">The inverter has lost WLAN connection to the selected network.</p> <p data-bbox="321 861 559 888">Corrective measures:</p> <ul data-bbox="342 897 1098 1067" style="list-style-type: none"> <li data-bbox="342 897 1098 925">• Ensure that the WLAN router or WLAN Access Point is still active. <li data-bbox="342 933 1098 991">• Ensure that the WLAN router or WLAN Access Point is in range and is signaling correct operation. <li data-bbox="342 999 1098 1067">• If this message is displayed often, improve the WLAN connection by using a WLAN repeater (e.g. SMA Antenna Extension Kit).
10339	<p data-bbox="321 1078 561 1112">Webconnect enabled</p> <p data-bbox="321 1119 1079 1182">The inverter can communicate with Sunny Portal without an additional SMA communications product (e.g. Cluster Controller).</p>
10340	<p data-bbox="321 1192 567 1227">Webconnect disabled</p> <p data-bbox="321 1234 1098 1324">The Webconnect function has been switched off. This means that the inverter can not communicate with Sunny Portal without an additional SMA communications product (e.g. Cluster Controller).</p> <ul data-bbox="342 1333 1098 1394" style="list-style-type: none"> <li data-bbox="342 1333 1098 1394">• If the inverter is to communicate with Sunny Portal without an additional SMA communication product, switch the Webconnect function on.

Event number	Message, cause and corrective measures
10341	<p>Webconnect error: no connection</p> <p>It is likely that there is an error in the network settings.</p> <p>Corrective measures:</p> <ul style="list-style-type: none"> • Check the network components (DLAN, WLAN Access Point etc.). • Ensure that the following ports are not blocked: <ul style="list-style-type: none"> - Registrar: ied.sma.de:9523 - Proxy: ied.sma.de:9523 - Stun: stun.sma.de:3478 - Domain: ied.sma.de (for SIP URI)
10343	<p>Webconnect error: Default gateway not configured</p> <p>It is likely that there is an error in the network settings.</p> <p>Corrective measures:</p> <ul style="list-style-type: none"> • Check the network components (DLAN, WLAN Access Point etc.). • Ensure that the following ports are not blocked: <ul style="list-style-type: none"> - Registrar: ied.sma.de:9523 - Proxy: ied.sma.de:9523 - Stun: stun.sma.de:3478 - Domain: ied.sma.de (for SIP URI)
10344	<p>Webconnect error: DNS server not configured</p> <p>It is likely that there is an error in the network settings.</p> <p>Corrective measures:</p> <ul style="list-style-type: none"> • Check the network components (DLAN, WLAN Access Point etc.). • Ensure that the following ports are not blocked: <ul style="list-style-type: none"> - Registrar: ied.sma.de:9523 - Proxy: ied.sma.de:9523 - Stun: stun.sma.de:3478 - Domain: ied.sma.de (for SIP URI)
10345	<p>No reply to DNS request</p> <p>It is likely that there is an error in the network settings.</p> <p>Corrective measures:</p> <ul style="list-style-type: none"> • Check the network components (DLAN, WLAN Access Point etc.). • Ensure that the following ports are not blocked: <ul style="list-style-type: none"> - Registrar: ied.sma.de:9523 - Proxy: ied.sma.de:9523 - Stun: stun.sma.de:3478 - Domain: ied.sma.de (for SIP URI)

Event number	Message, cause and corrective measures
10346	<p data-bbox="321 201 678 230">SIP proxy DNS resolution failed</p> <p data-bbox="321 239 851 269">It is likely that there is an error in the network settings.</p> <p data-bbox="321 277 559 307">Corrective measures:</p> <ul data-bbox="342 315 1029 527" style="list-style-type: none"><li data-bbox="342 315 1029 345">• Check the network components (DLAN, WLAN Access Point etc.).<li data-bbox="342 354 842 527">• Ensure that the following ports are not blocked:<ul data-bbox="391 388 752 527" style="list-style-type: none"><li data-bbox="391 388 694 418">- Registrar: ied.sma.de:9523<li data-bbox="391 427 662 456">- Proxy: ied.sma.de:9523<li data-bbox="391 465 657 494">- Stun: stun.sma.de:3478<li data-bbox="391 503 752 527">- Domain: ied.sma.de (for SIP URI)
10347	<p data-bbox="321 545 694 574">Stun server DNS resolution failed</p> <p data-bbox="321 583 851 612">It is likely that there is an error in the network settings.</p> <p data-bbox="321 621 559 651">Corrective measures:</p> <ul data-bbox="342 659 1029 871" style="list-style-type: none"><li data-bbox="342 659 1029 689">• Check the network components (DLAN, WLAN Access Point etc.).<li data-bbox="342 697 842 871">• Ensure that the following ports are not blocked:<ul data-bbox="391 732 752 871" style="list-style-type: none"><li data-bbox="391 732 694 762">- Registrar: ied.sma.de:9523<li data-bbox="391 770 662 800">- Proxy: ied.sma.de:9523<li data-bbox="391 808 657 838">- Stun: stun.sma.de:3478<li data-bbox="391 847 752 871">- Domain: ied.sma.de (for SIP URI)
10348	<p data-bbox="321 888 935 918">Webconnect error: No reply to request to STUN server</p> <p data-bbox="321 927 851 956">It is likely that there is an error in the network settings.</p> <p data-bbox="321 965 559 994">Corrective measures:</p> <ul data-bbox="342 1003 1029 1218" style="list-style-type: none"><li data-bbox="342 1003 1029 1032">• Check the network components (DLAN, WLAN Access Point etc.).<li data-bbox="342 1041 842 1218">• Ensure that the following ports are not blocked:<ul data-bbox="391 1076 752 1218" style="list-style-type: none"><li data-bbox="391 1076 694 1105">- Registrar: ied.sma.de:9523<li data-bbox="391 1114 662 1144">- Proxy: ied.sma.de:9523<li data-bbox="391 1152 657 1182">- Stun: stun.sma.de:3478<li data-bbox="391 1190 752 1218">- Domain: ied.sma.de (for SIP URI)

Event number	Message, cause and corrective measures
10349	<p data-bbox="321 199 859 227">Webconnect error: No reply to SIP option packs</p> <p data-bbox="321 239 1106 296">It is likely that there is an error in the network settings or a Sunny Portal maintenance message is present.</p> <p data-bbox="321 309 558 336">Corrective measures:</p> <ul data-bbox="342 348 1029 626" style="list-style-type: none"> <li data-bbox="342 348 1005 406">• If a Sunny Portal maintenance message is present, wait until the maintenance has been completed. <li data-bbox="342 418 1029 446">• Check the network components (DLAN, WLAN Access Point etc.). <li data-bbox="342 458 842 626">• Ensure that the following ports are not blocked: <ul style="list-style-type: none"> <li data-bbox="391 493 694 520">- Registrar: ied.sma.de:9523 <li data-bbox="391 532 662 560">- Proxy: ied.sma.de:9523 <li data-bbox="391 572 657 600">- Stun: stun.sma.de:3478 <li data-bbox="391 612 749 640">- Domain: ied.sma.de (for SIP URI)
10350	<p data-bbox="321 644 949 671">Webconnect error: Registration rejected by SIP registrar</p> <p data-bbox="321 683 851 711">It is likely that there is an error in the network settings.</p> <p data-bbox="321 723 558 751">Corrective measures:</p> <ul data-bbox="342 763 1029 973" style="list-style-type: none"> <li data-bbox="342 763 1029 791">• Check the network components (DLAN, WLAN Access Point etc.). <li data-bbox="342 803 842 973">• Ensure that the following ports are not blocked: <ul style="list-style-type: none"> <li data-bbox="391 838 694 866">- Registrar: ied.sma.de:9523 <li data-bbox="391 878 662 906">- Proxy: ied.sma.de:9523 <li data-bbox="391 918 657 946">- Stun: stun.sma.de:3478 <li data-bbox="391 958 749 986">- Domain: ied.sma.de (for SIP URI)
10351	<p data-bbox="321 991 567 1019">Unknown SIP registry</p> <p data-bbox="321 1031 851 1058">It is likely that there is an error in the network settings.</p> <p data-bbox="321 1071 558 1098">Corrective measures:</p> <ul data-bbox="342 1111 1029 1321" style="list-style-type: none"> <li data-bbox="342 1111 1029 1138">• Check the network components (DLAN, WLAN Access Point etc.). <li data-bbox="342 1150 842 1321">• Ensure that the following ports are not blocked: <ul style="list-style-type: none"> <li data-bbox="391 1185 694 1213">- Registrar: ied.sma.de:9523 <li data-bbox="391 1225 662 1253">- Proxy: ied.sma.de:9523 <li data-bbox="391 1265 657 1293">- Stun: stun.sma.de:3478 <li data-bbox="391 1305 749 1333">- Domain: ied.sma.de (for SIP URI)

Event number	Message, cause and corrective measures
10352	<p>Webconnect error: Faulty communication</p> <p>It is likely that there is an error in the network settings or a Sunny Portal maintenance message is present.</p> <p>Corrective measures:</p> <ul style="list-style-type: none"> • If a Sunny Portal maintenance message is present, wait until the maintenance has been completed. • Check the network components (DLAN, WLAN Access Point etc.). • Ensure that the following ports are not blocked: <ul style="list-style-type: none"> - Registrar: ied.sma.de:9523 - Proxy: ied.sma.de:9523 - Stun: stun.sma.de:3478 - Domain: ied.sma.de (for SIP URI)
10353	<p>Webconnect error: registration of the SIP registry has not responded</p> <p>It is likely that there is an error in the network settings or a Sunny Portal maintenance message is present.</p> <p>Corrective measures:</p> <ul style="list-style-type: none"> • If a Sunny Portal maintenance message is present, wait until the maintenance has been completed. • Check the network components (DLAN, WLAN Access Point etc.). • Ensure that the following ports are not blocked: <ul style="list-style-type: none"> - Registrar: ied.sma.de:9523 - Proxy: ied.sma.de:9523 - Stun: stun.sma.de:3478 - Domain: ied.sma.de (for SIP URI)
27107	<p>Update file OK</p> <p>The update file is suitable for this inverter and its components and is fully available for the next update step.</p>
27108	<p>Memory card is being read</p> <p>The storage medium is being read.</p>
27109	<p>No new update on the memory card</p> <p>A new update file was not found on the storage medium.</p>
27301	<p>Update communication</p> <p>The inverter is updating the communication component.</p>
27302	<p>Update main CPU</p> <p>The inverter is updating the inverter component.</p>
27312	<p>Update completed</p> <p>The inverter has successfully completed the update.</p>

Event number	Message, cause and corrective measures
27331	Update transport started The inverter has successfully started the update.
27332	Update transport successful The update file has been successfully transferred to the communication component.
29001	Inst. code valid The entered Grid Guard code is valid. Protected parameters have now been unlocked and you can adjust the parameters. The parameters will be automatically locked again after ten feed-in hours.
29004	Grid parameters unchanged Changing the grid parameters is not possible.

6.3 Checking the PV System for Ground Faults

QUALIFIED PERSON

If the inverter displays the event numbers **3501**, **3601** or **3701**, there could be a ground fault. The electrical insulation from the PV system to ground is defective or insufficient.

DANGER

Danger to life due to electric shock when touching live system components in case of a ground fault

If a ground fault occurs, parts of the system may still be live. Touching live parts and cables results in death or lethal injuries due to electric shock.

- Disconnect the product from voltage sources and make sure it cannot be reconnected before working on the device.
- Touch the cables of the PV array on the insulation only.
- Do not touch any parts of the substructure or frame of the PV array.
- Do not connect PV strings with ground faults to the inverter.
- Ensure that no voltage is present and wait five minutes before touching any parts of the PV system or the product.

NOTICE

Destruction of the measuring device due to overvoltage

- Only use measuring devices with a DC input voltage range of 600 V or higher.

Procedure:

In order to check the PV system for ground faults, perform the following actions in the prescribed order. The exact procedure is described in the following sections.

- Check the PV system for ground faults by measuring the voltage.

- If the voltage measurement was not successful, check the PV system via insulation resistance measurement for ground faults.

Test by Measuring the Voltage

Proceed as follows to check each string in the PV system for ground faults.

Procedure:

1.

 **DANGER**

Danger to life due to high voltages

- Disconnect the inverter from any voltage sources (see the inverter installation manual).

2. Measure the voltages:

- Measure the voltage between the positive terminal and the ground potential (PE).
- Measure the voltage between the negative terminal and the ground potential (PE).
- Measure the voltage between the positive and negative terminals.

If the following results are present at the same time, there is a ground fault in the PV system:

- All measured voltages are stable.
- The sum of the two voltages to ground potential is approximately equal to the voltage between the positive and negative terminals.

3. If a ground fault is present, determine the location of the ground fault via the ratio of the two measured voltages and eliminate the ground fault.
4. If a definite ground fault cannot be measured and the message is still displayed, measure the insulation resistance.
5. Reconnect the strings without ground faults to the inverter and recommission the inverter (see inverter installation inverter).

Location of the ground fault

The example shows a ground fault between the second and third PV module.

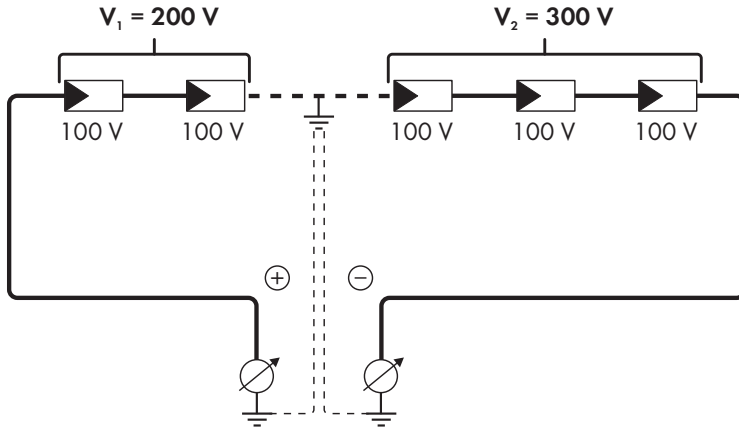

Test by Measuring the Insulation Resistance

If the voltage measurement does not provide sufficient evidence of a ground fault, the insulation resistance measurement can provide more exact results.

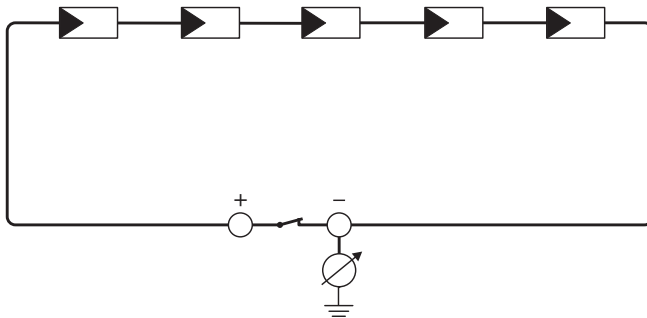

Figure 4: Schematic diagram of the measurement

i Calculating the insulation resistance

The expected total resistance of the PV system or of an individual string can be calculated using the following formula:

$$\frac{1}{R_{\text{total}}} = \frac{1}{R_1} + \frac{1}{R_2} + \frac{1}{R_3} + \dots$$

The exact insulation resistance of a PV module can be obtained from the module manufacturer or the datasheet.

For the resistance of a PV module an average value can be assumed: for thin-film PV modules approximately 40 MOhm and for polycrystalline and monocrystalline PV modules approximately 50 MOhm per PV module (for further information on calculating the insulation resistance see the Technical Information "Insulation Resistance (Riso) of Non-Galvanically Isolated PV Systems" at www.SMA-Solar.com).

Required devices:

- Suitable device for safe disconnection and short-circuiting
- Measuring device for insulation resistance

i Device required for safe disconnection and short-circuiting of the PV array

The insulation resistance can only be measured with a suitable device for safe disconnection and short-circuiting of the PV array. If no suitable device is available, the insulation measurement must not be carried out.

Procedure:

1. Calculate the expected insulation resistance per string.

2.

! DANGER

Danger to life due to high voltages

- Disconnect the inverter from any voltage sources (see the inverter installation manual).

3. Install the short circuit device.
4. Connect the measuring device for insulation resistance.
5. Short-circuit the first string.
6. Set the test voltage. The test voltage should be as close as possible to the maximum system voltage of the PV modules but must not exceed it (see datasheet of the PV modules).
7. Measure the insulation resistance.
8. Eliminate the short circuit.
9. Measure the remaining strings in the same manner.
 - If the insulation resistance of a string deviates considerably from the theoretically calculated value, there is a ground fault present in that string.
10. Reconnect to the inverter only those strings from which the ground fault has been eliminated.
11. Reconnect all other strings to the inverter.

12. Recommission the inverter (see inverter installation manual).
13. If the inverter still displays an insulation error, contact the Service (see Section 9, page 72).
The PV modules might not be suitable for the inverter in the present quantity.

6.4 Resetting the Operation Inhibition after Detection of an Arc Fault

QUALIFIED PERSON

If the red LED is glowing and the event number **4301** is shown on the display and/or in the event list on the user interface of the inverter, the inverter has detected an electric arc and interrupts feed-in operation.

There are two options for resetting the operation inhibition:

- Reset the operation inhibition by tapping twice on the enclosure lid of the Connection Unit.
- Reset the operation inhibition by parameter setting.

Reset the operation inhibition by tapping twice on the enclosure lid of the Connection Unit

1.

DANGER

Danger to life due to electric shock

- Disconnect the inverter from any voltage sources (see the inverter installation manual).

2. Ensure that the PV modules, the connected DC cables and the terminal block for the DC connection are not defective.
Repair or replace defective PV modules, DC cables or terminal block for the DC connection.
 3. Recommission the inverter (see inverter installation manual).
 4. If the event with the event number **4301** appears in the display, immediately tap on the enclosure lid twice in quick succession. Here, the operation inhibition can only be reset if the event is showing in the display when you begin tapping.
- This effects resetting of the operation inhibition and the inverter will start feeding in again. At the same time, the blue LED can flash rapidly, indicating that there is an active WPS function. The WPS function deactivates automatically after a short period.

Reset the operation inhibition by parameter setting

1.

DANGER

Danger to life due to electric shock

- Disconnect the inverter from any voltage sources (see the inverter installation manual).

2. Ensure that the PV modules, the connected DC cables and the terminal block for the DC connection are not defective.
Repair or replace defective PV modules, DC cables or terminal block for the DC connection.
3. Recommission the inverter (see inverter installation manual).
4. Activate the user interface (see Section 4.2, page 22).

5. Log into the user interface as an **Installer** (see Section 4.3, page 26).
 6. Reset the operation inhibition by setting one of the following parameters:
 - Select the parameter **Reset operating data** and set to **Reset operation inhibition**.
 - or**
 - Select the parameter **AFCI switched on** and set to **No** and then back to **Yes**.
- This effects resetting of the operation inhibition and the inverter will start feeding in again.

7 Accessories

You will find the accessories for your product in the following overview. If required, these can be ordered from SMA Solar Technology AG or your distributor.

Designation	Short designation	SMA order number
SMA Antenna Extension Kit	Accessory set for one SMA inverter for the optimization of the SMA inverter's WLAN radio range.	EXTANT-US-40
SMA Sensor Module	Interface for one SMA inverter as retrofit kit for capturing environmental data (e.g. solar irradiation, ambient temperature, cell temperature, wind speed or SO meters).	MD.SEN-US-40
SMA 485 Module	Only for inverters of type "SBx.x-1SP-US-40": for establishing communication between the inverter and the energy meter of the SMA Revenue Grade Meter Kit (only applicable if no SMA Cellular Modem Kit is used)	MD.485-US-40
SMA Cellular LTE Modem Kit	Only for inverters of type "SBx.x-1SP-US-40": for establishing communication with the Sunny Portal via the mobile communication network (as an alternative to Ethernet or WLAN) For establishing communication between the inverter and the energy meter of the Revenue Grade Meter Kit	CellModKit-US-10
SMA Revenue Grade Meter Kit	Only for inverters of type "SBx.x-1SP-US-40": for the installation of an energy meter according to ANSI C12.20	RGM05Kit-US-10

8 Compliance Information

FCC Compliance

This device complies with Part 15 of the FCC Rules and with Industry Canada licence-exempt RSS standard(s).

Operation is subject to the following two conditions:

1. this device may not cause harmful interference, and
2. this device must accept any interference received, including interference that may cause undesired operation.

Le présent appareil est conforme aux CNR d'Industrie Canada applicables aux appareils radio exempts de licence.

L'exploitation est autorisée aux deux conditions suivantes :

1. l'appareil ne doit pas produire de brouillage, et
2. l'utilisateur de l'appareil doit accepter tout brouillage radioélectrique subi, même si le brouillage est susceptible d'en compromettre le fonctionnement.

NOTE: This equipment has been tested and found to comply with the limits for a Class B digital device, pursuant to Part 15 of the FCC Rules. These limits are designed to provide reasonable protection against harmful interference in a residential installation. This equipment generates, uses and can radiate radio frequency energy and, if not installed and used in accordance with the instructions, may cause harmful interference to radio communications. However, there is no guarantee that interference will not occur in a particular installation. If this equipment does cause harmful interference to radio or television reception, which can be determined by turning the equipment off and on, the user is encouraged to try to correct the interference by one or more of the following measures:

- Reorient or relocate the receiving antenna.
- Increase the separation between the equipment and receiver.
- Connect the equipment into an outlet on a circuit different from that to which the receiver is connected.
- Consult the dealer or an experienced radio/TV technician for help.

Changes or modifications made to this equipment not expressly approved by SMA Solar Technology AG may void the FCC authorization to operate this equipment.

IC Compliance

This Class B digital apparatus complies with Canadian ICES-003.

Cet appareil numérique de la classe B est conforme à la norme NMB-003 du Canada.

9 Contact

If you have technical problems with our products, please contact the SMA Service Line. The following data is required in order to provide you with the necessary assistance:

- Device type
- Serial number
- Firmware version
- Event message
- Mounting location and mounting height
- Type and number of PV modules
- Optional equipment, e.g. communication products
- Use the name of the system in Sunny Portal (if available)
- Access data for Sunny Portal (if available)
- Special country-specific settings (if available)
- Operating mode of the multifunction relay

United States	SMA Solar Technology America LLC Rocklin, CA	Toll free for USA and US Territories +1 877-MY-SMATech (+1 877-697-6283) International: +1 916 625-0870
Canada	SMA Solar Technology Canada Inc. Mississauga	Toll free for Canada / Sans frais pour le Canada : +1 877-MY-SMATech (+1 877-697-6283)
México	SMA Solar Technology de México Mexico City	Internacional: +1 916 625-0870

