

Tile Replacement Mount

For use with Flat, S, & W shaped tiles



Installation Instructions

Quick Mount PV[®]
RESPECT THE ROOF

Instructions: QMTR - Tile Replacement Mount

Installation Tools Required: stud finder, tape measure, utility knife, drill with 1/8" bit, impact gun with T-30 Torx bit, channel lock pliers, caulking gun, appropriate sealant compatible with EPDM rubber and roofing materials, roofing bar, hand broom, stapler, 18" wide piece of underlayment or materials for 3-course method.

NOTE: Installation method is the same for all tile replacement flashing profiles.

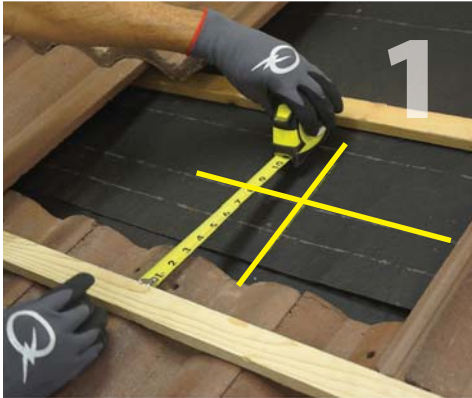

1
Locate and remove the tile that will be replaced by the tile replacement flashing. Remove tile to the left of and above the mount location. Locate rafter and mark center. Measure 8 3/4" up from bottom of the adjacent tiles and mark the location with a horizontal line across rafter.



2
Align the base plate over rafter so the lag holes line up with the rafter line and horizontal line aligns with the post groove. The orientation of the base plate can be flipped east-west for post location versatility of up to 12 1/4". Mark location of lag holes on the roof.



3
Drill two pilot holes using 1/8" bit to a depth of 2 3/4". Be sure lags go into center of rafter for strongest attachment. Pilot holes reduce rafter splitting.



4
Flashing must be waterproofed using 3-course method (see pg 2) or lapped paper method. Use an additional piece of underlayment to slide under the course above as necessary and slide flashing under overlap. Overlap must align with bottom of the flashing. Cut away underlayment so only base plate is exposed.



5
Fill pilot holes with appropriate sealant and align lag holes over the pilot holes. An additional upside down U-shape bead of sealant may be applied to the backside of the flashing. Tuck flashing up under the lapped underlayment if using this method.



6
Use T-30 Torx bit and impact gun to secure mount into rafter with provided hardware.



7
Insert the grade-8 serrated flange bolt into the bottom of the post. Slide post into base plate channel. Line up post with the hole in the tile replacement flashing. Leave loose for adjustments.



8
Place the tile replacement flashing over the post and mount, allowing flashing to interlock with surrounding tiles properly. Secure the post by tightening it down using a pair of channel lock pliers. Replace surrounding tiles.



9
Apply a bead of sealant where the post meets the flashing. Slip the EPDM collar over the post and onto the flashing.

Waterproofing on Tile: Three-Course Method

Installation Tools Required: gloves, hammer, brush, roofing cement, trowel, 4 inch wide roof repair fabric.



Gather materials needed.



Apply a bead of sealant in the shape of an upside down U on the back side of the base mount around the lag holes. Bottom of U should point towards roof ridge



Install the base mount. Clean away dust and debris. (See instructions on pg 1)



Apply $\frac{1}{8}$ " thick layer of roofing cement around the top and sides of the sub-flashing with at least 2" extending past the sides of the flashing onto the felt.



While cement is still wet apply 3 pieces of roof repair fabric strips where felt paper and flashing meet – a 16" strip along the top, and a 9½" strip along each side.



After first layer of cement is dry, apply second layer over fabric to finish waterproofing of sub-flashing.

WARNING: Quick Mount PV products are NOT designed and should NOT be used for anchoring fall protection equipment.

ITEM NO.	DESCRIPTION	QTY.
1	FLASHING, .040" X 12' X 7.5", SHEET, 5052-H32, MILL	1
2	TILE REPLACEMENT BASE, 8.125", 6061-T6, MILL	1
3	WASHER, SEALING, 5/16" ID X 3/4" OD, EPDM BONDED SS	2
4	LAG SCREW, GRK RSS WASHER HEAD, 5/16" X 4", T-30, STEEL, CLIMATEK COATED	2

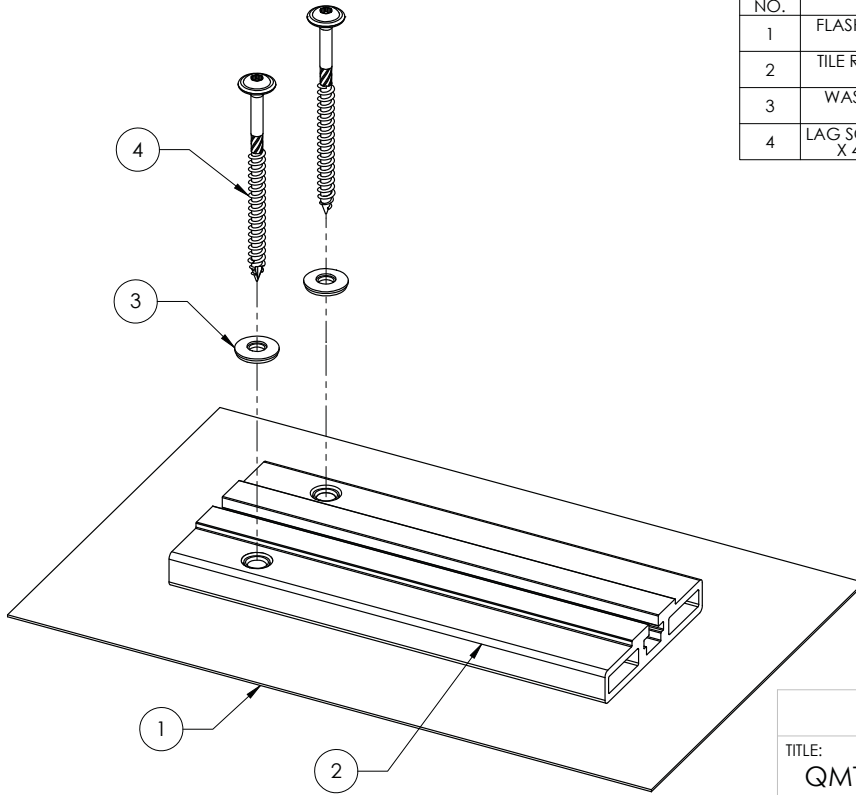

Quick Mount PV®

TITLE:
**QMTR-BM: TILE REPLACEMENT,
BASE MOUNT**

UNLESS OTHERWISE SPECIFIED: DIMENSIONS ARE IN INCHES TOLERANCES: FRACTIONAL ± 1/8 TWO PLACE DECIMAL ±.18 THREE PLACE DECIMAL ±.125	SIZE	DRAWN BY: DFM	REV
	A	DATE: 4/26/2016	1
	SCALE: 1:2	WEIGHT: 2.07	SHEET 1 OF 2

PROPRIETARY AND CONFIDENTIAL
THE INFORMATION CONTAINED IN THIS DRAWING IS THE SOLE PROPERTY OF QUICK MOUNT PV. ANY REPRODUCTION IN PART OR AS A WHOLE WITHOUT THE WRITTEN PERMISSION OF QUICK MOUNT PV IS PROHIBITED.

DO NOT SCALE DRAWING

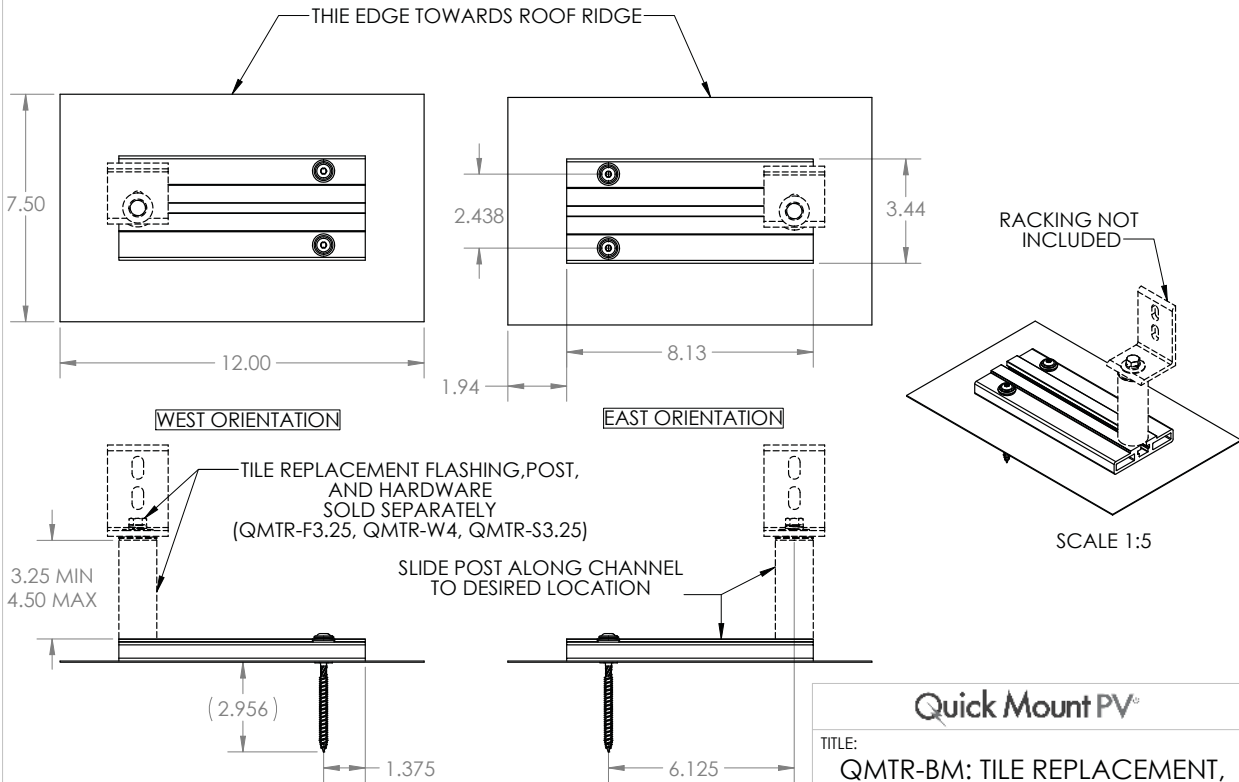

Quick Mount PV®

TITLE:
**QMTR-BM: TILE REPLACEMENT,
BASE MOUNT**

UNLESS OTHERWISE SPECIFIED: DIMENSIONS ARE IN INCHES TOLERANCES: FRACTIONAL ± 1/8 TWO PLACE DECIMAL ±.18 THREE PLACE DECIMAL ±.125	SIZE	DRAWN BY: DFM	REV
	A	DATE: 4/26/2016	1
	SCALE: 1:4	WEIGHT: 2.07	SHEET 2 OF 2

PROPRIETARY AND CONFIDENTIAL
THE INFORMATION CONTAINED IN THIS DRAWING IS THE SOLE PROPERTY OF QUICK MOUNT PV. ANY REPRODUCTION IN PART OR AS A WHOLE WITHOUT THE WRITTEN PERMISSION OF QUICK MOUNT PV IS PROHIBITED.

DO NOT SCALE DRAWING

ITEM NO.	DESCRIPTION	QTY.
1	CAP SCREW, SERRATED FLANGE, HEX HEAD, 5/16"-18 X 1" UNC-2A, GRADE 8, ZINC	1
2	POST, 1-1/4" OD X 3-1/4", 6063-T5/6063-T6, MILL	1
3	WASHER, SEALING, 5/16" ID X 1-1/4" OD, EPDM BONDED SS	1
4	FLASHING, REPLACEMENT TILE, FLAT, 1" CONE, 6061-O, MILL	1
5	COLLAR, COUNTER FLASHING, 1-1/4" ID EPDM	1
6	WASHER, FENDER, 5/16" ID X 1" OD, 18-8 SS	1
7	WASHER, SPLIT-LOCK, 5/16" ID, 18-8 SS	1
8	CAP SCREW, HEX HEAD, 5/16"-18 X 1" UNC-2A, 18-8 SS	1

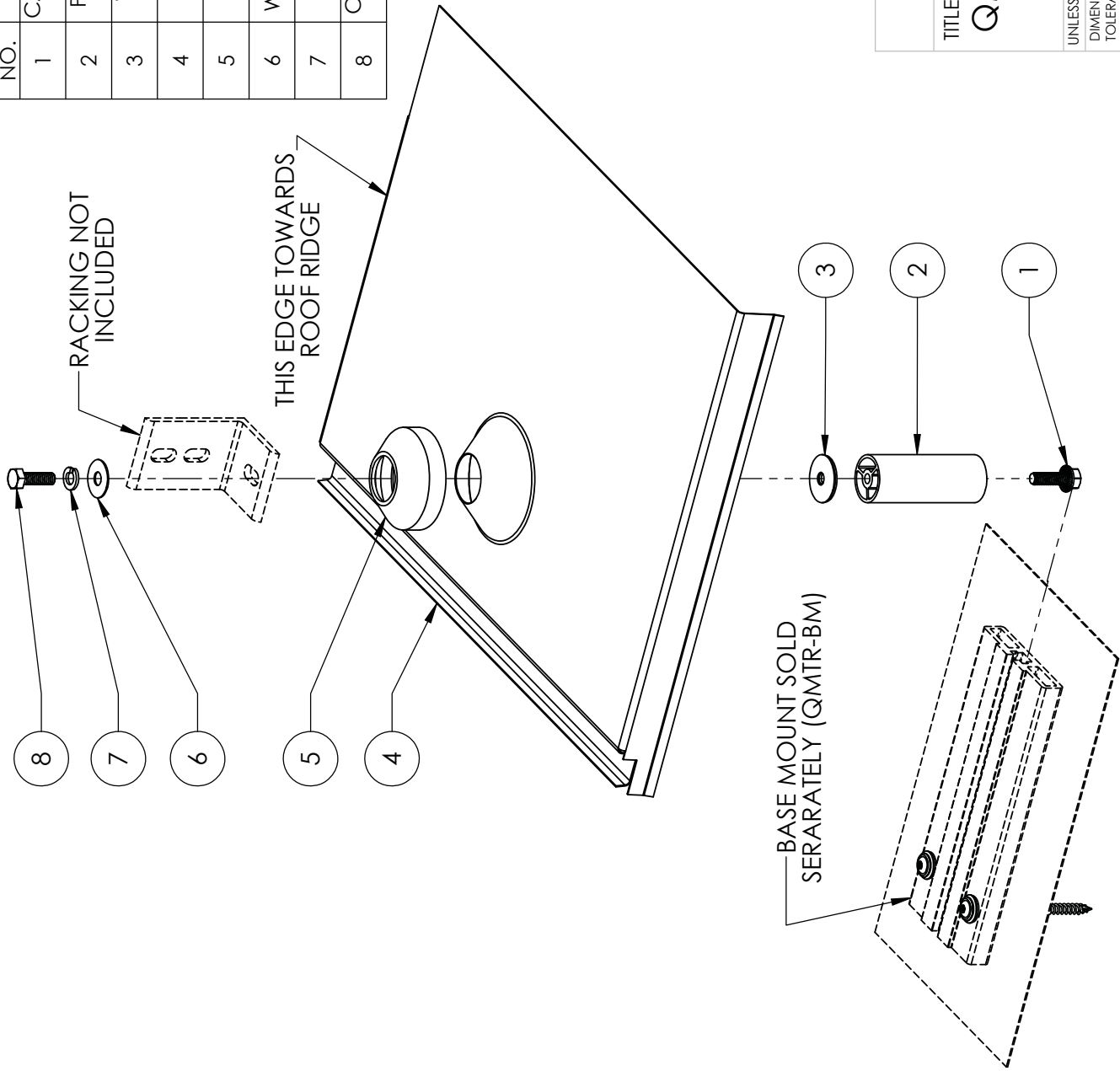

Quick Mount PV[®]

TITLE:

**QMTR-F3.25: TILE REPLACEMENT,
FLAT TILE, 3-1/4" POST**

UNLESS OTHERWISE SPECIFIED:
DIMENSIONS ARE IN INCHES
TOLERANCES:
FRACTIONAL ± 1/8
TWO PLACE DECIMAL ±.18
THREE PLACE DECIMAL ±.125

SIZE	DRAWN BY:	DFM	REV
A	DATE:	5/12/2016	1
SCALE: 1:4		WEIGHT: 2.85	SHEET 1 OF 1

DO NOT SCALE DRAWING

PROPRIETARY AND CONFIDENTIAL
THE INFORMATION CONTAINED IN THIS DRAWING IS THE SOLE PROPERTY OF QUICK MOUNT PV. ANY REPRODUCTION IN PART OR AS A WHOLE WITHOUT THE WRITTEN PERMISSION OF QUICK MOUNT PV IS PROHIBITED.

ITEM NO.	DESCRIPTION	QTY.
1	CAP SCREW, SERRATED FLANGE, HEX HEAD, 5/16"-18 X 1" UNC-2A, GRADE 8, ZINC	1
2	POST, 1.25" OD X 4", 6063-T5/6063-T6, MILL	1
3	WASHER, SEALING, 5/16" ID X 1-1/4" OD, EPDM BONDED SS	1
4	FLASHING, REPLACEMENT TILE, W-TILE, .625" CONE, 6061-O, MILL	1
5	COLLAR, COUNTER FLASHING, 1-1/4" ID EPDM	1
6	WASHER, FENDER, 5/16" ID X 1" OD, 18-8 SS	1
7	WASHER, SPLIT-LOCK, 5/16" ID, 18-8 SS	1
8	CAP SCREW, HEX HEAD, 5/16"-18 X 1" UNC-2A, 18-8 SS	1

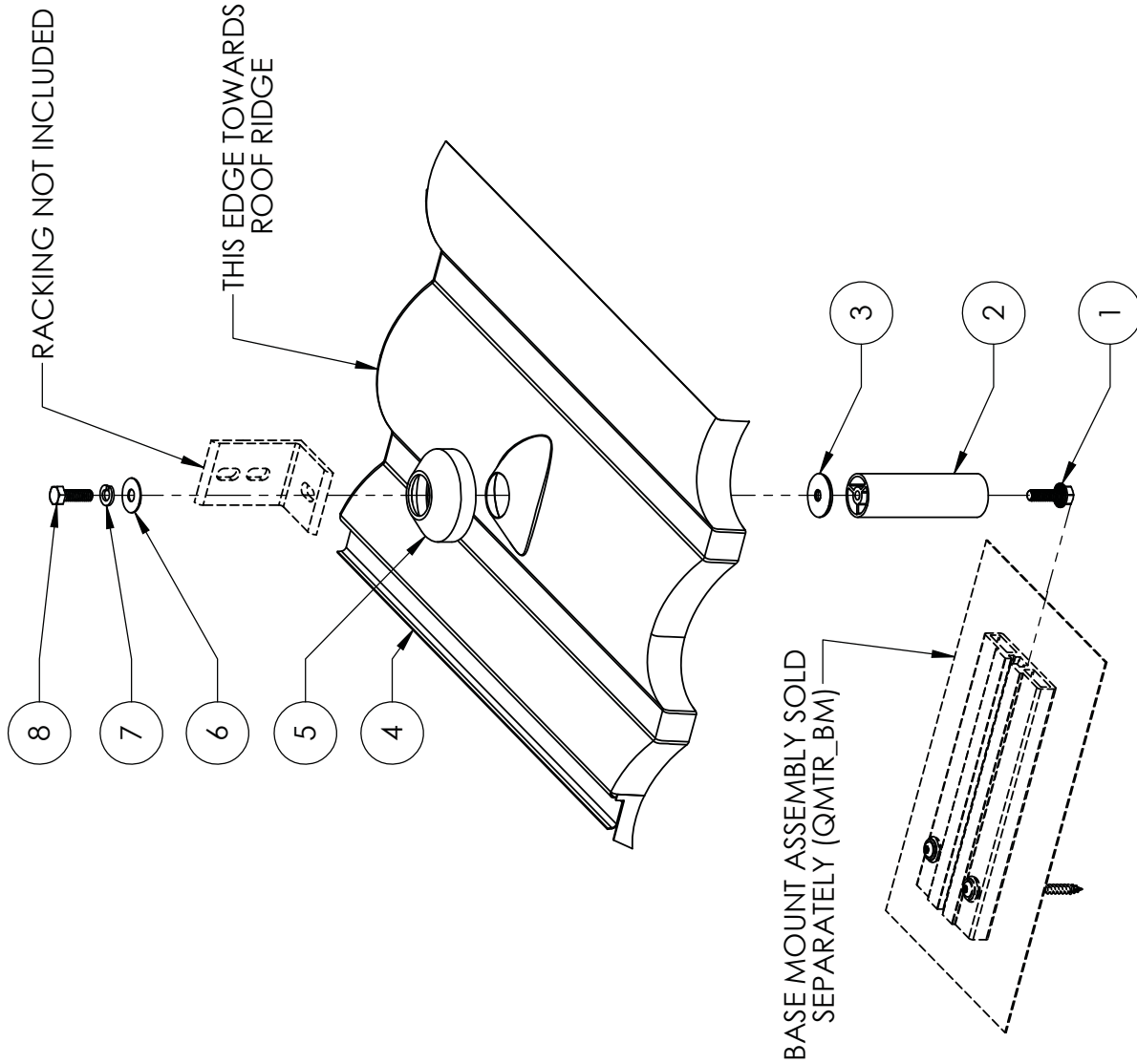

Quick Mount PV[®]

TITLE:

**QMTR-W4: TILE REPLACEMENT,
W-TILE, 4" POST**

UNLESS OTHERWISE SPECIFIED: DIMENSIONS ARE IN INCHES TOLERANCES: FRACTIONAL $\pm 1/8$ TWO PLACE DECIMAL $\pm .18$ THREE PLACE DECIMAL $\pm .125$	SIZE A	DRAWN BY: DFM	REV 1
	SCALE: 1:5	DATE: 5/12/2016	WEIGHT: 2.89
DO NOT SCALE DRAWING			SHEET 1 OF 1

PROPRIETARY AND CONFIDENTIAL
THE INFORMATION CONTAINED IN THIS DRAWING IS THE SOLE PROPERTY OF QUICK MOUNT PV. ANY REPRODUCTION IN PART OR AS A WHOLE WITHOUT THE WRITTEN PERMISSION OF QUICK MOUNT PV IS PROHIBITED.

ITEM NO.	DESCRIPTION	QTY.
1	CAP SCREW, SERRATED FLANGE, HEX HEAD, 5/16"-18 X 1" UNC-2A, GRADE 8, ZINC	1
2	POST, 1-1/4" OD X 3-1/4", 6063-T5/6063-T6, MILL	1
3	WASHER, SEALING, 5/16" ID X 1-1/4" OD, EPDM BONDED SS	1
4	FLASHING, REPLACEMENT TILE, S-TILE, .625" CONE, 6061-O, MILL	1
5	COLLAR, COUNTER FLASHING, 1-1/4" ID EPDM	1
6	WASHER, FENDER, 5/16" ID X 1" OD, 18-8 SS	1
7	WASHER, SPLIT-LOCK, 5/16" ID, 18-8 SS	1
8	CAP SCREW, HEX HEAD, 5/16"-18 X 1" UNC-2A, 18-8 SS	1

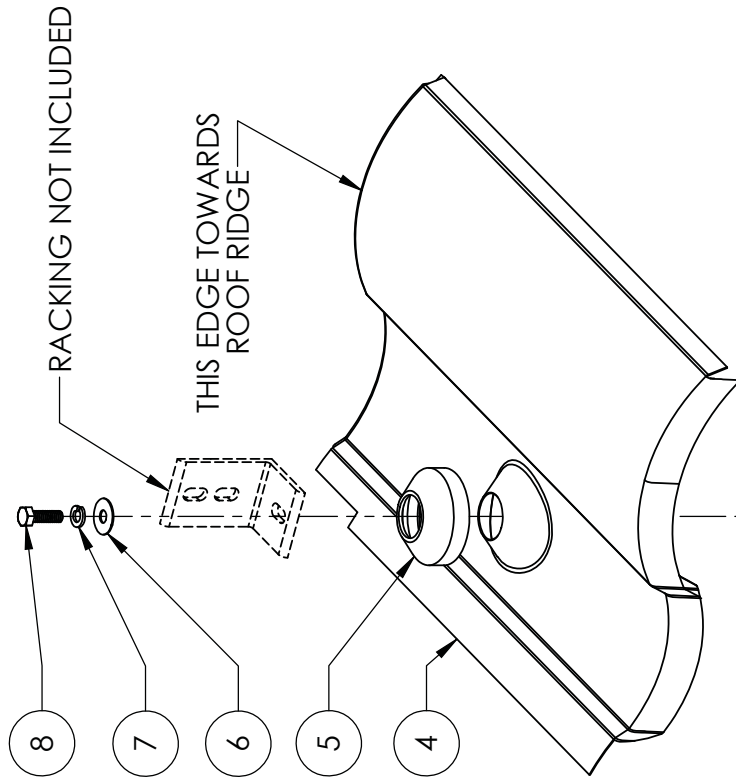

BASE MOUNT ASSEMBLY SOLD SEPARATELY (QMTR_BM)

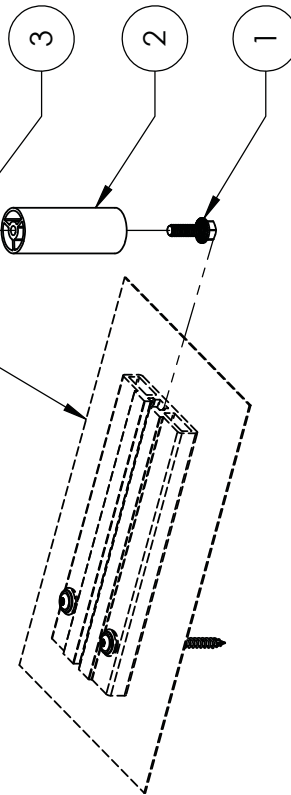

Quick Mount PV[®]

TITLE:

**QMTR-S3.25: TILE REPLACEMENT,
S-TILE, 3-1/4" POST**

UNLESS OTHERWISE SPECIFIED: DIMENSIONS ARE IN INCHES TOLERANCES: FRACTIONAL ± 1/8 TWO PLACE DECIMAL ± .18 THREE PLACE DECIMAL ± .125	SIZE	DRAWN BY:	DFM	REV
	A	DATE:	5/12/2016	1
SCALE: 1:5			WEIGHT: 2.80	SHEET 1 OF 1

DO NOT SCALE DRAWING

PROPRIETARY AND CONFIDENTIAL
THE INFORMATION CONTAINED IN THIS DRAWING IS THE SOLE PROPERTY OF QUICK MOUNT PV. ANY REPRODUCTION IN PART OR AS A WHOLE WITHOUT THE WRITTEN PERMISSION OF QUICK MOUNT PV IS PROHIBITED.



925-478-8269 | www.quickmountpv.com | tech@quickmountpv.com
2700 Mitchell Dr. | Walnut Creek, CA 94598