

**27' FOOT LAND TOWER  
KIT For AIR™ WIND  
MODULE**

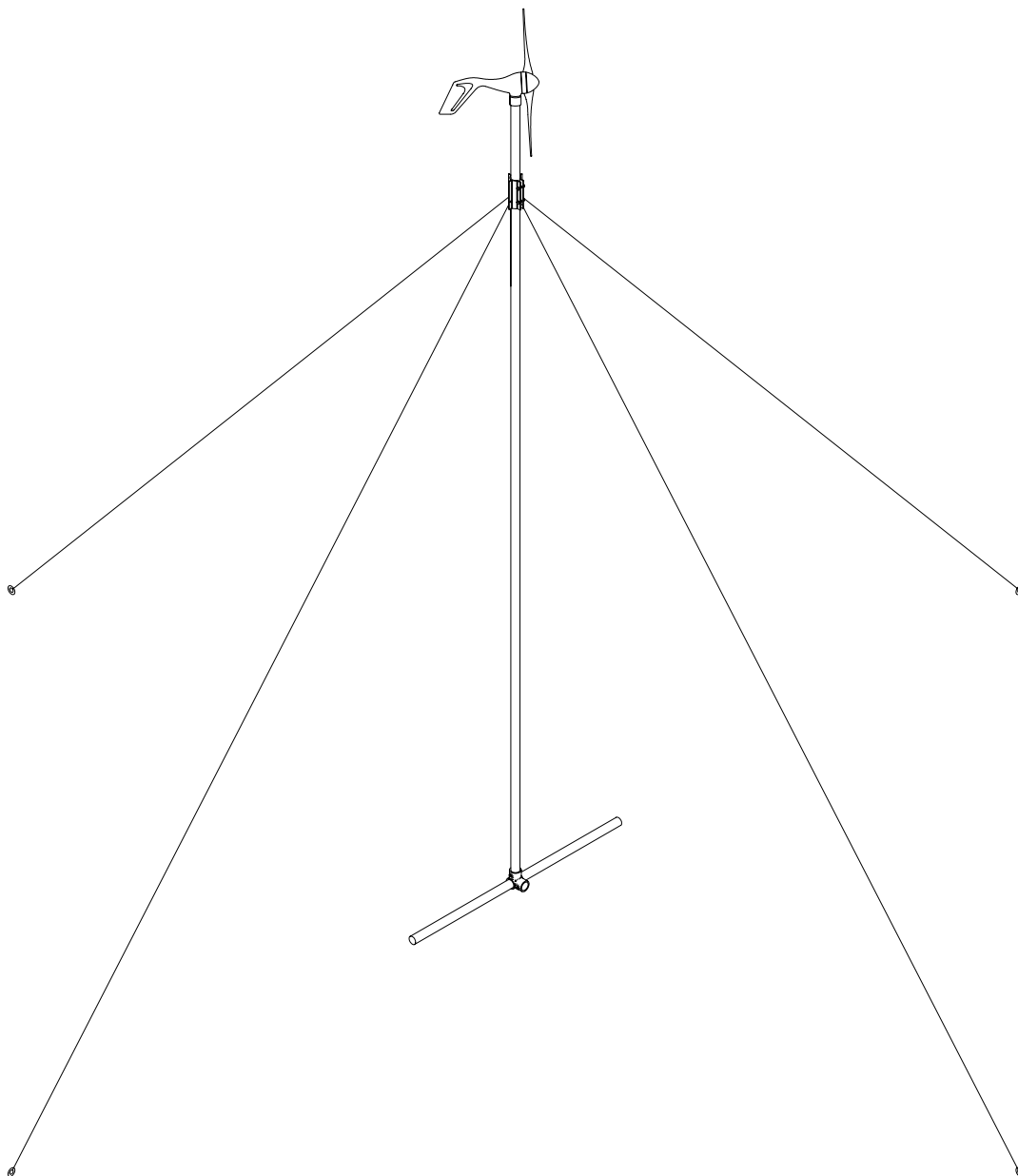

**Made in the USA by:**

***Primus Wind Power***

938 Quail Street  
Lakewood, CO 80215  
(303) 242-5820

***AIR*** is a trademark of  
Primus Wind Power, Inc.

## **27 Foot LAND TOWER KIT**

CONGRATULATIONS! You have just received the simplest, most economical tower kit available for your AIR wind turbine. This kit is designed to be very easy to assemble and erect, however it is important that you read this manual thoroughly before beginning assembly. If you have any questions on proper installation or usage please call either Primus Wind Power or your dealer for more information.

*Notice: This information is believed to be reliable; however, Primus Wind Power assumes no responsibility for inaccuracies or omissions. The user of this information and product assumes full responsibility and risk. All specifications are subject to change without notice.*

<b><u>CONTENTS</u></b>		<b><u>page</u></b>
<b>Introduction</b>		
	<b>Tower Kit Features</b>	<b>3</b>
	<b>Safety</b>	<b>3</b>
	<b>Parts List</b>	<b>4</b>
	<b>Tools Needed</b>	<b>4</b>
<b>Step 1:</b>	<b>Site Selection</b>	<b>5</b>
<b>Step 2:</b>	<b>Mast and Hardware Selection</b>	<b>6</b>
<b>Step 3:</b>	<b>Tower, Base and Anchor Layout</b>	<b>7</b>
<b>Step 4:</b>	<b>Guy Wire Anchor Installation</b>	<b>9</b>
<b>Step 5:</b>	<b>Tower Base Assembly</b>	<b>12</b>
<b>Step 6:</b>	<b>Assembly of Tower and Turbine</b>	<b>12</b>
<b>Step 7:</b>	<b>Attachment of Guy Wires</b>	<b>14</b>
<b>Step 8:</b>	<b>Raising the Tower</b>	<b>16</b>
<b>Step 9:</b>	<b>Adjustment of Guy Wires</b>	<b>16</b>
<b>Step 10:</b>	<b>J-Box and Lightning Arrestor Installation</b>	<b>17</b>

## Introduction

This tower kit is designed specifically for the Primus Wind Power AIR 30 and AIR 40 wind turbines. To our knowledge this is the most economical and user friendly tower kit available for the “AIR” wind turbines. Guy wire supported construction allows the use of lightweight tubing while providing plenty of strength for all but hurricane conditions. Two people can easily erect a tower with this kit in an hour or so. Since the turbine and the tower kit are light in weight, no winches, vehicles or beasts of burden are needed to erect the tower. All that is required is a little bit of “elbow grease”. We recommend that at least two people be present when the tower is raised, although it is conceivable that a single person could actually raise a tower on their own.

The AIR tower kit includes a simple yet effective elbow/tee for its base. Combined with a short length of tubing this type of base eliminates the need for a concrete pad, base plate and a swivel for the base of the tower.

A simple extruded aluminum, coupling clamp allows the use of a wide selection of different kinds of tubing, depending on availability, site requirements and customer preference. Threaded coupling points are eliminated, allowing lighter materials to be used with the same or greater strength than a threaded pipe tower. Pre-cut and swaged guy wires eliminate wire measuring and cutting.

We believe this kit and assembly method is the easiest way possible to put the AIR wind module up in the air. Thank you for purchasing our products and for your interest in renewable energy. We expect that you will enjoy the benefits of your wind powered electrical system for many years to come. If, after reading this manual, you have any further questions please contact your local dealer or Primus Wind Power and we will do our best to assist you.

### Safe Installation

**Safety is the most important consideration to take into account when installing a tower and wind turbine.** It is very important to remember that any wind turbine has high speed spinning parts and can be very dangerous if not installed properly! Be sure that the tubing or pipe used for the tower is of adequate strength, that all bolted connections are tight and that the guy wire anchors are suitable for your soil conditions. All of these elements are explained in further detail later in this manual. **Important! Choose a very calm day to do your installation. A gust of wind at the wrong moment could cause A VERY SERIOUS ACCIDENT!**

**PLEASE....READ ALL OF THIS MANUAL BEFORE DOING ANYTHING !**

### 27 Foot Tower Kit Parts List

<u>Your tower kit includes:</u>	<u>Quantity</u>
Tower Base	1

Wire set	1
Tower Base Staples	2
3/8" x 1 1/2" Bolts	2
3/8" Locknuts	2
Cable Thimbles	4
Cable Clamps	8

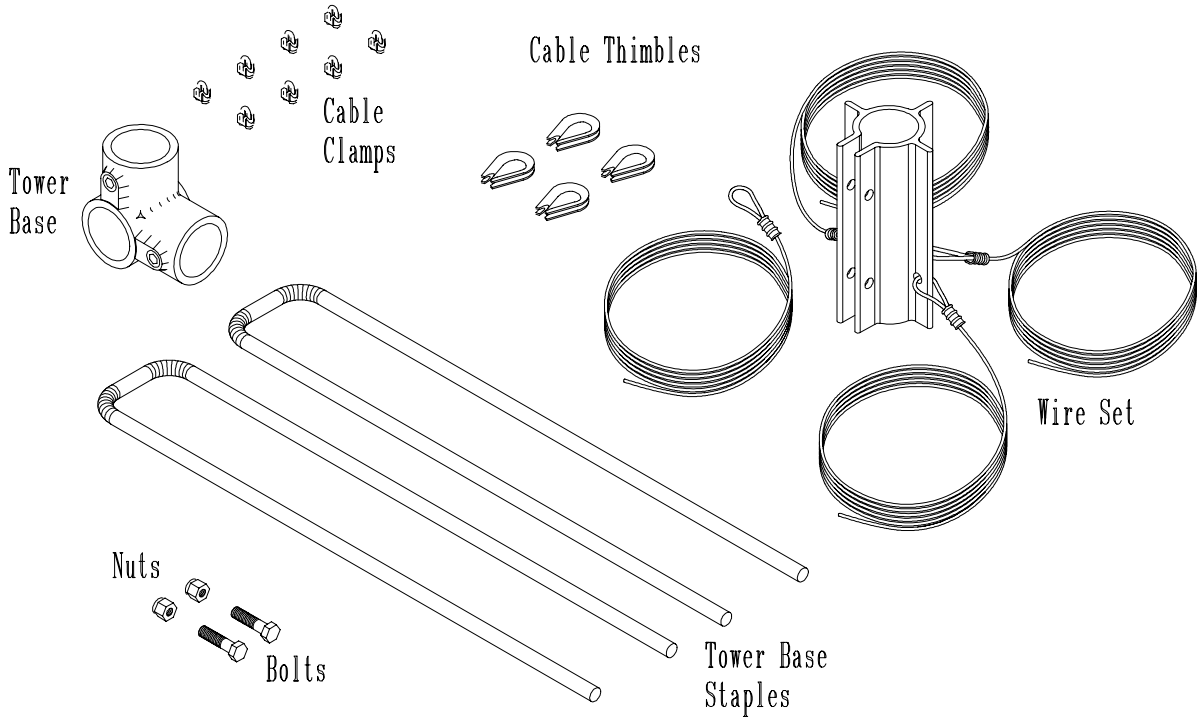

Figure 1 (Parts List)

**Tools Needed:**

- Round or Half Round File
- 5/16" or 8mm Wrench, Socket or Nut Driver (preferred)
- (2) 9/16" or 15mm Wrenches or Sockets
- Sledge Hammer
- Pliers
- Carpenters Level
- 5/16" allen wrench (supplied with turbine)

**Items Not Included In This Kit:**

- Anchors (The type of anchors used will depend on the soil conditions at your tower site. This is explained further in the "Anchors" section of this manual.)
- Ground Rod and Clamp \*
- Lightning Arrestor \*
- Junction Box and Adapter \*
- Flex Conduit and Fitting \*

Electrical Wire

Wire Connectors (preferably copper split bolts)

Pipe Insulation (to prevent wire “rattle” inside pole) \*

Electrical tape

Tubing for the tower (this is explained in Step 2 on page 6)

\* optional items (these are explained in detail in their relevant assembly sections)

## Step 1: Site Selection

### Site selection is the most important factor affecting the performance of your wind turbine!

The energy in the wind is the kinetic energy of the moving air mass. What a wind turbine does is convert some of that kinetic energy into mechanical energy which can then be converted to electricity. The formula for the amount of power in the wind is a cube function of the wind speed. This means basically that an increase in wind speed of 10% (say from 9 mph to 10 mph) will result in approximately a 30% increase in the power available from the wind and a similar difference in turbine performance. In almost all locations the wind speed increases as you get higher off the ground. This is why a tall tower is very important at most wind sites. As a rule, the turbine should be mounted as high in the air and as far away from obstructions as is possible.

To find the best location to erect your tower and wind turbine, study the area available and take note of how the prevailing (most common) winds blow through it. If there are trees, buildings, hills or other obstructions take note of how high they are and where they are in relation to the usual wind direction. The best site for your tower and turbine will be upwind and above any obstructions which may exist. If there are houses or trees in the surrounding area it is best to mount the turbine at least twice as high as any obstruction in the area. If the turbine is to be mounted at the crest of a hill or on a beach where winds come from across the water, a smaller tower may be acceptable.

The next consideration in siting your tower and turbine is the distance from the turbine to your batteries. The shortest distance will require the least amount of wire and reduce the amount of power lost through the wiring. If a long distance is required between your tower and the batteries it will be necessary to use heavy gage wire to reduce the resistance of the wire. The power consumed by the wires can be calculated using the formula:

$$\text{Power} = \text{Current} \times \text{Current} \times \text{Resistance}$$

Since the resistance of the wire is directly proportional to its length, making the run shorter will dramatically reduce the amount of power “lost” in the wires.

The other concern with long wires is the voltage drop through the wire. Voltage drop through the wires can be calculated using the formula:

$$\text{Voltage} = \text{Current} \times \text{Resistance}$$

The effect of the voltage drop is most apparent when the turbine has good wind and is actively charging the batteries. The AIR turbine’s internal voltage regulator senses battery voltage, and will measure the combined voltage drop from the batteries and from the current passing through the resistance of the wires. This causes the turbine to sense a higher voltage than that of the batteries and regulate its power accordingly to prevent overcharging. When this happens the turbine may not fully charge the batteries. Adjusting the regulation set point of the turbine to compensate for this at higher wind speeds can cause the turbine to overcharge the batteries in

lighter wind conditions. If a long distance between the tower and batteries is necessary, using a large wire size will help to address this issue. The person laying out your power system should be aware of these considerations when the system is in the planning stages.

Please refer to the section on “Tower, Base and Anchor Layout”. The amount of space available to assemble and raise the tower may also affect where your tower can be placed.

**Step 2: Mast Tubing and Hardware Selection**

Due to the high cost of shipping and the widespread availability of the tubing or pipe used for our towers these materials are not provided by Primus Wind Power. These materials are readily available through most fence suppliers or plumbing companies and will cost much less when purchased locally than if they were shipped from our factory.

The AIR wind module is designed to be mounted on a 1.875 in. outside diameter pole. This is the same outside diameter as 1 ½ in. steel water pipe where the “1 ½” is a nominal size indicating an outside diameter that is actually 1.875 in.. Whether the pipe is “schedule 20”, or “schedule 40”, the outside diameter will be the same and the schedule number will determine the wall thickness of the pipe. If the pipe is lighter than “schedule 20”, it is referred to as “tubing”, and the actual outside diameter and wall thickness is usually specified.

The design of this tower kit allows pipe (or tubing) of various different wall thickness to be used depending on the severity of the wind at your site location.

Use the following table to determine the acceptable pipe size(s) for your tower and wind severity. In most locations structural steel tubing with a wall thickness of .065 inches is sufficient for the conditions and preferable in terms of cost and ease of assembly. Electrical conduit must be avoided for use in your tower assembly, since it is generally not designed for strength.

Use the following table for Pipe / Tubing wall thickness guidelines:

<u>Maximum Wind Speed</u>	<u>Recommended Wall Thickness</u>	<u>Pipe Schedule</u>
90 mph.	.065 inch (1.65 mm)	“Tubing”
100 mph.	.090 inch ( 2.3 mm)	Schedule 20
120 mph.	.140 inch ( 3.6 mm)	Schedule 40

Although the design of this tower kit will allow different wall thicknesses of pipe to be used in the same tower, we recommend that the same thickness pipe be used for both the upper and lower sections.

Three Pieces Are Needed:

**24 foot** length of pipe for tower (wall thickness selected for local conditions)

**3 foot** length of pipe for tower (wall thickness selected for local conditions)

**6 foot** length of tubing for tower base (.065 in. wall thickness)

*\*\*\*\*In some areas there are subsidies and grants available for installing renewable energy systems. If you live in one of these areas and need an engineering analysis for this tower assembly to satisfy your local authorities please contact us. We have an engineering analysis available for this tower kit.*

### **Step 3: Tower, Base and Anchor Layout**

This tower kit must be erected on a calm day (no wind). The tower base and anchors should be laid out as described in the drawing on page 8. As a time saver, a piece of tape on the 24-foot length of tower pipe can be used as a measuring stick between the tower base and anchor locations.

The tower will be assembled laying on the ground and then tilted up into position.

If the tower is being erected on the side of a hill it will be much easier to raise the tower if it is assembled to the uphill side of the base as it will already be part way up once it is assembled. In this case two opposing anchors should be at the same height on the hill as the tower base, one anchor should be directly uphill and one directly downhill from the tower base.

If the tower is to be erected on flat ground and there is a breeze blowing the tower should be assembled towards the wind if possible, so that the wind may help slightly as the tower is raised rather than working against you. If your tower is on the side of a hill *and* there is a breeze blowing ignore the breeze and assemble the tower on the uphill side.

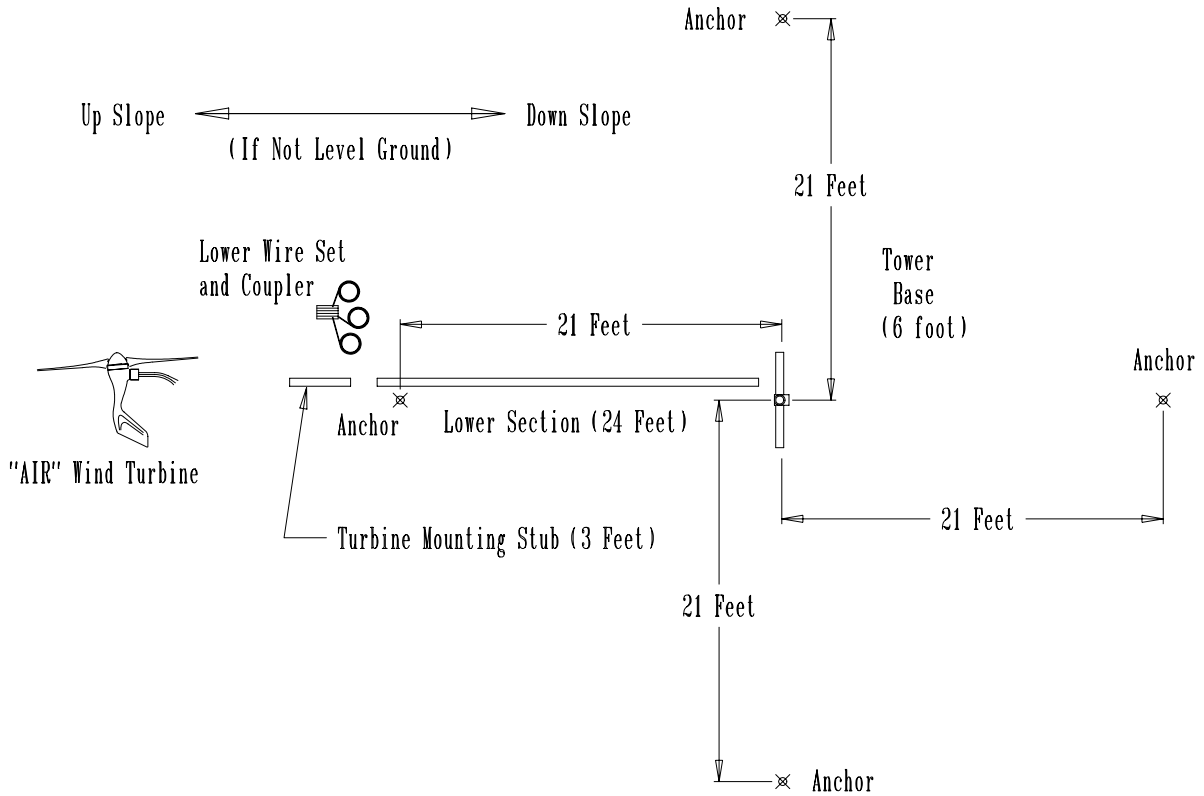

Be sure that the anchor points and base position are in a line when sighted from anchor to anchor. This will insure that the forces on the guy wires are balanced properly, and will make final guy wire adjustments simpler and will help a great deal during the actual raising of the tower. The side anchors and tower base should also be at the same height. If either of these requirements is not met, **the guy wires will either tighten excessively or become excessively slack** as the tower is raised. If the guy wires tighten excessively **the tower may buckle** and collapse, **causing possible injury or even death** and at the very least, damage to both the tower and the turbine. Carefully read the section on raising the tower for further instructions on making the proper adjustments in these situations.



### Step 4: Guy Wire Anchor Installation

There are four types of anchors that are most commonly used with our towers; screw in “Auger” type anchors, hammer driven “Duckbill” anchors, cast concrete anchors and expansion bolts (for use only in solid rock). **What anchor should be used depends on the soil type that the anchors will be placed in.** See the following table for our suggestions:

<u>Soil Type</u>	<u>Recommended Anchor</u>	<u>Alternatives</u>
Sand	Buried Concrete	None
Loose Gravel	Buried Concrete	None
Loam	Auger	Duckbill, Buried Concrete
Clay	Duckbill	Concrete
Rocky Soil	Duckbill	Auger, Buried Concrete
Gravelly Soil	Auger or Duckbill	Buried Concrete
Solid (Soft) Rock	Large, Long Expansion Bolt	Buried Concrete
Solid (Hard) Rock	Smaller Expansion Bolt	Large Eye Bolt + Cement None

**The loads on a single anchor can exceed 500 lb. in a 100-mph gale.** Make sure that the anchors chosen can withstand at least this much force or the tower will have to be lowered during storms. Augers and Duckbill anchors are frequently available at mobile home supply stores. We also sell augers from our factory, however when shipping costs are added they may be more expensive than if they are purchased locally. Expansion bolts for anchoring in solid rock can be purchased at most hardware stores.

**Augers:** If the soil conditions make their use feasible, augers are the simplest anchors to install. Augers screw into the ground by use of a piece of wood, pipe or rod as a “cheater bar”. If a mistake is made or if the tower must be removed an auger can be “unscrewed” out of the ground and reused. Augers depend on the soil holding together for their strength and are not suitable for sand or loose gravel. If the soil is rocky or clay-like you may have difficulty screwing them in.

An auger is usually installed by screwing it straight into the ground a few inches to get it started and then tilting it to the desired angle and continuing. A substantial downward pressure is usually necessary to get an auger started. Screw the augers in as far as possible for the greatest strength.

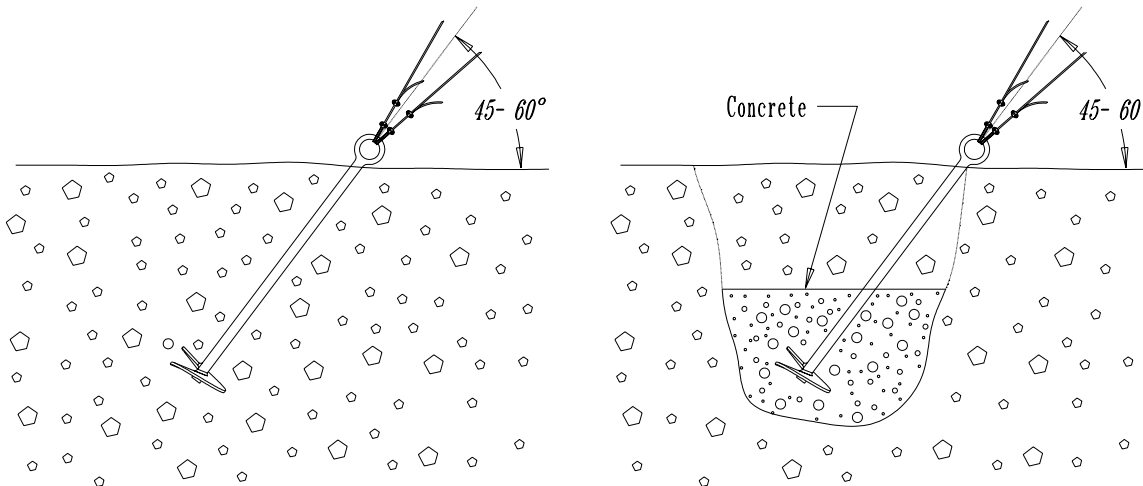

Augers depend on the ability of the soil to hold together for their strength. If augers can not be screwed in, simply digging a hole and burying them will not work. We recommend buying augers, and if they can not be screwed in properly, a hole can be dug and the auger cast in concrete. This will provide a good loop for guy wire attachment and make an excellent anchor in the concrete.

**Duckbill Anchors:** Duckbill anchors consist of an anchor attached to a cable with a loop on the end. They are driven into the ground using an anchor driver, which is a steel rod with either an enlarged striking surface (for a large hammer) or an attachment for a jackhammer or impact driver. The rod fits into the anchor and holds it straight while it is being driven into the ground. Once the anchor is sufficiently deep in the ground, the driver is withdrawn and the anchor cable is pulled a short distance to “set” the anchor. As the anchor is being set it will rotate perpendicular to the hole made as it was driven in, making it very difficult to move any further.

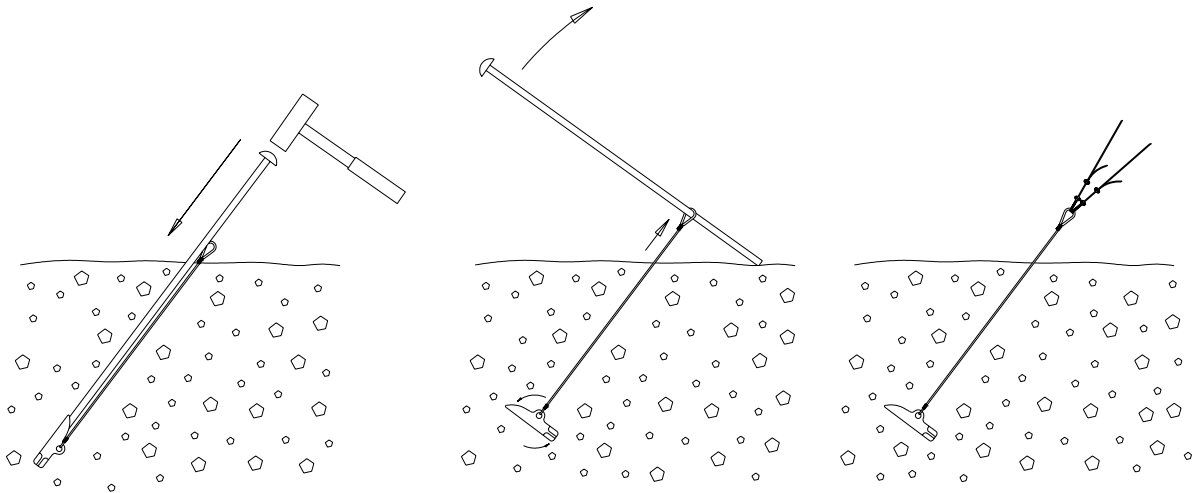

*Please note: Once a duckbill anchor is set in place, it can only be removed by digging it out.*

**Buried Concrete:** A buried concrete anchor may be the only solution if the ground is loose gravel or sand or if it is too rocky for an auger or duckbill to be driven in,. Buried concrete anchors will work in any situation other than solid rock. A hole must be dug in the ground at the desired anchor point. One good tactic is to purchase either augers or duckbills and if they can not be used as intended, then dig holes and cast them in concrete. Otherwise some other means of attachment must be created for the guy wires, such as a loop of steel bar (re-bar) or chain.

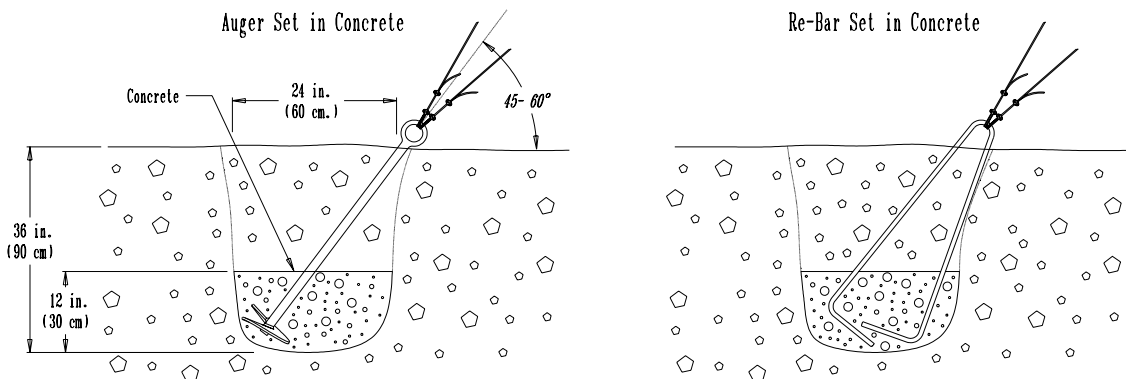

Holes for concrete anchors should be at least 2 feet in diameter and at least 3 feet deep. The attachment should be placed in the hole and concrete or cement poured around it to a depth of at least 1 foot. Once the concrete has set it should be buried before use.

**Anchoring in Rock:** If your tower site has large rocks around it or is located on solid rock, expansion bolts in the rock may be the best means of anchoring your guy wires and base tube. A hole is drilled into the rock and the bolt is placed in the hole with an attachment hanger, a piece of chain or other loop to connect to the guy wires.

For expansion bolts to work properly the rock must be of good quality and not fracture easily. If the rock quality is poor a larger deeper hole can be drilled and a large eye-bolt cemented into it. For very hard rock such as granite and basalt, a 1/4 inch diameter bolt 1 1/2-inch deep can be used. For slightly softer rock such as dacite, welded tufts and some denser varieties of sandstone, a 3/8-inch diameter or larger bolt at least 3 to 4 inches deep can be used.

For softer types of rock, such as sandstone or limestone, a hole 1 inch diameter and 8 inches deep can be drilled and an eye-bolt 5/8 inch in diameter cemented into it. If cement is to be used, it should be mixed just thin enough to pour and poured into the hole before the bolt is installed. This will help to insure that the cement goes to the bottom of the hole and help prevent bubbles that may compromise the strength of the attachment. If expansion bolts are to be used, follow the instructions supplied with the bolts. There are several different types of expansion bolts that are installed using different methods.

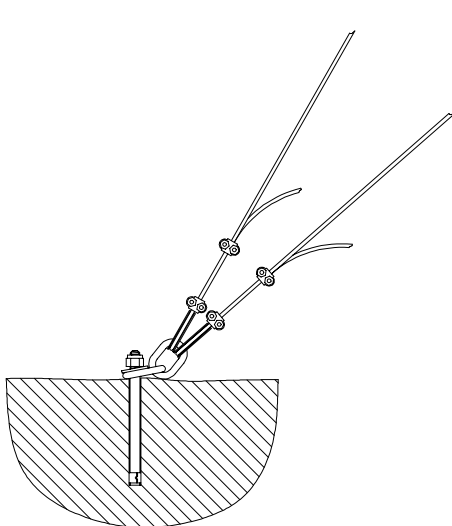

Anchor For Hard Rock

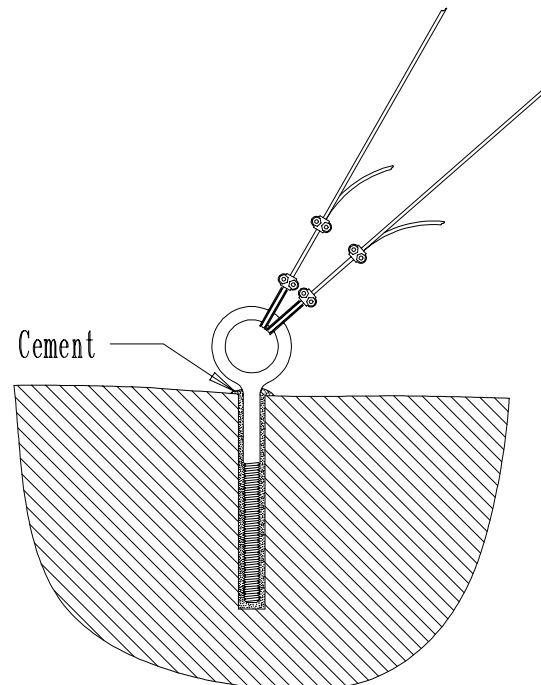

Anchor For Soft Rock

### Step 5: Tower Base Assembly

To assemble the base, a 6 foot long piece of tower tubing is positioned half way through the base tee as shown in the drawing below and the set screw tightened to hold it in position (use the 5/16 inch allen wrench included with your turbine).

The base “T” should now be placed on the position chosen for the base of the tower, perpendicular to the direction that the tower will be raised. Once assembled, the tower will pivot on the base tube as it is raised into position.

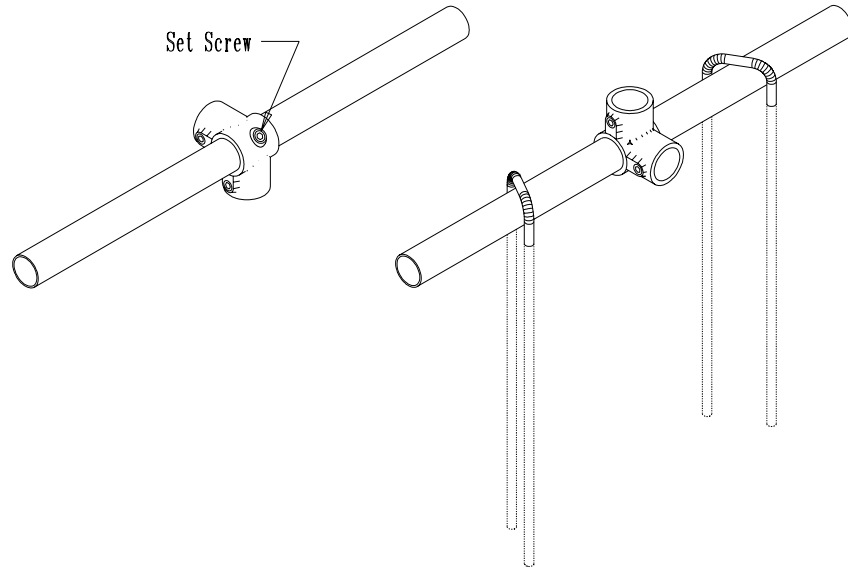

Depending on the nature of the soil at the site, the ground staples (included) should be driven or cemented into the ground so that the base tube is captured. If cement pads are to be used, the base tube can be supported at its ends and used to hold the staples while the cement is setting. If the base is to be on solid hard rock, expansion bolts and chain should be used in place of the staples. For softer rock the staples can be cut shorter and cemented into holes drilled in the rock.

### Step 6: Assembly of Tower and Turbine

*Note: If larger than 6 gauge electrical wire is to be used, it may be necessary to cut or file a relief in the bottom of the lower tower pipe section for increased wire clearance. This should be done before proceeding. Make sure that the inside edge of the tower pipe is smooth and free of burrs that could damage the electrical wires (see figure on page 13).*

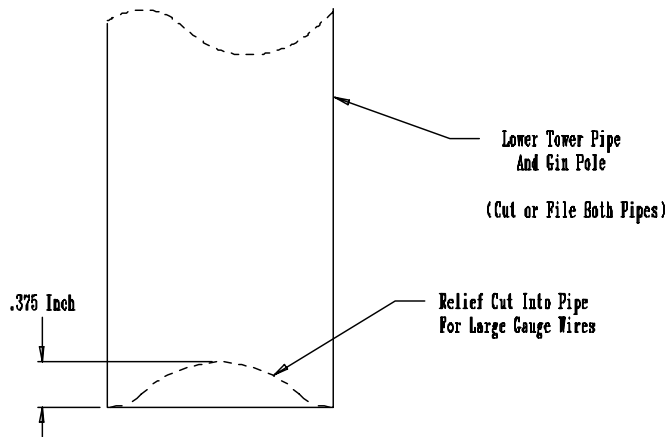

The basic method you will be using to raise the tower will involve assembling the tower on the ground then raising the tower. Assembly of the tower begins as follows:

- 1) The electrical wires for the turbine should be straightened and cut a couple of feet longer than the tower height.
- 2) Trim and strip the ends of the turbine wires so that the wires are staggered about 2 inches (red wire 12 inches, black wire 10 inches, green wire 8 inches).
- 3) Connect the electrical wires to the turbine wires using copper split bolts or by soldering the connections. Wrap each connection with a generous amount of electrical tape.
- 4) Extend the wires straight from the turbine and tape them together every 3 feet. They will be much easier to push through the pipe as a group than one at a time.
- 5) If pipe insulation is to be used on the wires, a short piece (6 inches) should be taped securely onto the wires every 3 feet or so. This will keep the wires from contacting the pipe and will minimize the turbine noise that is transmitted to the tower.
- 6) Slip the guy wire hanger (coupler) onto the lower tower pipe near its top (guy wires toward the bottom).
- 7) Push the wires down through the lower pipe section. If it is too difficult to push the wires, then slide a guy wire up through the pipe and tape the wires to it. Pull the wires through the pipe using the guy wire.
- 8) Mount the turbine to the turbine mounting stub section as described in the turbine owner's manual.
- 9) Position the turbine mounting stub and lower tower sections together and slide the guy wire hanger / coupler over the joint. Tighten the two bolts to 18-20 ft.\*lb. of torque.

- 10) Run the turbine wires through the tower base and slide in the tower pipe. Tighten the set screw in the tower base to 8-10 ft.\*lb. of torque.

### **Step 7: Attaching Guy Wires to Anchors**

With the assembled tower laying on the ground the guy wires at the sides and rear of the tower should be attached now. Make sure that the bottom of the tower is positioned at the tower base so that the distances from the anchors to the guy wire attachment points on the tower will be the same as when the tower is vertical. Leave about 6 inches of slack in the wires to allow for any misalignment or unnoted elevation differences (the wires will be adjusted more precisely later). The side wires can be pulled to their anchors and attached using the wire rope thimbles provided with your tower kit.

Note: The thimbles may need to be spread open to install them on your anchors. This can be done with a pair of pliers. Be sure to press the open end of the thimbles back together (with pliers) before attaching the guy wires.

The rear wire length can be estimated by pulling it to a side anchor and placing a piece of tape on the wire at the distance of the side anchor. The rear wire will then be attached to its respective anchor at the point marked by the tape. This should make its length approximately correct when the tower is up (again, it will be readjusted, so don't worry about a few inches one way or the other). **Make sure that none of the guy wires are crossed and that the side wires are straight without the rear wire crossed on top of them!** Run the tail of the guy wire through the second clamp twice, forming a safety loop (as shown on page 15). Attach the side and rear wires securely as shown in the drawing with two clamps on each wire. Use 6-8 ft.-lb. of torque on each nut. It is important (for good strength) that the saddle part of each clamp is on the loaded (tower) side of the guy wire.

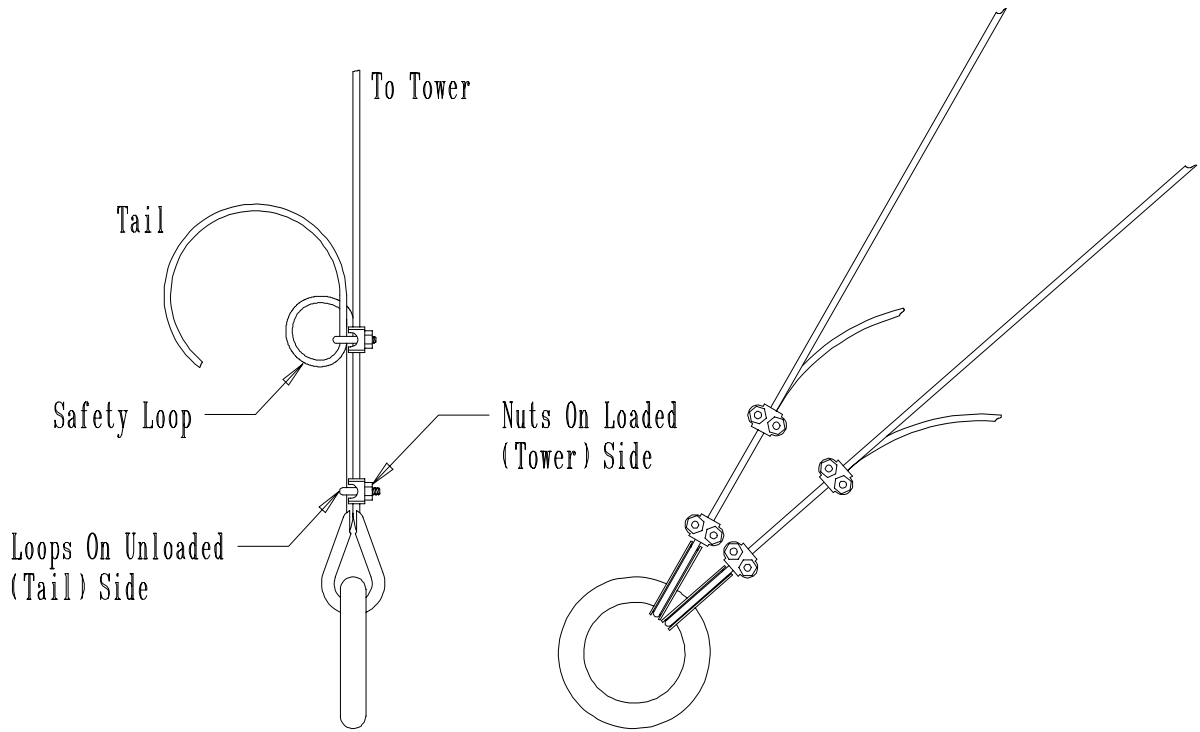

**MAKE SURE THAT ALL GUY WIRES ARE SECURE BEFORE PROCEEDING !**

At this point the turbine should be propped up on a box, chair, stool or milk crate so that the blades are not damaged when they are installed. Mount the blades onto the turbine at this time.

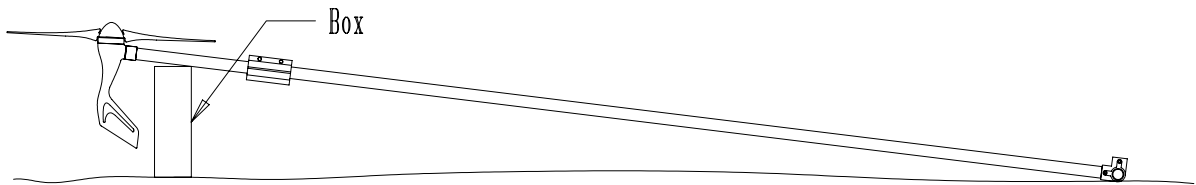

**MAKE SURE THAT ALL GUY WIRES ARE SECURE BEFORE PROCEEDING !**

**Step 8: Raising the Tower**

Before attempting to raise the tower be sure that all side and rear guy wire are attached and that all clamps are tight. Also be sure that the two bolts on the coupler are tight.

If two people are available one person should push the tower up into position while the other pulls by the unattached guy wire. With the tower off the ground a few feet make sure that all the wires are coming up cleanly. Be sure none of the wires are tangled and that the loops at the attachment points on the tower coupler are straight.

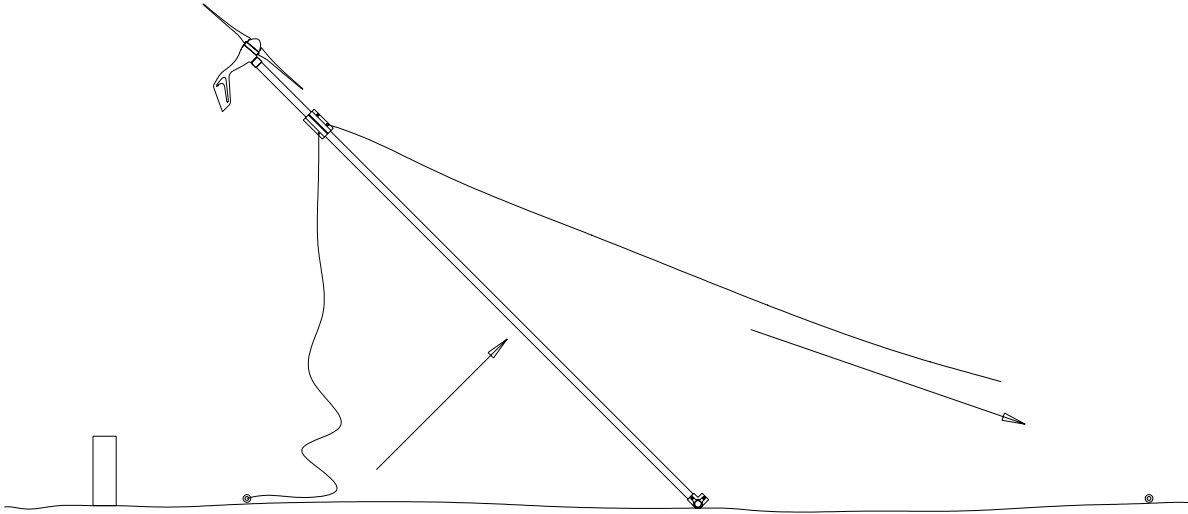

If the guy wires are too tight they may cause the tower to bow as it is raised. If this happens, lower the tower back to the ground and reduce the tension on the guy wires. Be sure to retighten the cable clamps before raising the tower. Once the tower is raised to vertical, attach the last guy wire to its anchor.

### **Step 9: Adjustment of Guy Wires**

First look to see if any of the guy wires are too tight and are causing the tower to bow.

If they are, then check to see which wire(s) are too tight (the wires act in pairs) and release the tension on one of the wires. To relieve tension on a wire, loosen the two cable clamps until the cable can be slid through them and let out some cable until there is no tension in the wire. It is easy to over tighten the guy wires, even by hand. The wires should only have the slack taken out with no real tension.

Now walk a short distance from the tower and look to see how straight it is. Focus on the angle of the tower and adjust the cables until the tower is straight up and down (a carpenter's level held against the tower can be helpful for this). To adjust the angle of the tower you will need to relax one wire and tighten the wire opposite to it. Repeat the process until the tower is straight.



Once the tower is straight, make sure that all the cable clamps are tight. If the tower is to be lowered, only undo the bolt side cable so that, when the tower is re-erected, only that cable will need to be readjusted.

**Step 10: Junction Box and Lightning Arrestor Installation**

A junction box for the wire connections can be attached to the tower base. A lightning arrestor can be installed on this box as well. We recommend an all weather box approved for outdoor use and of sufficient size for the wires to be connected. This should be available from your local electrical supply store. For the wire connections we recommend copper split bolts also available from your local electrical supply store. One hole of the junction box should hold a short threaded nipple attached to 1 ½ in. (nominal size) CPVC pipe adapter. This adapter will fit into the base of the tower and can be locked in place with a set screw. The other two holes should hold the lightning arrestor (if used) and a flexible conduit connector to route the wires into the ground. Generally, direct burial wires are used from the batteries to the tower base. These wires should be buried from the batteries (or shed / house) out to the tower base where they are routed into the junction box. The wires coming out of the junction box should all be trimmed to about 5 in. The turbine wires and the lightning arrestor should all be stripped and connected together with the split bolts. Once connected, they should be thoroughly wrapped with electrical tape and the lid to the junction box secured.

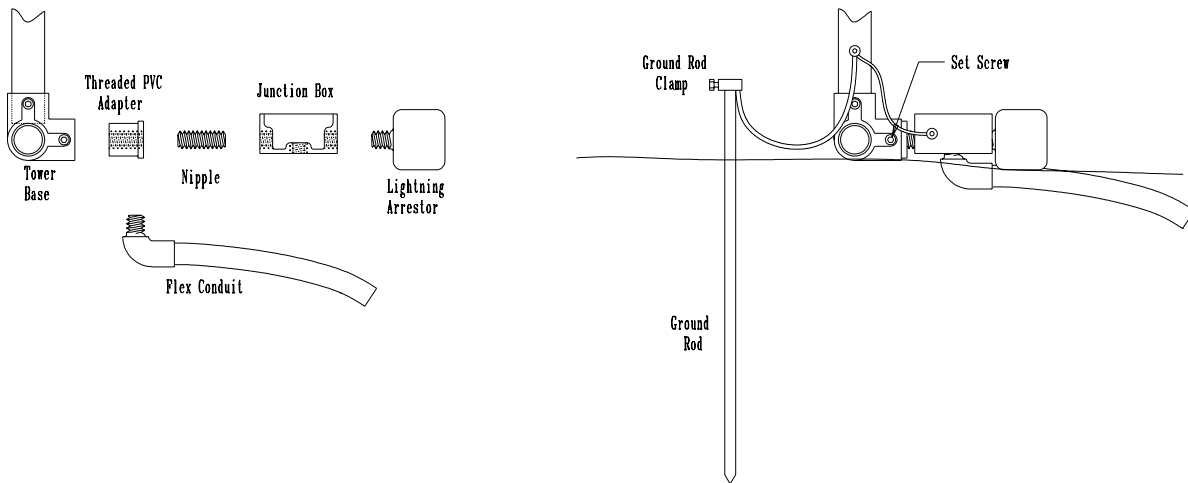

**Grounding**

To properly ground the tower to the earth a six to eight foot ground rod must be installed as close to the tower base as possible. A 10 gauge or larger wire should be firmly attached to the tower pipe near the bottom of the tower and clamped to the ground rod. The junction box should also be connected to this ground.

**Maintenance**

Periodically check to see that the guy wire tension is set properly and that the cable clamps have not loosened. There is no other maintenance required for this tower system.