

To de-energize or shut down the AC-coupled system:

1. Turn off (open) the AC circuit breakers. **1**
2. Turn off (open) the DC circuit breakers for the battery. **2**
Wait 5 minutes for the inverter to internally discharge itself.
3. Verify 0 Vdc on the first DC bus of the inverter by placing the voltmeter leads on **1b** and **1c**.
4. Verify 0 Vdc on the second DC bus by placing the voltmeter leads on **1b** and **1d**.
5. Verify 0 Vac on the AC output circuit breakers by placing the voltmeter leads on **2a** and **2c**. Repeat this step for **2b** and **2c**.
6. Verify 0 Vac on the grid-tied inverter terminals **3a** and **3b** (with neutral terminal **2c**).



WARNING: Burn Hazard
Internal parts can become hot during operation. Do not remove the cover during operation or touch any internal parts. Be sure to allow them sufficient time to cool down before attempting to perform any product maintenance.



WARNING: Lethal Voltage
Review the system configuration to identify all possible sources of energy. Ensure ALL sources of power are disconnected before performing any installation or maintenance on this equipment. Confirm that the terminals are de-energized using a validated voltmeter (rated for a minimum 1000 Vac and 1000 Vdc) to verify the de-energized condition.



WARNING: Lethal Voltage
The numbered steps will remove power from the inverters. However, sources of energy may still be present inside the GSLC and other locations. To ensure absolute safety, disconnect ALL power connections at the source.

Functional Test Points

Battery Voltage Test Points	1a 1b 1c 1d
AC OUT Voltage Test Points (Terminal bus bar = TBB)	2a 2b 2c
Grid-Tie Inverter Test Points	3a 3b 2c

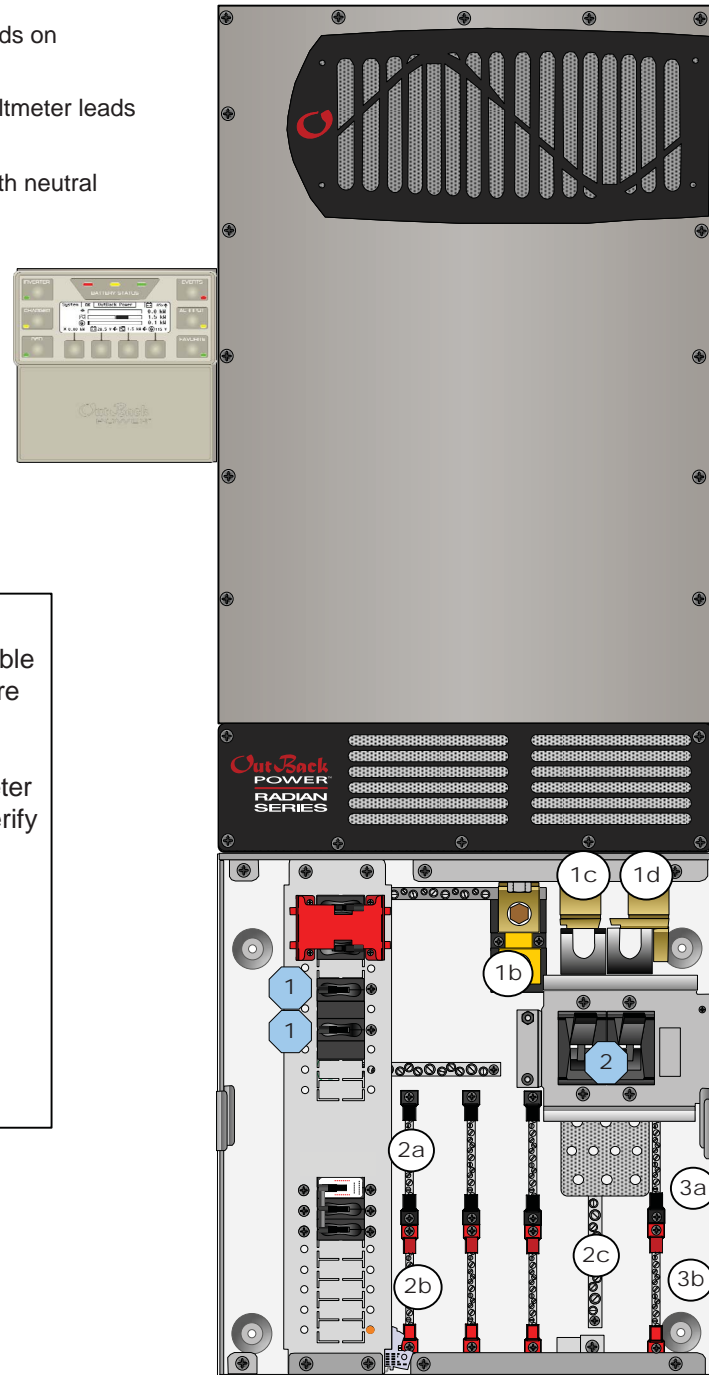

MATE3
System
Display and
Controller



PV and Grid-Tied
Inverter

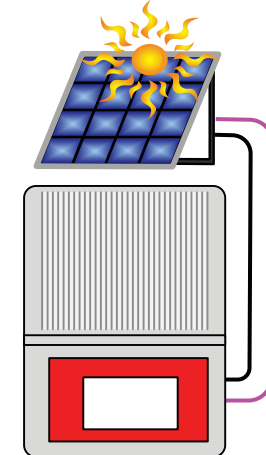

Battery Bank

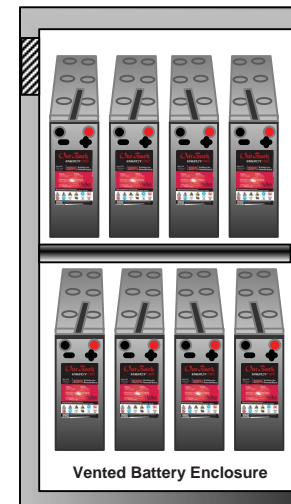

GS8048 Inverter/Charger

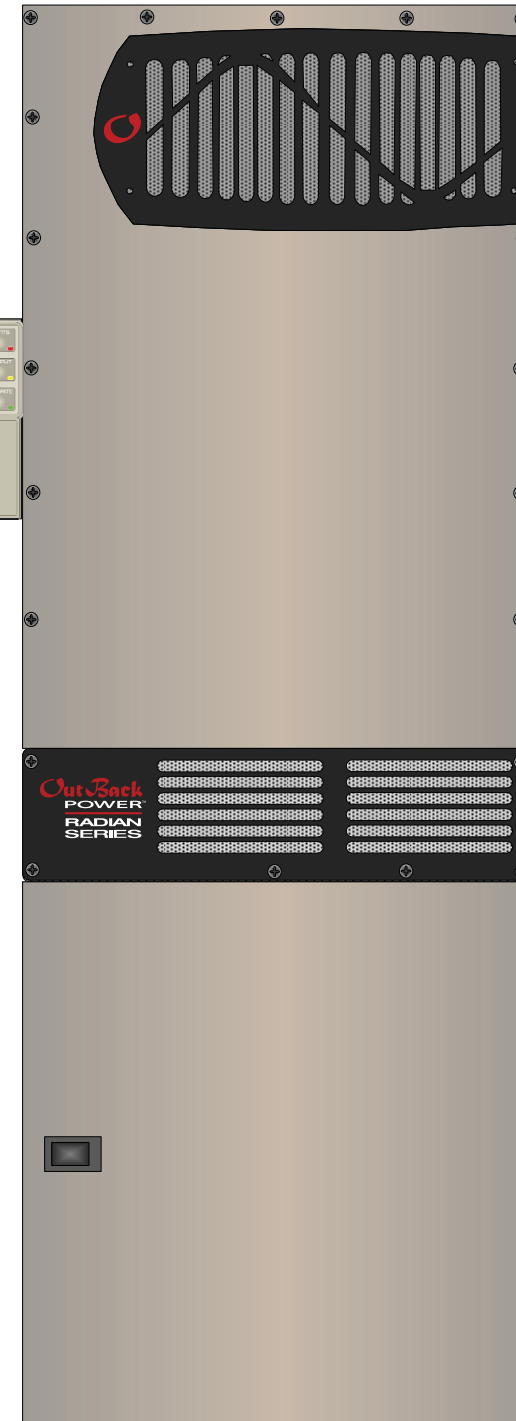

GS Load Center
(GSLC)

AC-Coupled Application

Major Components

Radian System Products

GS Load Center GSLC175-AC-120/240

Inverter/Charger GS8048

- Includes Remote Temperature Sensor (RTS)

System Display MATE3

- MATE3 uses FW-MB3 mounting bracket
- MATE3 requires revision 002.015.xxx or higher

Optional OutBack Components

FLEXnet DC Monitor (FN-DC)

Communications Manager HUB10.3
HUB10
HUB4

Customer-Supplied Components

Photovoltaic (PV) Array

Grid-Tied Inverter, 120/240 Vac

AC Sources Utility Grid (required)
AC Generator (optional)

Main Electrical Panel

Electrical Distribution Subpanel
(Protected Load Panel)

Battery Bank



Contact Technical Support:
Telephone: +1.360.618.4363
Email: Support@outbackpower.com
Website: www.outbackpower.com

IMPORTANT:
Not intended for use with
life support equipment.



⚡ WARNING: Fire/Explosion Hazard
Do not place combustible or flammable materials within 12 feet (3.7 m) of the equipment. This unit employs mechanical relays and is not ignition-protected. Fumes or spills from flammable materials could be ignited by sparks.

⚡ WARNING: Personal Injury
Use safe lifting techniques and standard safety equipment when working with this equipment.

📖 IMPORTANT:
Clearance and access requirements may vary by location. Maintaining a 36" (91.4 cm) clear space in front of the system for access is recommended. *Consult local electric code to confirm clearance and access requirements for the specific location.*

Radian Dimensions (includes MATE3):

29.1" (85 cm) tall X 23.9" (60.6 cm) wide

Radian Mounting:

- 1 Ensure the mounting surface is strong enough to handle 3 times the total weight of all the components. Add a piece of plywood if necessary to strengthen the surface.
- 2 Attach the wall bracket to the surface centering the mounting holes on the sides with the wall studs. Use all 6 mounting screws to secure the bracket.
- 3 Lift the inverter so that the inverter bracket is above the wall bracket.
- 4 Lower the inverter into place so that the inverter bracket slips into the wall bracket.
- 5 Secure the inverter to the surface using a minimum of 1 wall screw (or other appropriate hardware).
- 6 Follow the instructions for installing the GS Load Center.
- 7 Follow the instructions for installing the bracket for the MATE3.
- 8 Follow appropriate instructions for installing the PV array and grid-tied inverter (if not already present).

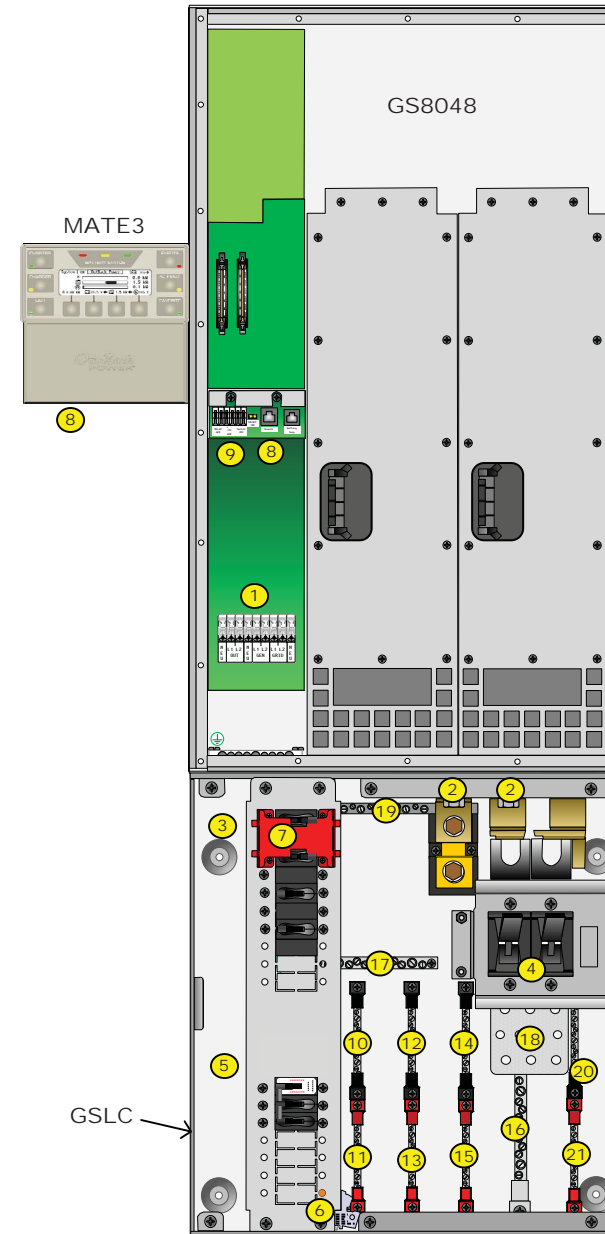
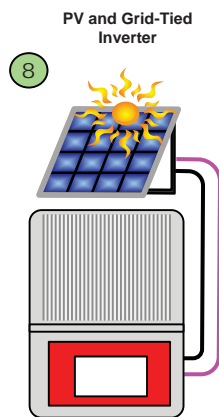
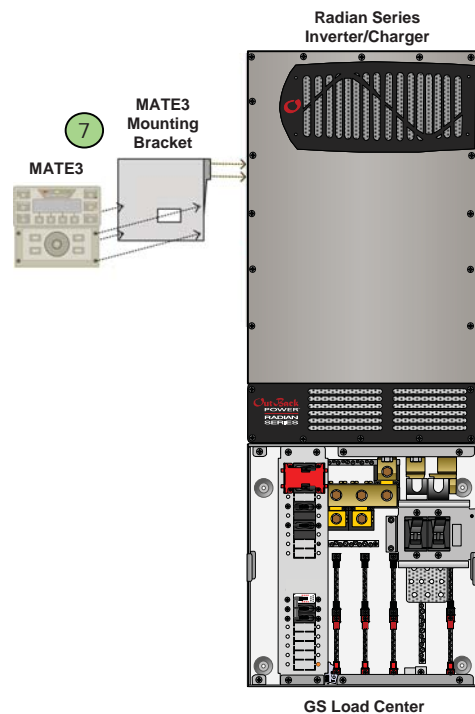
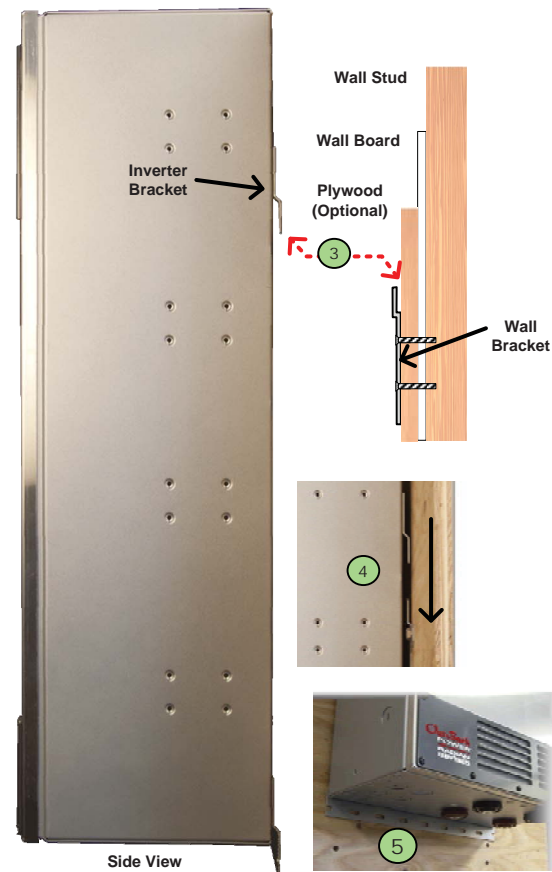
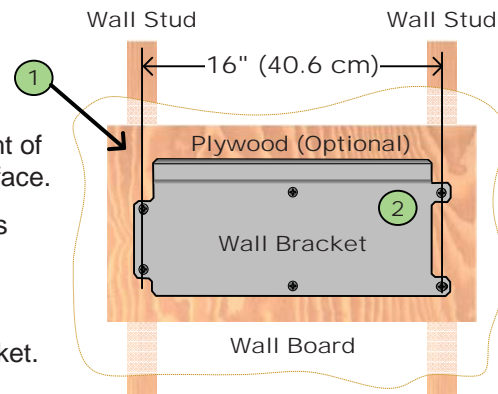

- 1 AC Terminals - Inverter
- 2 DC Terminals - Inverter
- 3 AC Circuit Breakers
- 4 DC Circuit Breakers
- 5 Remote Operated Circuit Breaker (ROCB)
- 6 Relays
- 7 Mechanical Interlock (Bypass)
- 8 Communication Ports
- 9 Auxiliary Terminals
- 10 AC OUT Bus Bar L1
- 11 AC OUT Bus Bar L2
- 12 GRID IN Bus Bar L1
- 13 GRID IN Bus Bar L2
- 14 GEN IN Bus Bar L1
- 15 GEN IN Bus Bar L2
- 16 AC Neutral
- 17 Ground
- 18 DC Positive (+) Plate
- 19 DC Negative (-) Bus Bar
- 20 Grid-Tied Inverter Bus Bar L1
- 21 Grid-Tied Inverter Bus Bar L2

AC Wire Sizes and Torque Values

Wire Size		Torque	
AWG	mm ²	In-lb	Nm
#14 - 10	2.5 - 6	20	2.3
#8	10	25	2.8
#6 - 4	16 - 25	35	4.0
#3	35	35	4.0
#2	35	40	4.5
#1	50	50	5.6
1/0	70	50	5.6

It is recommended that conductors be #6 AWG THHN copper, or larger, rated to 75°C (minimum) unless local code requires otherwise.

Minimum DC Cable based on the DC Circuit Breaker

DC Circuit Breaker	Cable Size	Torque	
		In-lb	Nm
60	#6 AWG (16 mm ²)	35	4.0
80	#4 AWG (25 mm ²)	35	4.0
125	1/0 (70 mm ²)	50	5.6
175	2/0 (70 mm ²)	225	25.4
250	4/0 (120 mm ²)	225	25.4

Torque Requirements

Circuit Breaker Stud	Torque	
	In-lb	Nm
M8	20	2.3
1/4 - 20	35	4.0
5/16 - 18	50	5.6
3/8 - 16	225	25.4
DC Plates		
Upper holes (+)	60	6.8
Lower holes (+)	50	5.6
Shunt Bolts (-)	60	6.8

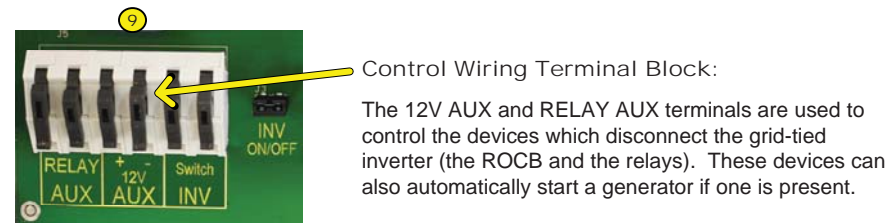

⚠ CAUTION: Equipment Damage
When connecting cables from the inverter to the battery terminals, ensure the proper polarity is observed. Connecting the cables incorrectly can damage or destroy the equipment and void the product warranty.

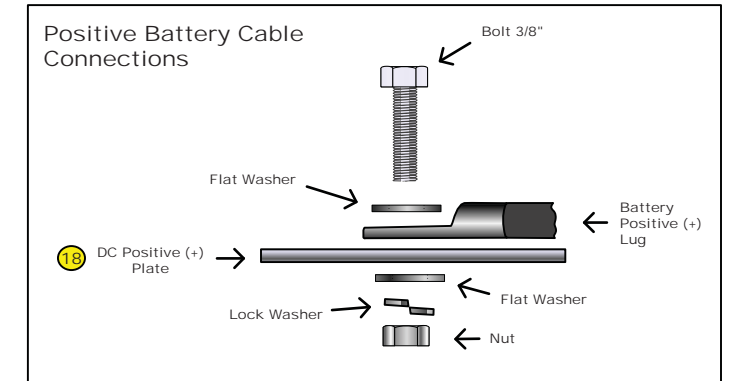
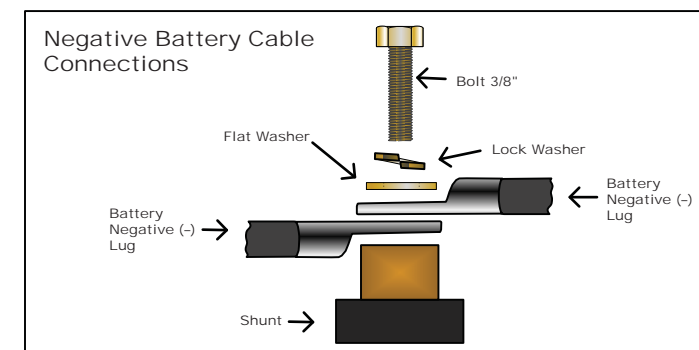

Pre-startup Procedures:

1. Double-check all wiring connections.
2. Inspect the enclosure to ensure no tools or debris has been left inside.
3. Disconnect all AC loads at the backup (or critical) load panel.
4. Disconnect the AC input feed to the GSLC at the source.

CAUTION: Equipment Damage
Incorrect polarity will damage the equipment.

To energize the AC-coupled system:

1. Using a digital voltmeter (DVM), verify 48 Vdc on the DC input terminals by placing the DVM leads on (1a) and (1b).
Confirm that the battery voltage is correct for the inverter model.
Confirm the polarity.
2. Turn on (close) the DC circuit breakers from the battery bank to the inverter. **1**
3. Perform all programming (see the next section).
4. If the inverter is in the off state, turn it on. **2**
5. Verify 120 Vac on the AC Output L1 TBB by placing the DVM leads on (2a) and (2c).
6. Verify 120 Vac on the AC Output L2 TBB (2b) and (2c).
7. Verify 240 Vac between the AC Output TBBs by placing the DVM leads on (2a) and (2b).
8. Turn on (close) the AC output circuit breakers. **3**
9. No voltage should be present on the grid-tied inverter terminals (3a) and (3b).
Verify the condition of these terminals using the DVM (with neutral terminal (2c)).
10. Start the generator (if present). Verify 120/240 Vac at the location of the AC sources.
11. Turn on the AC input feed to the GSLC at the source.
12. Verify 120 Vac on the GRID IN L1 TBB by placing the DVM leads on (4a) and (2c).
13. Verify 120 Vac on the GRID IN L2 TBB (4b) and (2c).
14. Verify 240 Vac between the GRID IN TBBs by placing the DVM leads on (4a) and (4b).
15. Verify 120 Vac on the GEN IN L1 TBB by placing the DVM leads on (5a) and (2c).
16. Verify 120 Vac on the GEN IN L2 TBB (5b) and (2c).
17. Verify 240 Vac between the GEN IN TBBs by placing the DVM leads on (5a) and (5b).
18. Turn on the AC disconnects at the backup (or critical) load panel and test the loads.
19. Turn on (close) the grid AC input circuit breaker. **4**
20. Turn on (close) the ROCB (6). AC should be present on the grid-tied inverter terminals (3a) and (3b). Verify 120/240 Vac on these terminals using the DVM (with neutral terminal (2c)).
21. Check the grid-tied inverter for proper functionality.
- Optional steps to test generator and ROCB function:
 22. Turn on either the 12V AUX or the RELAY AUX menu item, or the generator circuit breaker (if present). Turning on any of these three items will energize the front relay (7).
The LED indicator on the front relay will illuminate. At the same time the ROCB (6) will automatically turn off (open). No AC should be present on the grid-tied inverter terminals (3a) and (3b). Verify the condition of these terminals with the DVM (with neutral terminal (2c)).
 23. Turn off the generator or AUX. The front relay will de-energize. The LED indicator will turn off. The ROCB will automatically turn on (close). AC should be present on the grid-tied terminals. Repeat these steps for the other two items from Step 22 if testing is necessary.

Relays (Top View)

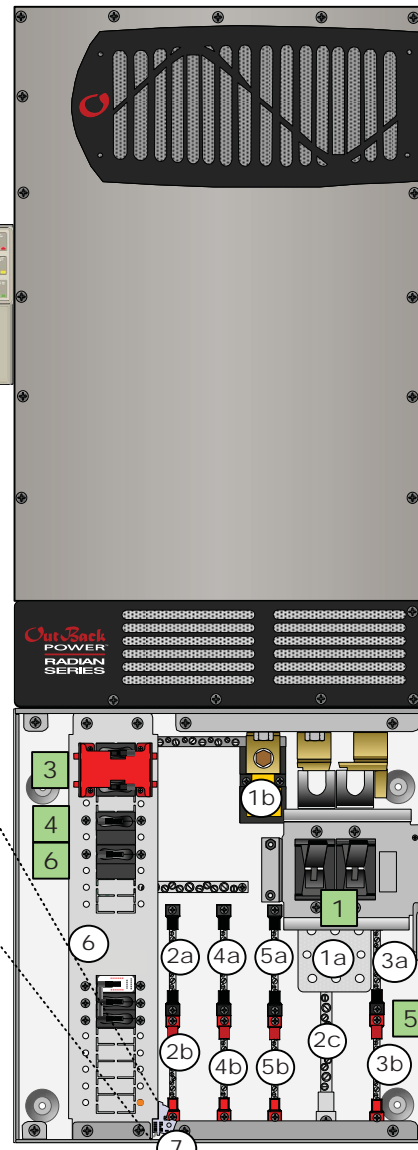
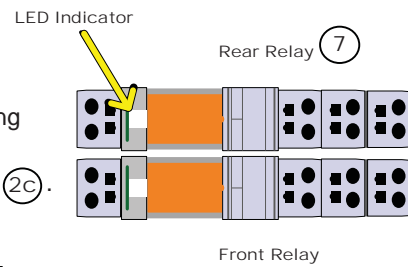

Functional Test Points

Battery Voltage Test Points (1a) (1b)	
AC OUT Voltage Test Points (Terminal bus bar = TBB) (2a) (2b) (2c)	
Grid-Tie Inverter Test Points (3a) (3b) (2c)	
GRID IN Voltage Test Points (Terminal bus bar = TBB) (4a) (4b) (2c)	
GEN IN Voltage Test Points (Terminal bus bar = TBB) (5a) (5b) (2c)	
ROCB (6)	Front Relay (7)

IMPORTANT:

Steps 1 through 5 required for proper operation.

Programming should be done by a qualified installer who is trained on programming inverter power systems. Failure to program accurate parameters for the system could potentially cause equipment damage. Damage caused by inaccurate programming is not covered by the limited warranty for the system.

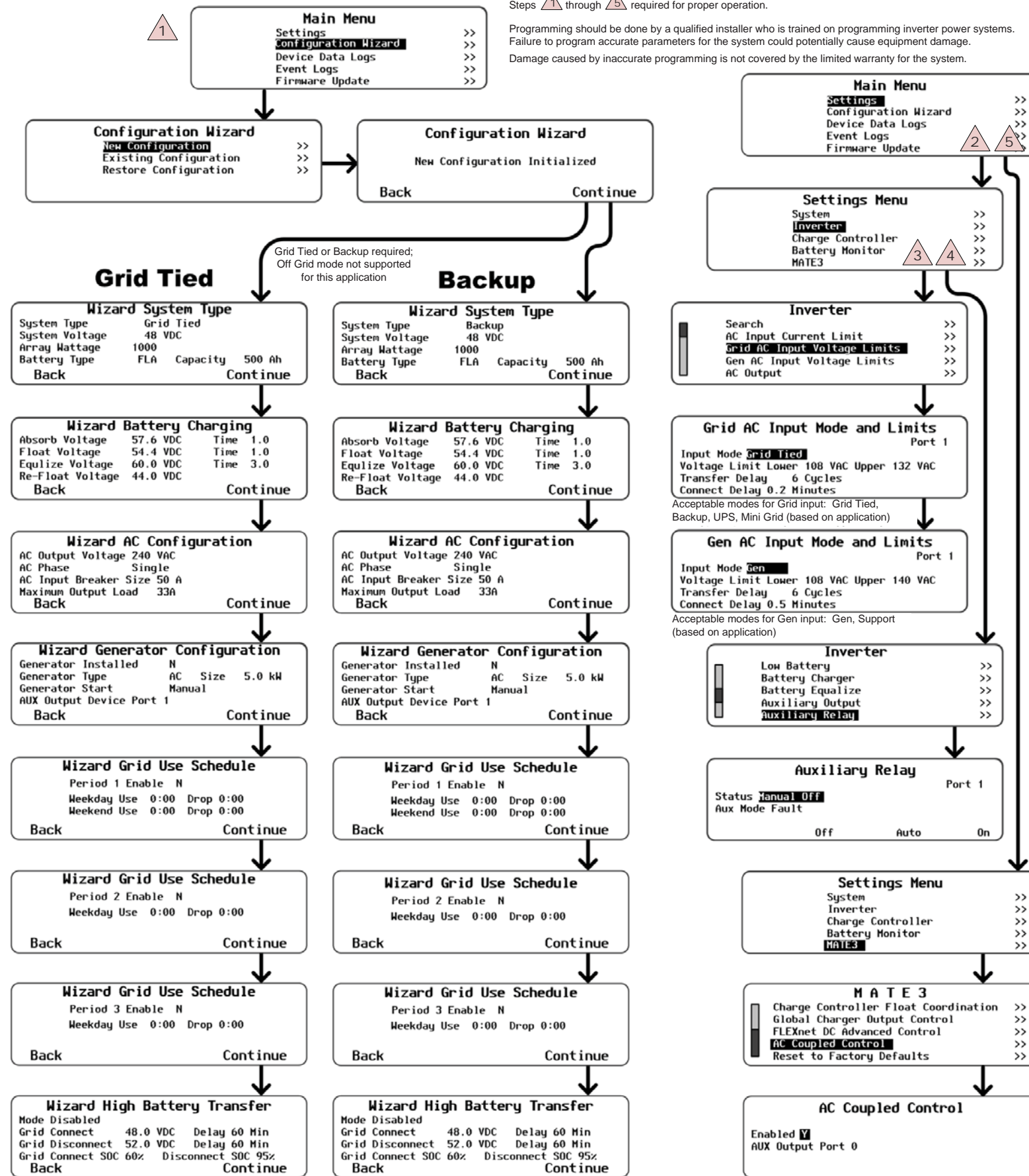

NOTE: See the MATE3 manual for Advanced Generator Start and other setup features

