

Battery Monitor Kit (ME-BMK)



Kit includes

- Sense module
- DC shunt
50mv/500 amp shunt
(not included in the ME-BNK-NS kit)
- Twisted pair wire
5' length, 18 AWG wire
- Communication cable
10' length, 4-conductor,
telephone standard

MODEL NUMBERS

- ME-BMK
- ME-BMK-NS (no shunt)

AVAILABLE FOR

- Renewable
Energy Systems
Off-grid Power
Back-up Power
- Marine Systems
- RV Systems

WORKS WITH

- ME Series
- MM-AE Series
- MS Series
- MS-PAE Series
- RD Series

Monitoring your battery bank is easy with the Battery Monitor Kit (ME-BMK)* from Magnum Energy. Acting as a “fuel gauge” for your batteries, the ME-BMK monitors their state of charge (SOC) and then provides this information in an easy-to-understand display via the ME-ARC or ME-RC remotes. With accurate SOC readings, you can avoid unnecessary battery recharging, saving on fuel and long-term maintenance costs.

If you already have a Magnum Inverter/Charger and Magnum Remote*, the ME-BMK is an easy retrofit. Simply install the kit according to the installation manual and begin monitoring your battery bank via the “Meter” button on your ME-RC.

Available readings from the ME-BMK / ME-BMK-NS

- State of Charge (SOC)
0 - 100%
- DC volts
- DC amps
- Amp hours in/out
- Resettable amp hours out
- Total amp hours out
- Minimum volts DC
- Maximum volts DC
- Temperature compensated
- Auto detects input voltage

ME-BMK Basic Configuration Diagram

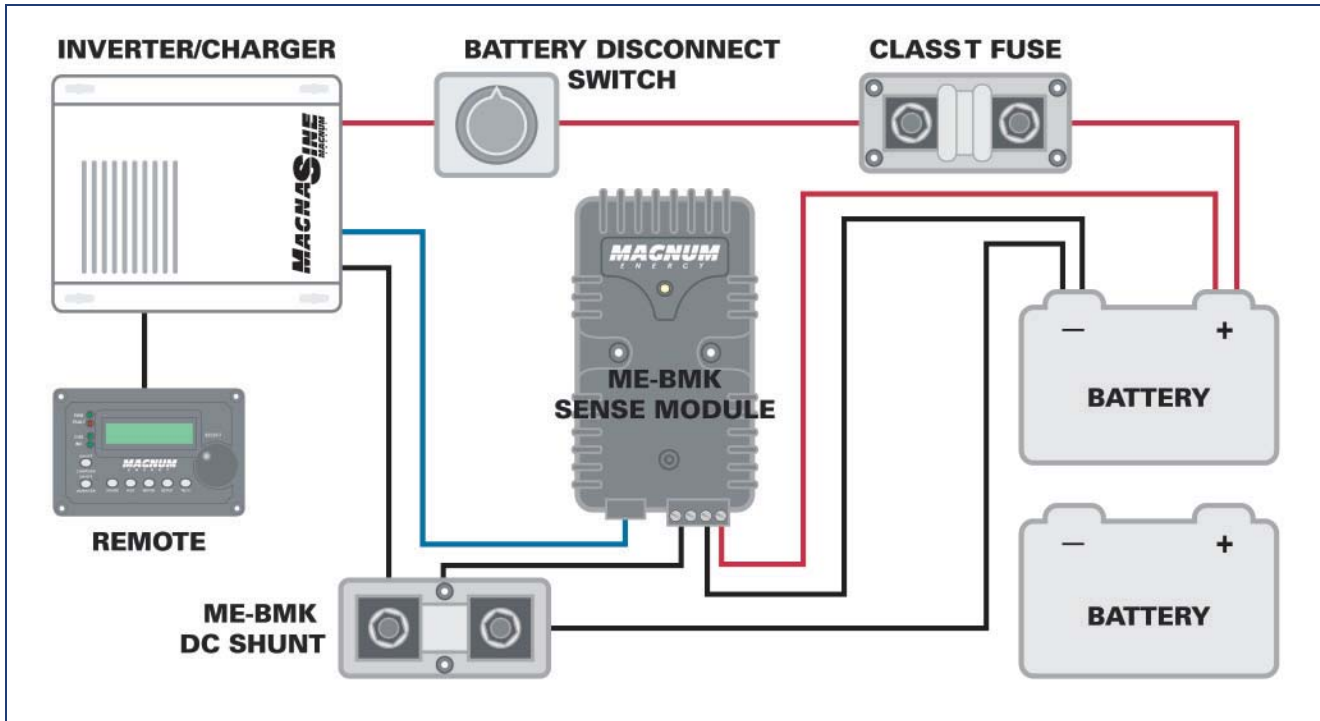

ME-BMK Specifications

ME-BMK

DC volts	7 to 70 ($\pm 0.5\%$) auto voltage detection
DC amps	± 0.1 to 999 ($\pm 1.0\%$)
Battery SOC %	0 to 100% (1% increments)
Power draw	< .6 watts
Amp hours in/out	$\pm 32,768$ amp hours (1 AH increments)
rAH out (resettable amp hours removed)	0 to 65,535 amp hours, resettable (0.1 AH increments)
tAH out (total amp hours removed)	0 to 65,535,000 amp hours (0.1 k or 100 AH increments)
Minimum/maximim DC	7 to 70 VDC, resettable
Shipping weight	2 lb (.9 kg)
Kit includes	Manual, sense module, DC shunt, twisted pair wire, and communication cable
Sense wire	Twisted pair –blue & orange, 5' length, 18 AWG wire
Communication cable	4-conductor, 10' twisted pair, telephone standard
Remote requirements	Use with an ME-RC with firmware revision of 2.0 or higher or an ME-ARC (all revisions)

DC Shunt (not included with the ME-BMK-NS kit)

Resistance	0.1 milliohm (500A at 50mV)
Continuous current	410 amperes maximum
Overload current	Overloads to 500 amps for less than 5 minutes if normally operated at less than 300 amps

Magnum Energy, Inc.

1111 80th Street SW, Suite 250
Everett, Washington 98203 USA

The Powerful Difference

Phone: 425-353-8833
Fax: 425-353-8390
Web: www.magnumenergy.com

Testing for specifications at 25° C
Specifications subject to change without notice.

August 2012, Rev C

Part #64-0480

Blue Pacific Solar



www.BluePacificSolar.com

