

RESU[®]

Installation Manual for RESU10H

The information included in this manual is accurate at the time of publication. However, this manual is subject to change without prior notice. In addition, the illustrations in this manual are meant only to help explain system configuration concepts and installation instructions.

Please note the image shown is for illustration purposes only.



CAUTION

After installation, the installer must explain the User Guide to the end-user.

Contents

1	Safety	5
1.1	Symbols.....	5
1.2	Safety instructions	6
1.2.1	General safety precautions	6
1.2.2	Battery handling guide	6
1.2.3	Response to emergency situations	8
1.3	Warning label	9
1.4	Qualified personnel	10
2	Product Introduction	11
2.1	Technical data	11
2.1.1	Dimensions and weight	11
2.1.2	Performance.....	12
2.2	Feature	13
2.3	Packaging specification	13
3	Installation	14
3.1	Mechanical requirements	14
3.1.1	Unboxing the package.....	15
3.1.2	Items in the package.....	16
3.1.3	Installation locations	16
3.1.4	Clearance.....	17
3.1.5	Tools & safety gears required	17
3.1.6	Mounting bracket.....	19
3.1.7	Appearance and dimension	20
3.1.8	System clearance	20
3.1.9	Installing the battery pack.....	21
3.2	Cable connection	24
3.2.1	Auxiliary power switch and spring terminal blocks	26

4	Commissioning	27
4.1	LED indicators	27
4.2	Powering up the battery pack	28
4.3	Shutting off the battery pack	28
5	Troubleshooting	29
5.1	Troubleshooting	29
6	Uninstallation & Return	30
6.1	Return/replacement instructions	30
6.1.1	Uninstallation from the wall	30
6.1.2	Contact information	32

1 Safety

1.1 Symbols



Caution, risk of electric shock



Do not place nor install near flammable or explosive materials.



Install the product out of reach of children.



Read the instruction manual before starting installation and operation.



Heavy weight may cause serious injury to the back.



Do not dispose of the product with household wastes.

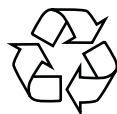

Recyclable



Disconnect the equipment before carrying out maintenance or repair.



Observe precautions for handling electrostatic discharge sensitive devices.

1.2 Safety instructions

For safety reasons, installers are responsible for familiarizing themselves with the contents of this document and all warnings before performing installation.

1.2.1 General safety precautions

Over-voltages or wrong wiring can damage the battery pack and cause deflagration, which can be extremely dangerous.

All types of breakdown of the product may lead to a leakage of electrolyte or flammable gas.

Avoid installing the battery pack where flammable materials are stored. Do not install in places where explosive gas or chemicals are present.

The utility grid, solar input, and battery voltage must be disconnected from the Battery Pack wiring. Wiring must be carried out by a qualified personnel.

Battery Pack is not user serviceable. High voltage is present in the device.

The electronics inside the Battery Pack are vulnerable to electrostatic discharge.

Be sure to be grounded before handling the battery pack.

Read the label with Warning Symbols and Precautions, which is visibly under to the Battery Cover (see Section 1.3)

1.2.2 Battery handling guide

- Do not expose battery to open flame.
- Do not place the product nearby flammables. It may lead to fire or explosion in case of accident.
- Do not expose or place near water sources like downspouts or sprinklers.
- Do not store this product in a place exposed to direct sunlight.
- A ventilated area is strongly recommended for handling the product.
- Store at cool and dry place. (Do not store in greenhouses and storage areas for hay, straw, chaff, animal feed, fertilizers, vegetables or fruit products.)
- Store the product on a flat surface.
- Store the product out of reach of children and animals.
- Store the product where it should be minimal dust and dirt in the area.

- Do not disconnect, disassemble or repair by unqualified personnel. Services must be made by qualified personnel only.
- Do not damage the unit in such ways as dropping, deforming, impacting, cutting or penetrating with a sharp object. It may cause a leakage of electrolyte or fire.
- Do not touch if liquid is spilled on the product. There is a risk of electric shock. Handle the battery wearing the insulated gloves.
- Do not step on the product or the product package. The product may be damaged.
- Do not place any foreign objects on the top of the Battery Pack and on the cooling fin.
- Do not put the battery pack upside down on the ground.
- Do not connect anode and cathode terminal block opposite direction.
- Do not charge or discharge damaged battery.
- If the battery pack is installed in the garage then ensure the product is above the height of the vehicle bumper.
- The RESU battery pack has been certified IP55 and can be installed indoors as well as outdoors. However, if installed outdoors, do not allow the battery pack to be exposed to direct sunlight and water source as it may cause :
 - Power limitation phenomena in the battery (with a resulting decreased energy production by the system)
 - Premature wear of the electrical/electromechanical components and mechanical components.
 - Reduction in performance, service life and possible damage of the battery
- Only use the product with a LGC-authorized inverter. For a list of compatible inverters, go to :
<http://www.lgesspartner.com>
- Do not connect any AC conductors or Photo-voltaic conductors directly to the battery pack and should be only connected to the Inverter

1.2.3 Response to emergency situations

The RESU10H battery pack comprises multiple batteries that are designed to prevent hazards resulting from failures. However, LG Chem cannot guarantee their absolute safety.

- If a user happens to be exposed to internal materials of the battery cell due to damage on the outer casing, the following actions are recommended.

Inhalation : Leave the contaminated area immediately and seek medical attention.

Eye contact : Rinse eyes with running water for 15 minutes and seek medical attention.

Contact with skin : Wash the contacted area with soap thoroughly and seek medical attention.

Ingestion: Induce vomiting and seek medical attention.

If a fire breaks out in the place where the battery pack is installed, perform the following countermeasures:

- **Fire extinguishing media**

Respirator is not required during normal operations.

Use FM-200 or CO₂ extinguisher for battery fire.

Use an ABC fire extinguisher, if the fire is not from battery and not spread to it yet.

- **Fire fighting instructions**

1. If fire occurs when charging batteries, if it is safe to do so, disconnect the battery pack circuit breaker to shut off the power to charge.
2. If the battery pack is not on fire yet, extinguish the fire before the battery pack catches fire.
3. If the battery pack is on fire, do not try to extinguish but evacuate people immediately.



WARNING

There may be a possible explosion when batteries are heated above 150°C.
When the battery pack is burning, it leaks poisonous gases. Do not approach.

- **Effective ways to deal with accidents**

On land : Place damaged battery into a segregated place and call local fire department or service engineer.

In water : Stay out of the water and don't touch anything if any part of the battery, inverter, or wiring is submerged.

Do not use submerged battery again and contact the service engineer.

1.3 Warning label

Warning labels and other relevant labels are attached to the inside of the battery pack.

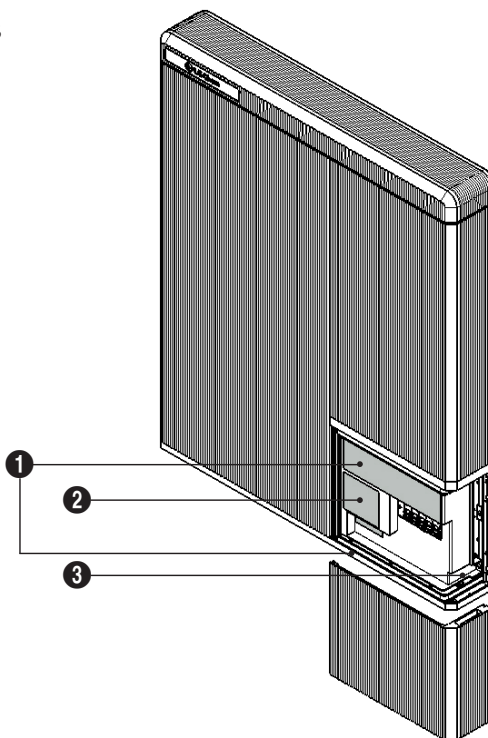

1. Warning label

<p>⚠️ ⚡ DANGER / HIGH VOLTAGE INSIDE</p> <p>Do not disassemble or repair the inverter system, electric shock or burns. Service by authorized personnel only. Do not charge or discharge an battery, if they are to fault, electric shock or burns. Do not attempt to break open the unit. The units are only serviceable by certified personnel. In such case, please contact LG Chem ESS QA Division (Direct Contact Number / E-Mail: +82-43-219-2892 / qa@lgchem.com). Do not touch near open flame or incinerator. Keep out of reach of children or animals. Do not install the product in the place exposed to the direct sunlight.</p> <p>Verboten zu zerlegen oder zu reparieren, um Verletzungen oder Stromschlag oder Brände zu vermeiden. Nur geschulte Fachkräfte dürfen arbeiten. Verbotene Aufladung oder Entladung. Die Einheit ist nur durch zertifiziertes Personal bedienbar. In solchem Fall kontaktieren Sie bitte LG Chem-ESS-DA Abteilung (Direkter Kontakt/Nummer / E-Mail: +82-43-219-2892 / qa@lgchem.com). Praktische Sie die Batterie nicht in einer offenern Feuer oder Zerstreuung. Halten Sie Kinder und Tiere fern. Installieren Sie die Batterie nicht in Umgebungen wo sie direkter Sonneneinstrahlung ausgesetzt ist.</p> <p>Ne pas démontez ou réparer par soi-même des batteries, chocs électriques ou brûlures. Seul un personnel de maintenance qualifié est autorisé à intervenir sur l'appareil. Ne pas charger et décharger les batteries. Cela risque d'engendrer des défauts, chocs électriques ou brûlures. Ne pas tenter d'ouvrir l'appareil. Les unités ne sont que serviceable par un personnel certifié. Dans ce cas, veuillez contacter LG Chem ESS QA Division (numéro direct de contact / E-mail: +82-43-219-2892 / qa@lgchem.com). Ne pas toucher près d'une flamme ou incendie produit. Tenir hors de portée des enfants et d'animaux.</p> <p>Ne pas installer le produit dans un endroit directement exposé au soleil. Préférer, même si le produit continue d'être capable, l'opérer à partir d'un endroit dans les lignes de l'ordinateur. Assurez-vous donc que l'ordinateur est également hors tension durant les interventions de maintenance. Évitez l'appareil sans protection enterrée en risque de foudre. Méfiez de débrancher une batterie pour porter ou déplacer l'appareil. Si un défaut de la terre est intégré alors il y a risque de choc électrique. Dans ce cas ne peut que la mise à la terre ne fonctionne pas.</p>		
<p>⚠️ WARNING If the FAULT LED shows, refer to the User Guide to : ① open the wiring box; ② turn off the toggle switch and the circuit breaker; then ③ contact LG Chem or your service provider. Otherwise, the battery may not operate properly.</p>		

2. Product label

<p>LG Chem</p> <p>ANSI/MIL-19131 ANSI/MIL-19133</p> <p>ICP16102354E1P42S2E1-10+4S05</p>	
<p>Battery type Batterietyp Type de batterie</p> <p>Li-Ion</p>	<p>Rated voltage Nennspannung Tension de la batterie</p> <p>350-400V</p>
<p>Product name Produktname Nom du produit</p> <p>RES17SH</p>	<p>Rated capacity Nennkapazität Capacité nominale</p> <p>63Ah</p>
<p>Model name Modellname Nom du modèle</p> <p>R1563P3SSEG1</p>	<p>Nominal energy Nennenergie Énergie nominale</p> <p>3.9kWh</p>
<p>Total weight Gesamtgewicht Poids total</p> <p>17kg(37lbs)</p>	<p>Max. Allow Voltage Maximale Spannung Tension maximale autorisée</p> <p>500V</p>
<p>Exclusion type Auslasskategorie Type de batterie</p> <p>PF22</p>	<p>Normal voltage (Charge/Discharge) Nennspannung (Ladung/Entladung) Tension normale (Charge/Entcharge)</p> <p>440V / 400V</p>
<p>Safety features Sicherheitsmerkmale Caractéristiques de sécurité</p> <p>Isolated Isoliert Isolé</p>	<p>Max. Charge Temp. Current Max. Spitzstrom bei höchster Temperatur Chargeur maximum de courant de chaleur</p> <p>15.8A</p>

3. Traceability label

1.4 Qualified personnel

This guide and the tasks and procedures described herein are intended for use by skilled workers only. A skilled worker is defined as a trained and qualified electrician or installer who has all of the following skills and experience:

- Knowledge of the functional principles and operation of on-grid and off-grid (backup) systems.
- Knowledge of the dangers and risks associated with installing and using electrical devices and acceptable mitigation methods.
- Knowledge of the installation of electrical devices
- Knowledge of and adherence to this guide and all safety precautions and best practices.

2 Product Introduction

2.1 Technical data

2.1.1 Dimensions and weight

RESU10H	
P/N	EVEPB00100B0
Width	744 mm (29.3")
Height	907 mm (35.7")
Depth	206 mm (8.1")
Weight ¹⁾	97 kg (214 lbs)

1) A battery pack's weight varies slightly.

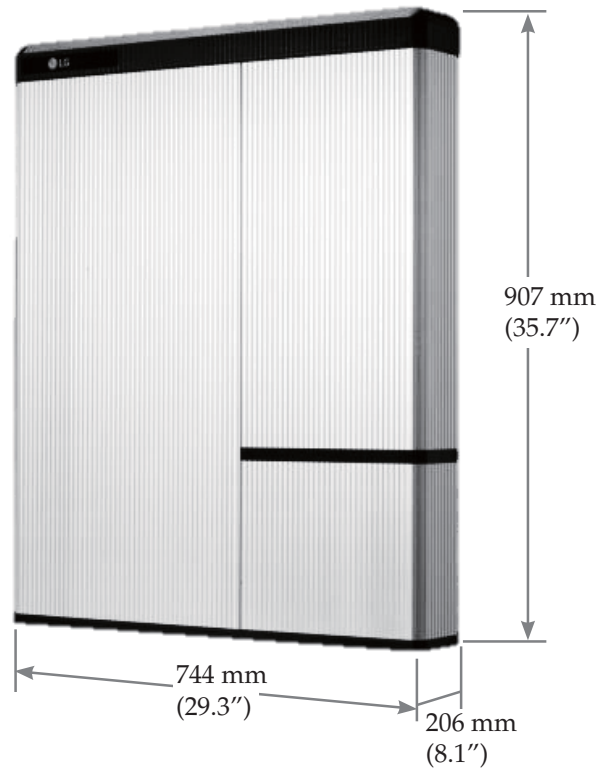

2.1.2 Performance

RESU10H

Electrical Characteristics		
Total Energy Capacity ¹⁾		9.8 kWh@25°C (77°F), 100% State of Energy
Usable Energy Capacity ¹⁾		9.3kWh
Battery Capacity		63 Ah
Voltage Range	Charge	400 to 450 VDC
	Discharge	350 to 430 VDC
Absolute Max. Voltage		520VDC
Max. Charge/Discharge Current		11.9A@420V / 14.3A@350V
Max. Charge/Discharge Power ²⁾		5kW
Peak Power ³⁾ (only discharging)		7kW for 10 sec.
Peak Current (only discharging)		18.9A@370V for 10 sec.
Communication Interface		RS485
DC Disconnect		Circuit Breaker
Connection Method		Spring Type Connector
User interface		LEDs for Normal and Fault operation
Operating Conditions		
Installation Location		Indoor / Outdoor (Wall-Mounted)
Operating Temperature		14 to 113°F (-10 to 45°C)
Operating Temperature (Recommended)		59 to 86°F (15 to 30°C)
Storage Temperature		-22 to 131°F (-30 to 55°C)
Humidity		5% to 95%
Altitude		Max. 6,562ft (2,000m)
Cooling Strategy		Natural Convection
Certification		
Safety	Cell	UL1642
	Battery Pack	UL1973 / CE / RCM / TUV(IEC 62619)
Emissions		FCC
Hazardous Materials Classification		Class 9
Transportation		UN38.3
Ingress Rating		IP55

※ Test Conditions - Temperature 25°C, at the beginning of life.

1) Battery Cell Only energy capacity at Depth of Discharge 95%.

2) LG Chem recommends 3.3kW for maximizing battery lifetime.

3) Peak Current excludes repeated short duration(less than 5 sec. of current pattern).

2.2 Feature

- Compact Energy storage unit for domestic photovoltaic system compatibility
- Residential 400V DC battery pack system : Daily cycle residential battery system
- No Additional Devices : Aux Power and Protection Devices* Included
 - *Protection Devices
 - Inverter interface (between Battery Pack and Inverter) : Over Voltage, Over Current, External Short Circuit, Reverse Polarity, Inrush Current, Ground Fault , Over Temp.
 - Battery inside (between Li-Ion battery and DC/DC converter) : Internal Short Circuit, Over Voltage, Over Current, Over Temp, Under Voltage
- Flexible installation : Indoor or Outdoor

2.3 Packaging specification

Category	Contents			
Size (LxWxH) (mm)	960 (37.8")	1,070 (42.2")	450 (17.7")	Outer Size
Qty/Box (ea)	1			1 piece X 2 layers
Packaging Materials	Box	Corrugated Cardboard		Disposable
	Inner	EPS		Disposable
	Pallet	Wood		Disposable
Weight (kg)	Product	102 (225lbs)		1 piece/Box (Battery + Package Items)
	Packaging	31 (68lbs)		Pallet + Box + Inner
	Gross	133 (293lbs)		Product + Packaging

3 Installation

3.1 Mechanical requirements

3.1.1 Unboxing the package

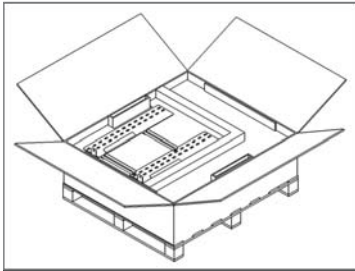

1. Cut the packing tape and open the carton.

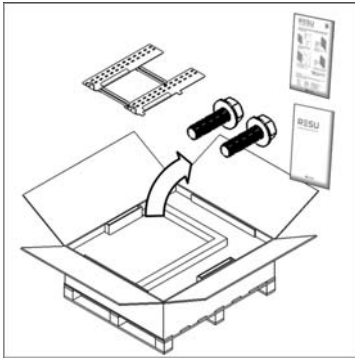

2. Pull out other items.
Take them out and check if any item is missing.
See Package items on section 3.1.2

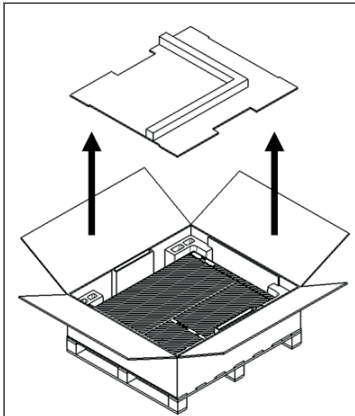

3. Remove the wall bracket guide pad & cushioning pad.

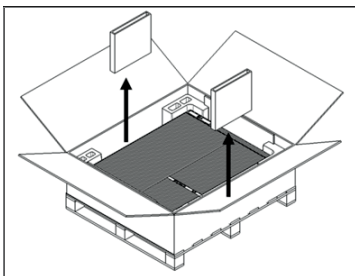

4. Remove the side pad.

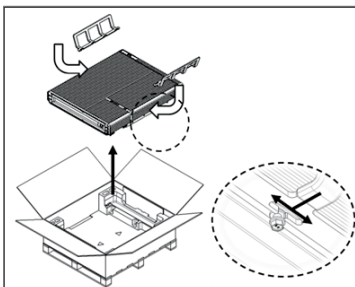

5. Pull out the battery pack using handles and stand it up.
(Lift handles are sold optionally for this product.)

 **CAUTION**

According to regional regulations, several people may be required for moving equipment.

3.1.2 Items in the package

These items are included in the package.

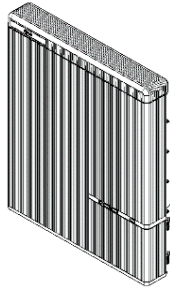

Battery pack

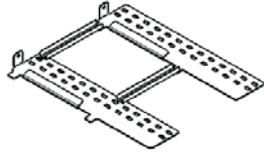

Wall bracket



M6 wall mount
bolts (2EA)



Manual



User Guide

3.1.3 Installation locations

Required :

- There must be no flammable or explosive materials nearby.
- The ambient temperature should be within the range of 14 ~ 113°F (-10 ~ 45°C).
- Battery pack must be installed on walls that are upright and can support battery weight.
- Product shall be installed in the order of: indoor (ex. basement or garage); or, outdoor but under the roof shades facing north; or, other sides of the house that minimizes direct sunlight.

Recommended :

- The building should be designed to withstand earthquakes.
- The waterproof and properly ventilated area is recommended. (IP55)
- Install the product on a flat wall.
- Install this product out of reach of children and animals.



CAUTION

If the ambient temperature is outside the operating range, the battery pack stops operating to protect itself. The optimal temperature range for the battery pack to operate is from 15°C to 30°C. Frequent exposure to harsh temperatures may deteriorate the performance and life of the battery pack.

3.1.4 Clearance

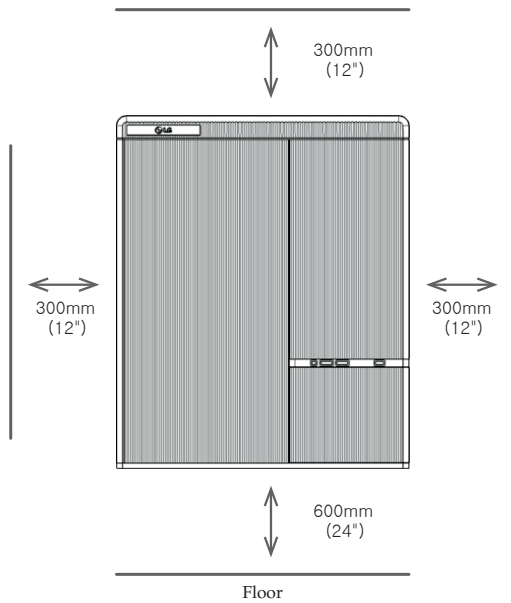

- Recommended clearances (>12") for the left, right, top and bottom of the product is shown in the figure for the proper ventilation and installer convenience.

3.1.5 Tools & safety gears required

- **Tools**

The following tools are required to install the battery pack :



Precision screwdriver

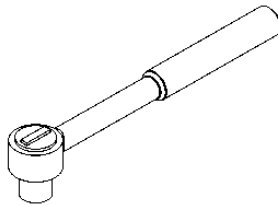

M6 Torque wrench

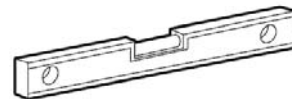

Inclinometer



Drill
(Min. Diameter 10mm, 0.4")



Pencil or Marker

- **Safety gears for personal protection**

It is recommended to wear the following safety gears when handling the battery pack.



Insulated gloves

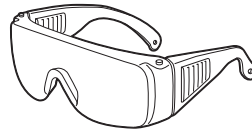

Safety goggles



Safety shoes

NOTE

RESU HV is heavy and challenging to lift. Lift handles are recommended.

Installation

To mount the battery pack on a wall, take the following steps :

1. Mark the location on the wall for the holes.
2. Drill holes for fasteners in the wall.
3. Drive the fasteners through the mounting bracket into the holes.

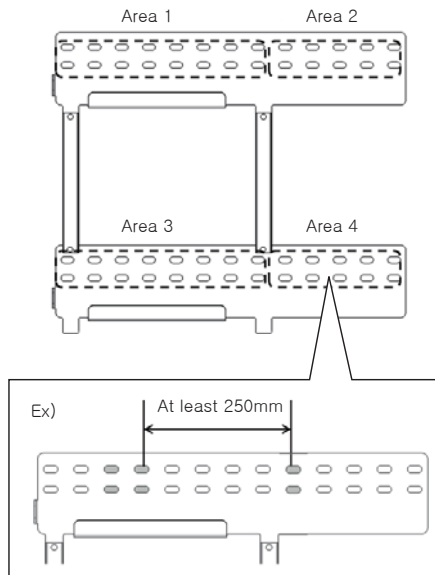

- Recommended diameter :
10mm(0.4") Min.
- Recommended length :
70mm(2.8") Min.
- Recommended material :
Stainless steel (8.8T)
- Minimum fastener count :
4(Area1) / 2(Area2) / 4(Area3) / 2(Area4)
- Vertically
- Minimum fastener clearance :
At least 250mm(10")
ex. Between Area 1's last fastener and
Area 2's first fastener

3.1.7 Appearance and dimension

- Appearance

Proper handling and care is recommended as disassembly, change of color, scratches, leakage of liquid, and stains may influence the economic value of the battery pack.

- Pack appearance and dimension

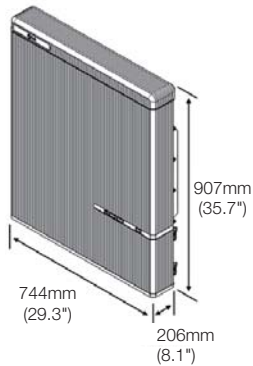

Color and Material

- Front / Rear Cover : Silver or Gold, Aluminum
- Top / Bottom / LED Cover : Black, Plastic

3.1.8 System clearance

Battery requires adequate clearance for installation, cabling and airflow. Minimum clearance in the system configuration is as follows.

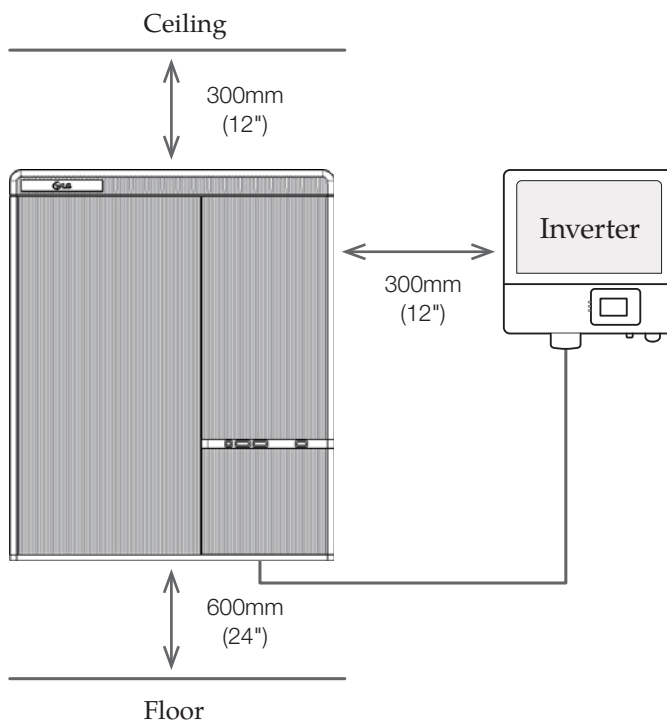

3.1.9 Installing the battery pack

⚠ CAUTION

Make sure that the inverter AC and DC disconnects are turned off before connecting the power cable to the battery pack.

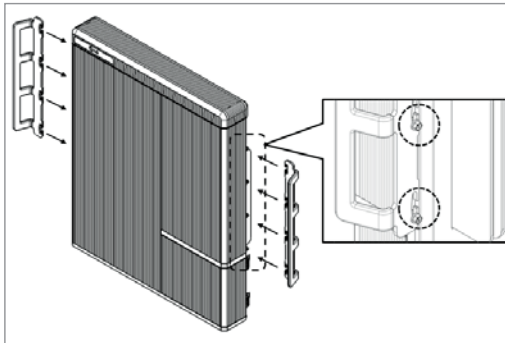

1. Fix the lift handles to the hex-socket screws on the rear (marked position) of both left and right sides.

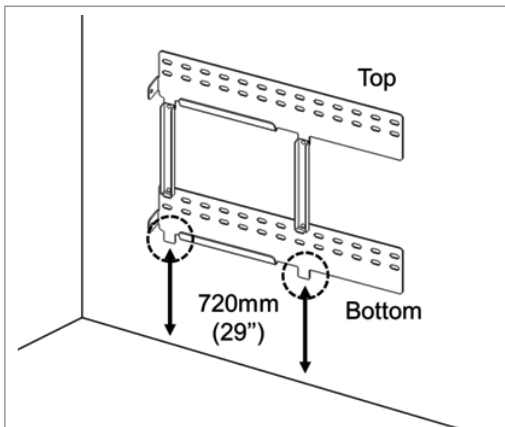

2. Mount the wall bracket to a wall. Tighten the screws, ensuring that they are horizontally driven into the wall. (Must be installed with recommended clearances(720mm[29"]) on the edge of the wall bracket as shown in the figure)

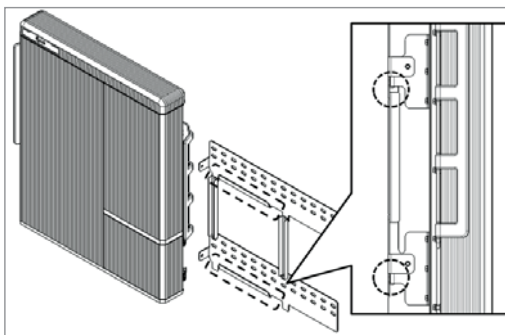

3. Mount the battery pack to a wall bracket's "U" shape clip using the support by lift handles. Remove the lift handles.

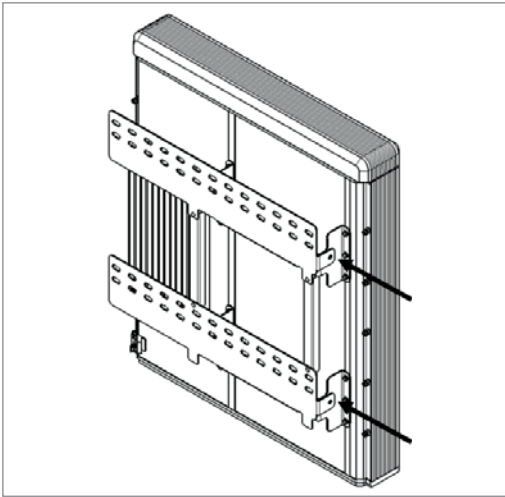

4. Tighten the two hex-socket screws enclosed and remove the lift handles. The nuts for these screws are welded to the battery pack chassis. Tighten to a torque of 5 N·m using the M6 torque wrench.

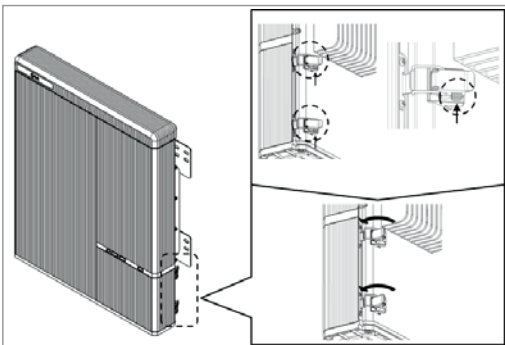

5. Press the two buttons and pull the two latches (marked position) on the rear side of the wiring box cover (hinged door).

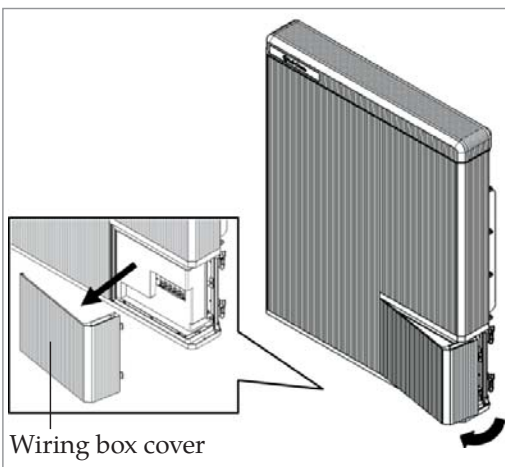

6. Open the wiring box cover (about 2~10 degrees), and pull to remove it.

⚠ CAUTION

The wiring box cover is heavy. [approx. 1.6kg(3.5lb)] If dropped it may cause injury.

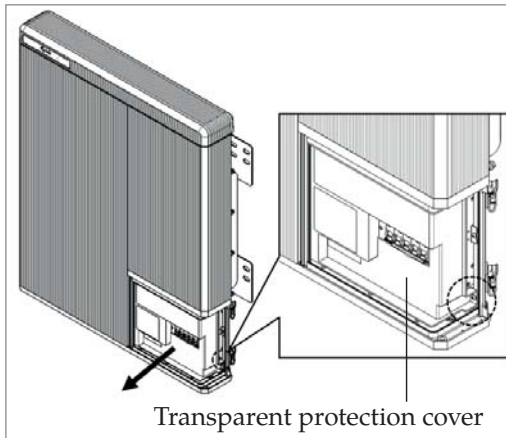

7. Loosen the screw (marked position), and remove the transparent protection cover.

⚠ CAUTION

If you lose or break a protection cover, that violates NEC Regulation.

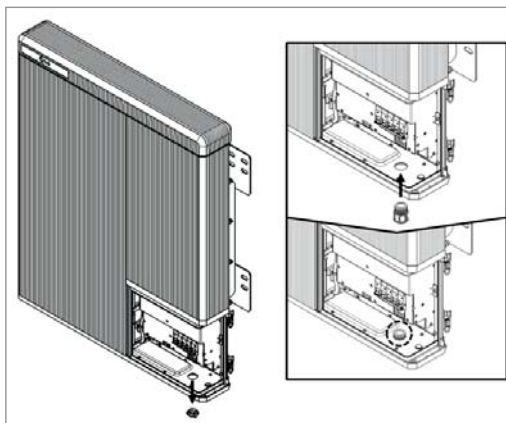

8. Remove the cap on hole in the bottom side, and assemble the 3/4" conduit plug. In the case outdoor, it must be sealed to comply "IP55" [ex] gasket, sealing foam, silicon, etc], where the battery pack installation is outdoor.

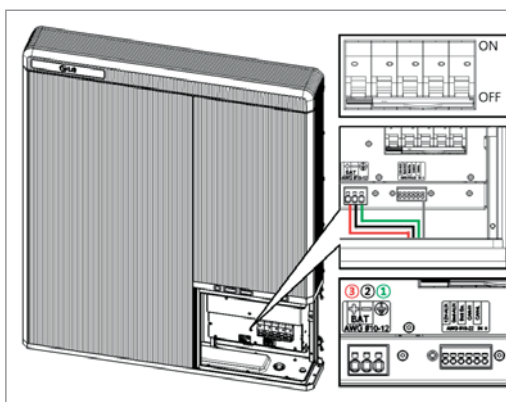

9. Connection Power / Communication cables, according to the labels marked.

3.2 Cable connection

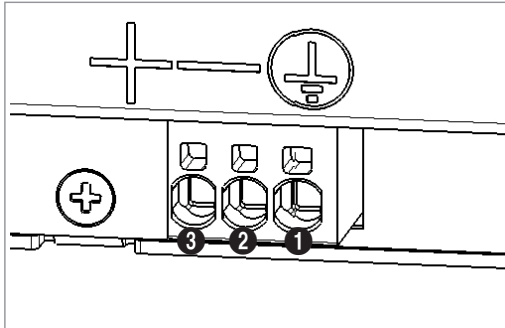

1. Power (wire AWG, Max length, Pinning)

a) Connect the ground wire to terminal 1.

b) Connect the negative line of the power cable to terminal 2.

c) Connect the positive line of the power cable to terminal 3.

※ For the specifications of the terminal block, see section 3.2.1 Auxiliary power switch and Spring Terminal blocks.

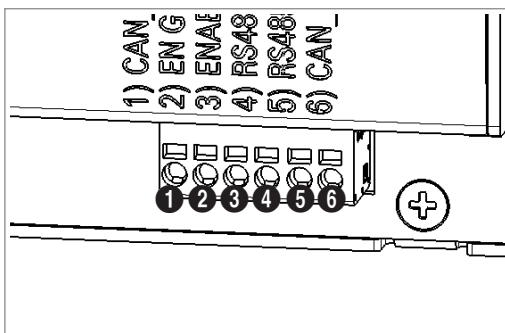

2. Communication (wire AWG, Max length, Pinning)

At first, connect the ground wire to terminal 2. Then, make connections to the other terminals one after another.

※ For the specifications of the terminal block, see section 3.2.1 Auxiliary power switch and Spring Terminal blocks.

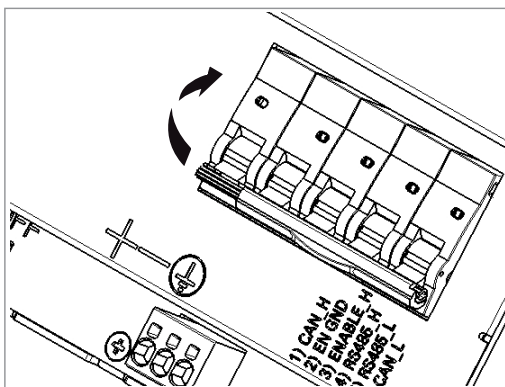

3. Connecting the battery pack to the inverter.

Refer to the installation instructions for the inverter to connect the power cable and communication cable to the inverter.

Then, push the circuit breaker switch up so that it is in the ON position.

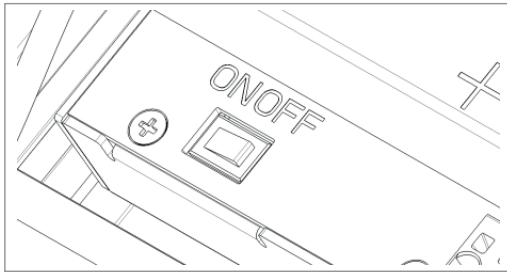

4. Auxiliary power ON/OFF switch (for shipping and storage)
Turn on the auxiliary power switch.
※ Must turn off to reduce self-discharge of battery during shipping and storage.

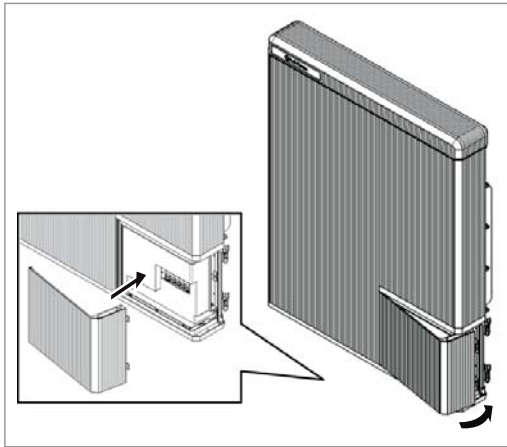

5. Close the transparent protection cover and tighten the screw. (Marked position)
Close the wiring box cover.
Reattach battery over the two latches on the rear.

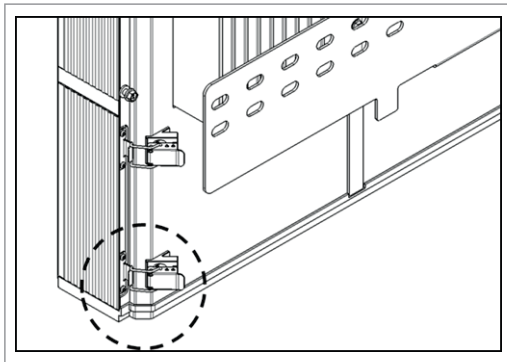

6. Hang the User Guide onto the latch on the rear of the battery.

※ Connect/disconnect the wire to connector sequence

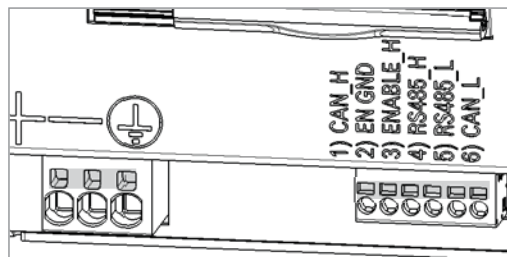

1. To remove one of the wires from its terminal, insert a small screwdriver into the rectangular hall above the terminal.
2. Apply slight pressure to the screwdriver and at the same time pull out the wire.

3.2.1 Auxiliary power switch and spring terminal blocks

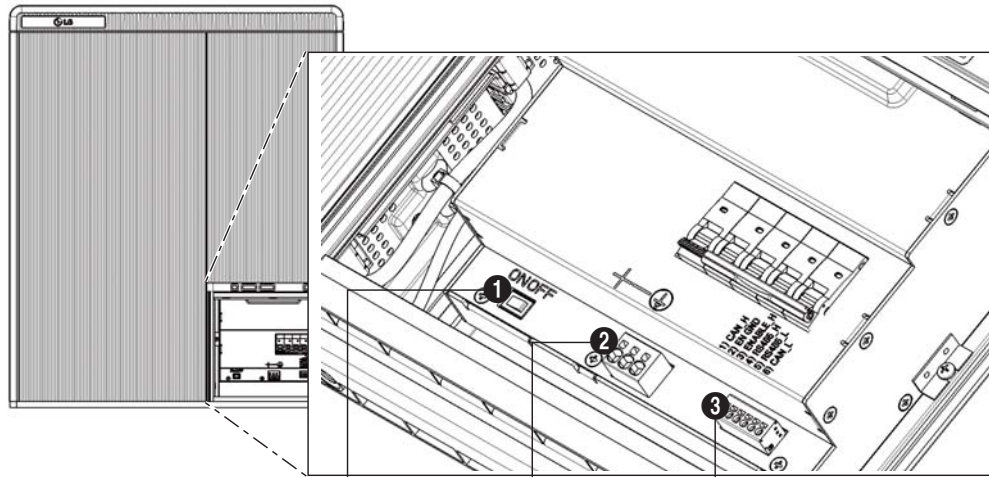

Auxiliary power switch — Power terminal block — Communication terminal block

1. Auxiliary power switch

- SPG-Electronics
- Rocker Switch
- SPG-R36

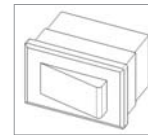

2. Power terminal block

- Max cable length: 10m (35ft)
- Cable Type : 4~10mm² (8~12AWG)
- DC 600V insulatedz
- Pinning
- Phoenix Contact
- PCB Terminal Block SPT
5/3-V-7,5-ZB
- P/N : 1719325

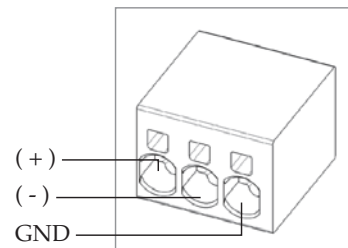

3. Communication terminal block

- Max cable length: 10m (35ft)
- Cable Type : 0.2~1.5mm² (18~24AWG)
- Pinning
- Phoenix Contact
- PCB Terminal Block SPT
2,5/6-V-5,0
- P/N : 1991134

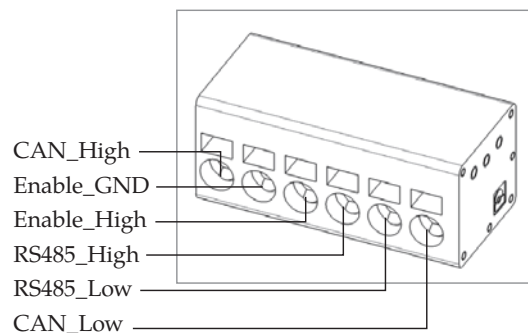



4 Commissioning

4.1 LED indicators

The LED indicators on the front of the battery pack show its operational state as follows:

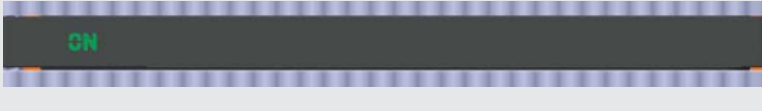
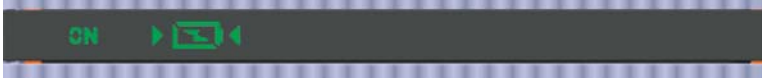
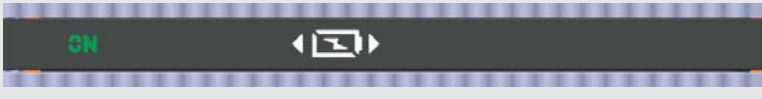

LED Status	Action
	Power on, Idle
	Charging
	Discharging
	Fault

There are four LED indicators on the front of the battery packs to show its operating status.

ON: This indicator stays on while the battery pack is charging.

Charging: This stays on while the battery pack is charging.

Discharging: This stays on while the battery pack is discharging.

FAULT: This comes on when the battery pack is in a warning state.

See Troubleshooting on page 29

4.2 Powering up battery pack

Put the battery pack in operation by taking the following steps :

1. Turn on the Auxiliary power ON/OFF switch after installation battery pack. Make sure that the Circuit Breaker switch is in the OFF position. (including Trip position)
2. Move the Circuit Breaker switch to the ON position.
3. Seconds after the Circuit Breaker switch is ON, 4 LEDs will be lit.
4. Make sure that ON indicator is on and see if the battery pack is successfully initialized. The power on indicator on the front should turn on in green.
5. Turn on the inverter.

CAUTION

If it stays off, indicates FAULT or fails to operate, do not use the battery pack and contact LG Chem (page 32) or your distributor.

4.3 Shutting off the battery pack

To shut down the battery pack, follow these steps :

1. Turn off the inverter.
2. Remove the wiring box cover.
3. Turn off the battery pack by moving the Circuit Breaker switch to the OFF position.
4. Make sure that every indicator on the battery pack is off. It should take 60 seconds at most for the indicators to turn off.
5. Turn off the Auxiliary Power ON/OFF switch.
6. Replace the inner cover and wiring box cover.

WARNING

Do not turn off the Auxiliary Power ON/OFF switch at normal operation mode such as charge and discharge mode.

If not using the battery pack for a long time or there is any fault on the battery pack, turn off the Auxiliary Power ON/OFF switch.

5 Troubleshooting

5.1 Troubleshooting

Check the indicators on the front to determine the state of the battery pack. A warning state is triggered when a condition, such as with voltage or temperature, is beyond design limitations. The battery pack's BMS periodically reports its operating state to the inverter.

When the battery pack falls outside prescribed limits, it enters a warning state. When a warning is reported, the inverter immediately stops operation.

Use the monitoring software on the inverter to identify what caused the warning. The possible warning messages are as follows:

- Battery Over Voltage
- Battery Under Voltage
- Battery Over Temperature
- Battery Under Temperature
- Battery Discharge Over Current
- Battery Charge Over Current
- BMS Internal Communication
- Battery Cell Voltage Imbalance

The abnormal state is cleared when the battery pack recovers normal operation. If battery pack is not working correctly and the issue persists, contact a Qualified personnel, Installer or LG Chem.

NOTE

For a serious warning, if no proper corrective actions are taken by the inverter, the battery pack's circuit breaker automatically trips to protect itself.

CAUTION

If the battery pack or the inverter indicates FAULT or fails to operate, contact LG Chem (page 32) or your distributor immediately.

6 Uninstallation & Return

6.1 Return/replacement instructions

6.1.1 Uninstallation from the wall

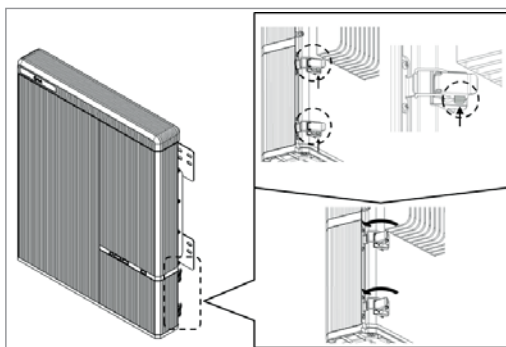

1. Switch OFF the Inverter before starting the uninstallation of the battery pack.
2. Press the two buttons and pull the two latches (marked position) on the rear.

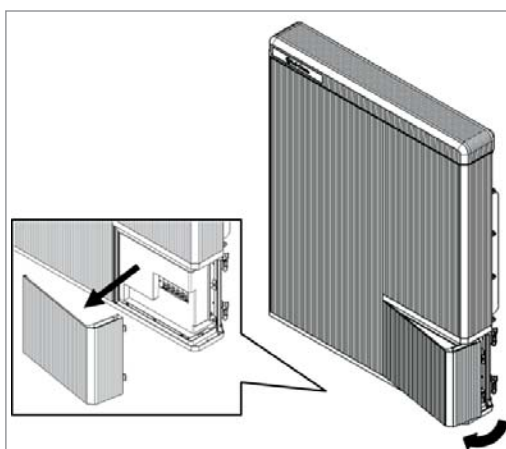

3. Open the wiring box cover (about 2~10 degrees), and pull to remove it.

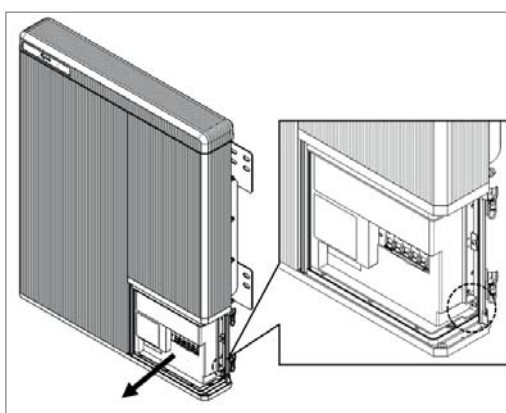

4. Loosen the screw (marked position), and remove the transparent protection cover.

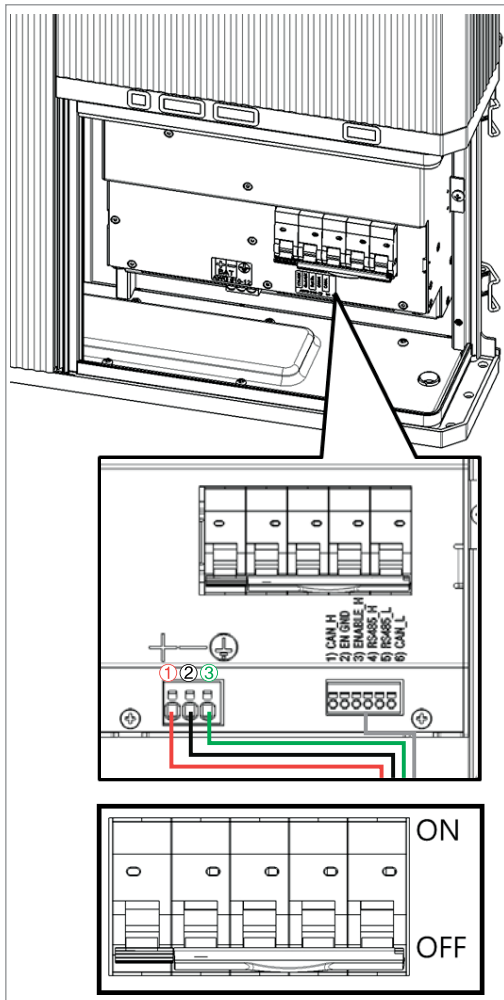

- Switch off the circuit breaker.

※ If you have Auxiliary Power ON/OFF switch, turn off Auxiliary Power switch.

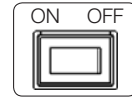

⚠ CAUTION

Do not turn off the Auxiliary Switch while the battery is in operation.

- Disconnect the communication cable from the communication port.
- Disconnect the power cable from the terminal block. Disconnect the positive terminal (+) ① first, and next the negative terminal (-) ②, and finally ground terminal ③.
- Assemble transparent protection cover. Close the wiring box cover, and lock the ratchet.

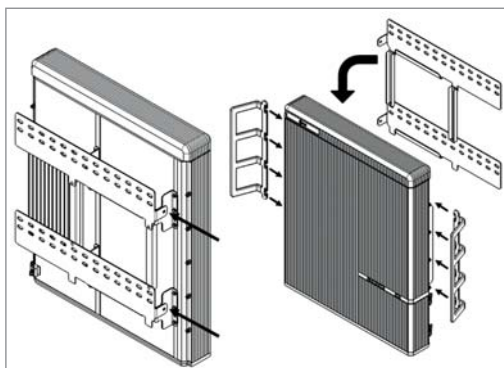

- Loosen the two hex-socket screws using a socket wrench to detach the battery pack from the wall using lift handles.

⚠ CAUTION

According to regional regulations, several people may be required for moving equipment.

6.1.2 Contact information

Damaged batteries are dangerous and must be handled with extreme caution. They are not fit for use and may pose a danger to people or property. If the battery pack seems to be damaged, contact LG Chem or your distributor.

Use the contacts below for technical assistance. These phone numbers are available only during business hours on weekdays.

Contact Information		
HQ (KOR)	Address	29, Gwahaksaneop-3-ro, Oksan-myeon, Heungdeok-gu, Cheongju-si , Chungcheongbuk- do, South Korea
	Telephone	+82 43 219 2695
	Email	Soongkyu@lgchem.com
US	Address	1064 Chicago Rd, Troy, MI 48083, USA
	Telephone	+1 248 808 0016
	Email	CSNorthAmericaESS@lgchem.com
Europe	Address	Otto-Volger Str. 7C 65843 Sulzbach (Taunus),Germany
	Telephone	+49 162 297 0918
	Email	aburkert@lgchem.com
Australia	Address	3/6 Pelle St Mitchell ACT 291
	Telephone	+61 1300 18 064
	Email	m_AUservice@lgchem.com
Other Regions	Address	29, Gwahaksaneop-3-ro, Oksan-myeon, Heungdeok-gu, Cheongju-si , Chungcheongbuk- do, South Korea
	Telephone	+82 43 219 2695
	Email	Soongkyu@lgchem.com



Keep this manual for later use.

© 2016 LG Chem
FKI Tower 37th, 24, Yeoui-daero, Yeongdeungpo-gu, Seoul 07320, Rep. of KOR.
TEL : (82) 2-3773-1114 FAX : (82) 2-3773-7005
<http://www.lgesspartner.com> <http://www.lgchem.com>

