

# TILT MOUNT

INSTALLATION MANUAL

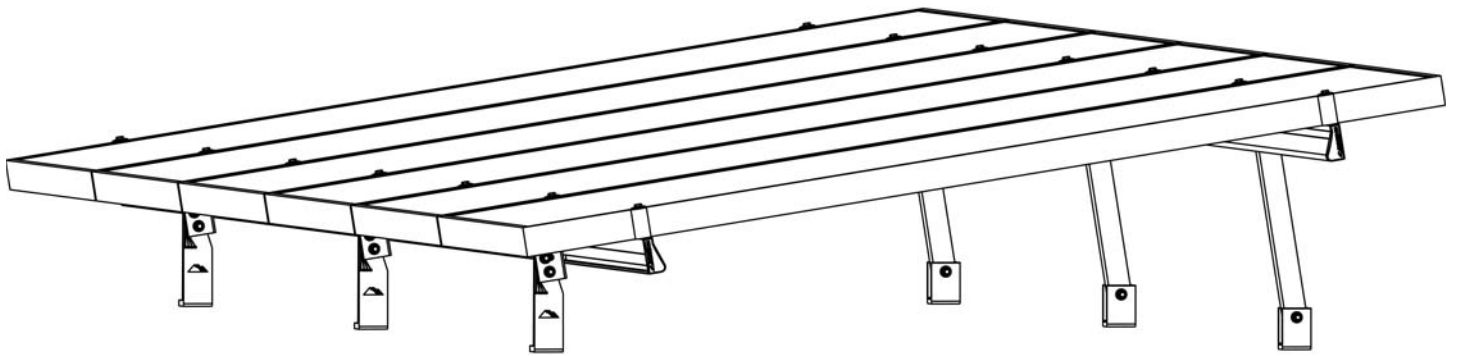

IRONRIDGE



# CONTENTS

<b>DISCLAIMER</b>	<b>1</b>
<b>RATINGS</b>	<b>2</b>
<b>MARKINGS</b>	<b>2</b>
<b>CHECKLIST</b>	<b>3</b>
<b>1. ATTACH BASES</b>	<b>4</b>
<b>2. ADD TILT LEGS</b>	<b>4</b>
<b>3. PLACE RAILS</b>	<b>5</b>
<b>4. SECURE LUGS</b>	<b>5</b>
<b>5. SECURE MODULES</b>	<b>6</b>
<b>EXPANSION JOINTS</b>	<b>7</b>
<b>ELECTRICAL DIAGRAM</b>	<b>7</b>
<b>ELECTRICAL DIAGRAM (CONTINUED)</b>	<b>8</b>
<b>END CAPS</b>	<b>8</b>
<b>WIRE CLIPS</b>	<b>8</b>
<b>MICROINVERTER KITS</b>	<b>9</b>
<b>SYSTEMS USING ENPHASE MICROINVERTERS</b>	<b>9</b>
<b>MODULE COMPATIBILITY</b>	<b>10</b>
<b>WARRANTY</b>	<b>11</b>

## DISCLAIMER

This manual describes the proper installation procedures and provides minimum standards required for product reliability and warranty. Thoroughly understanding this manual is imperative to proper installation; failure to follow the guidelines set forth can result in property damage, bodily injury, or even death.

### IT IS THE INSTALLER'S RESPONSIBILITY TO:

- All electrical installation and procedures should be conducted by a licensed and bonded electrician. Routine maintenance of a module or panel shall not involve breaking or disturbing the bonding path of the system.
- Comply with all applicable local or national building and fire codes, including any that may supersede this manual.
- Ensure all products are appropriate for the installation, environment, and array under the site's loading conditions.
- Use only IronRidge parts or parts recommended by IronRidge; substituting parts may void any applicable warranty.
- Review the [Design Assistant](#), [Engineering Design Guide](#), and [Certification Letters](#) to confirm design specifications.
- Refer to IronRidge's Structural Certification Letters for state specific design conditions including allowable rail spans, cantilever length, and splice location requirements.
- Comply with all applicable fire codes including, but not limited to, keeping walkways clear and avoiding obstacles.
- Ensure provided information is accurate. Issues resulting from inaccurate information are the installers' responsibility.
- Ensure bare copper grounding wire does not contact aluminum and zinc-plated steel components, to prevent risk of galvanic corrosion.
- If loose components or loose fasteners are found during periodic inspection, re-tighten immediately. If corrosion is found, replace affected components immediately.
- Provide an appropriate method of direct-to-earth grounding according to the latest edition of the National Electrical Code, including NEC 250: Grounding and Bonding, and NEC 690: Solar Photovoltaic Systems.
- Disconnect AC power before servicing or removing microinverters and power optimizers.

## RATINGS

### UL 2703 LISTED



#5003339

**Intertek**

- Conforms to ANSI/UL 2703 (2015) Standard for Safety First Edition: Mounting Systems, Mounting Devices, Clamping/Retention Devices, and Ground Lugs for Use with Flat-Plate Photovoltaic Modules and Panels
- Max Overcurrent Protective Device (OCPD) Rating: 25A
- Max Module Size: 24ft<sup>2</sup>
- Module Orientation: Portrait or Landscape
- Mechanical Load Rating: meets minimum requirements of the standard (10 PSF downward, 5 PSF upward, 5 PSF lateral). Actual system structural capacity is defined by PE stamped [certification letters](#).

### CLASS A SYSTEM FIRE RATING PER UL 1703

- Any System Tilt with Modules Types 1, 2 & 3 on Low Slope Roofs (< 9.5 degrees)
- Any System Tilt with Module Types 1 & 2 on Steep Slope Roofs (> 9.5 degrees)
- Any module-to-roof gap is permitted, with no perimeter guarding required. This rating is applicable with any third-party attachment.
- Class A rated PV systems can be installed on Class A, B, and C roofs without affecting the roof fire rating.

### STRUCTURAL CERTIFICATION

- Designed and Certified for Compliance with the International Building Code & ASCE/SEI-7

## MARKINGS

Product markings are located on the South Tilt Leg.

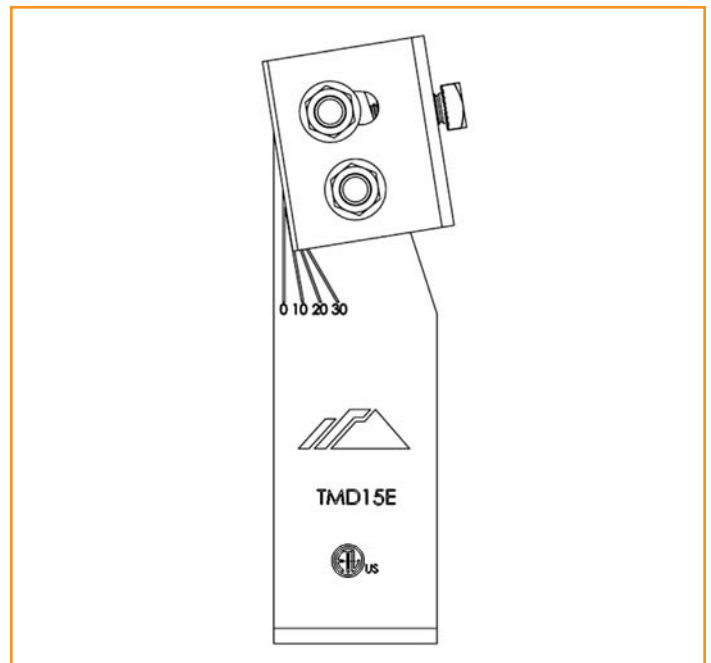

# CHECKLIST

## PRE-INSTALLATION

- Verify module compatibility. See [Page 10](#) for info.

## TOOLS REQUIRED

- Cordless Drill (non-impact)
- Impact Driver (for lag bolts)
- Torque Wrench (0-250 in-lbs)
- 5/16" Socket
- 7/16" Socket
- 3/8" Socket (deep)
- String Line

## TORQUE VALUES

- Tilt Leg Nuts (3/8" Socket): 250 in-lbs
- Bonded Splice Screws (5/16" Socket): 20 in-lbs
- Grounding Lug Nuts (7/16" Socket): 80 in-lbs
- Grounding Lug Terminal Screws (7/16 Socket): 20 in-lbs
- Universal Fastening Objects (7/16" Socket): 80 in-lbs
- Expansion Joint Nuts (7/16") : 80 in-lbs
- Microinverter Kit Nuts (7/16" Socket): 80 in-lbs

## IRONRIDGE COMPONENTS

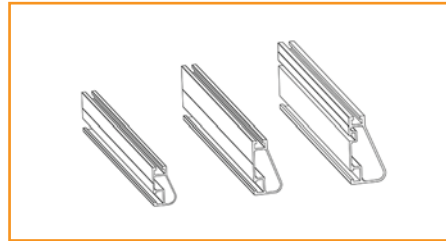

XR Rail

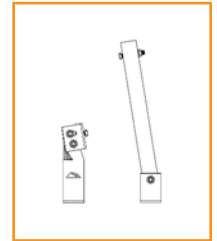

Tilt Leg Kit

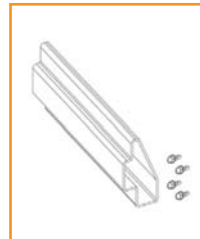

Bonded Splice

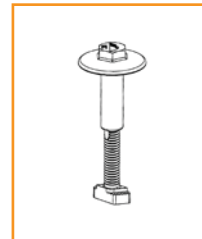

UFO



Stopper Sleeve

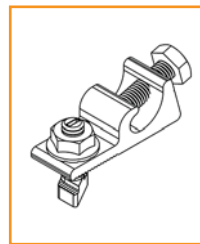

Grounding Lug

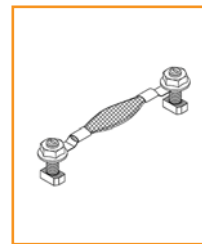

Expansion Joint



End Cap



Wire Clip

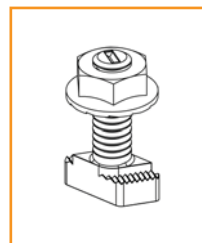

Microinverter Kit

💡 If using previous version of: Integrated Grounding Mid Clamps, Grounding Lug, End Clamps, and Expansion Joints please refer to Alternate Components Addendum version 1.0

# 1. ATTACH BASES

Mark locations for roof attachments and attach per manufacturer's instructions.

💡 **Tested or evaluated third-party roof attachments:**

- [Anchor Products - U-Anchor](#)
- [S-5! Standing Seam Metal Roof Clamps](#) - Certification of metal roof clamps includes bonding to both painted and galvalume metal roofs. Tighten clamp set screws to 130-150 in-lbs ( $\geq 24$  gauge) or 160-180 in-lbs (22 gauge) roofs. Tighten S-5! M10 bolt to 240 in-lbs or S-5! Mini M8 bolt to 156 in-lbs.
- [QuickMount PV Tilt Standoffs](#) - QMNC, QMLSH; Tighten 5/16" bolt on top of standoff to a minimum of 140 in-lbs.

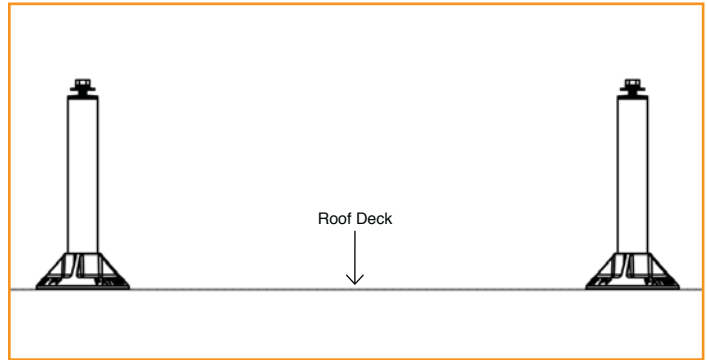

# 2. ADD TILT LEGS

## A. ASSEMBLE SOUTH LEGS

Mount South Tilt Leg Assembly to southern row of roof attachments. The IronRidge logo should face east to ensure proper South Leg orientation. Tighten assembly per roof attachment manufacturer's instructions.

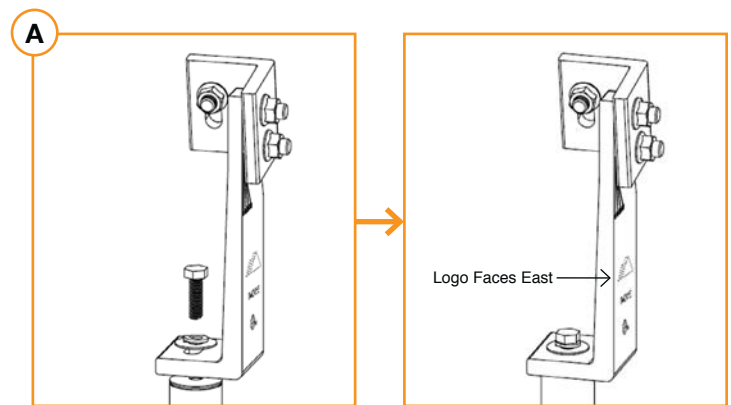

## B. SET ANGLE

Set top pivot bracket of South Tilt Leg to the desired angle using the angle indicator on the face of the leg. Finger tighten bolts to allow for adjustment if necessary.

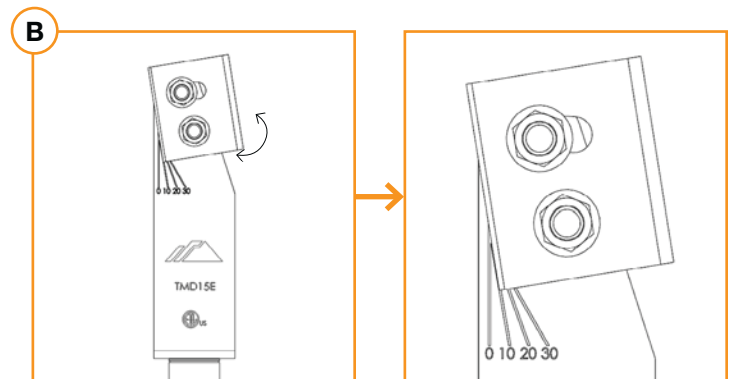

## C. ASSEMBLE NORTH LEGS

Mount U-foot to northern row of roof attachments. Tighten U-foot to attachment per manufacturer's instructions. Mount North Tilt Leg to northern row of U-feet and loosely secure hardware.

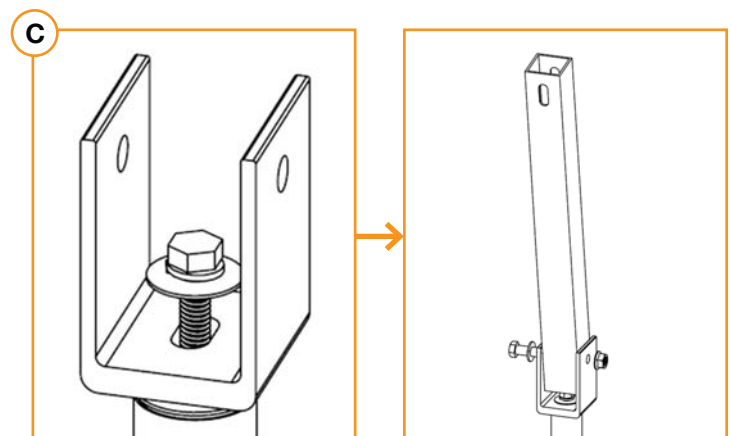

## 3. PLACE RAILS

### A. CONNECT SPLICES

Use Bonded Splices, when needed, to join multiple sections of rail. Insert Bonded Splice 6" into first rail and secure with two self-drilling screws, spacing them about 1" apart and torquing to **20 in-lbs**. Slide second rail over Bonded Splice and secure with two self-drilling screws.

- 💡 Rows exceeding 100 feet of rail must use [Expansion Joints](#).
- 💡 For XR10 and XR100 rails, insert screws along the provided lines.
- 💡 Refer to Structural Certification letters for rail splice location requirements.
- 💡 Screws can be inserted on front or back of rails.
- 💡 If using Bonding Bolt Splices, refer to addendum (v1.0).

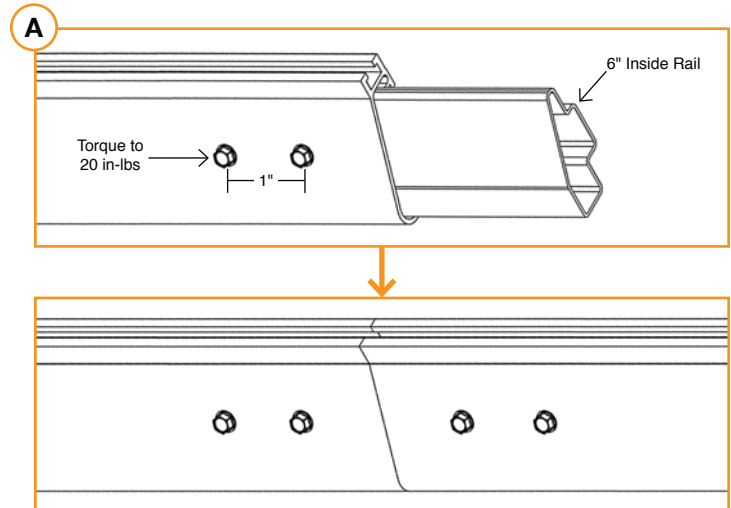

### B. ATTACH SOUTH RAILS

Slide 1" long bonding bolt into side-facing rail slot. Mount rail to pivot bracket of South Legs and loosely tighten nuts.

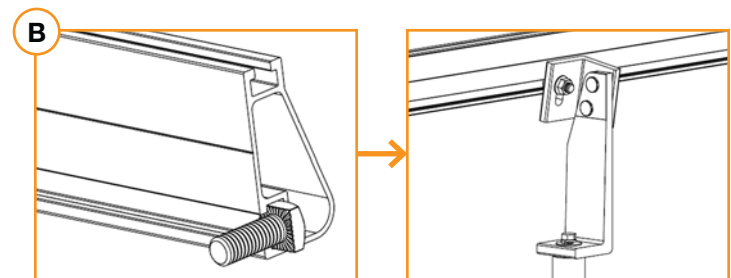

### C. ATTACH NORTH RAILS

Slide 2.25" bonding bolt into side-facing rail slot. Mount rail to top of North Legs. Tighten all 3/8" hardware to **250 in-lbs** once rails are square.

- 💡 Use a straight edge to ensure South and North rails are on the same plane. An extra section of rail works well.
- 💡 Rails can mount on either north or south side of North Tilt Leg.

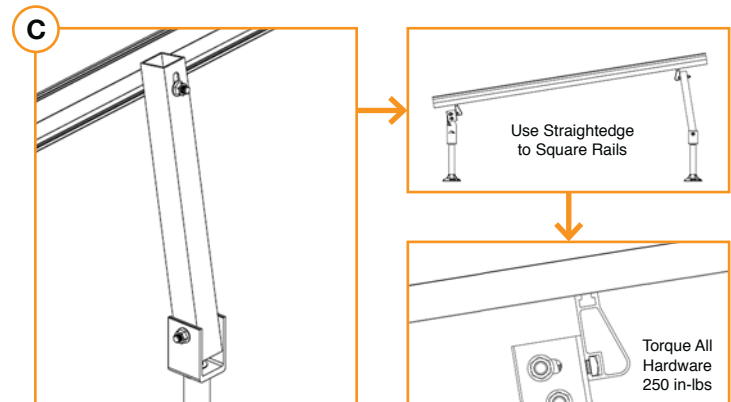

## 4. SECURE LUGS

Insert T-bolt in top rail slot and torque hex nut to **80 in-lbs**. Install a minimum 10 AWG solid copper or stranded grounding wire. Torque terminal screw to **20 in-lbs**.

- 💡 Grounding Lugs are only needed on one rail per row of modules.
- 💡 If using Enphase microinverters, Grounding Lugs may not be needed. See [Page 9](#) for more information.
- 💡 Grounding Lugs can be installed anywhere along the rail and in either orientation shown.

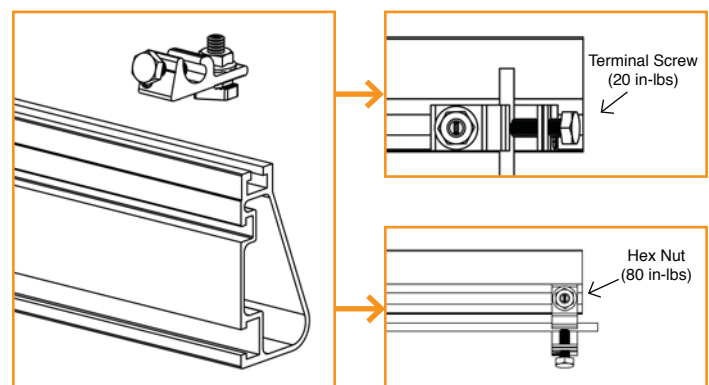

## 5. SECURE MODULES

### A. SECURE FIRST END

Place first module in position on rails, a minimum of 1" from rail ends. Snap Stopper Sleeves onto UFO. Fasten the module to the rail with the UFO, ensuring that the UFO is hooked over the top of the module. Torque to **80 in-lbs**.

💡 Ensure rails are square before placing modules.

💡 Hold Stopper Sleeves on end while torquing to prevent rotation.

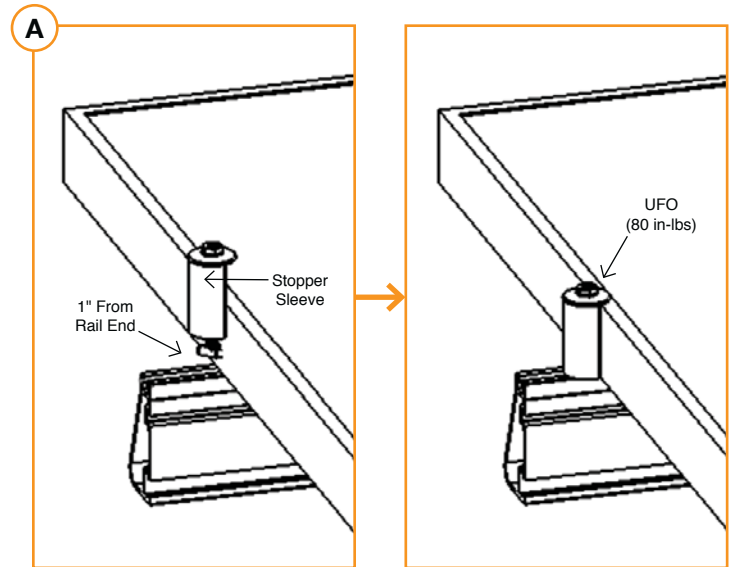

### B. SECURE NEXT MODULES

Place UFO into each rail, placing them flush against first module. Slide second module against the UFO. Torque to **80 in-lbs**. Repeat for each following module.

💡 When reinstalling UFO, move modules a minimum of 1/16" so UFOs are in contact with a new section of module frame.

💡 If using Wire Clips, refer to [Page 8](#).

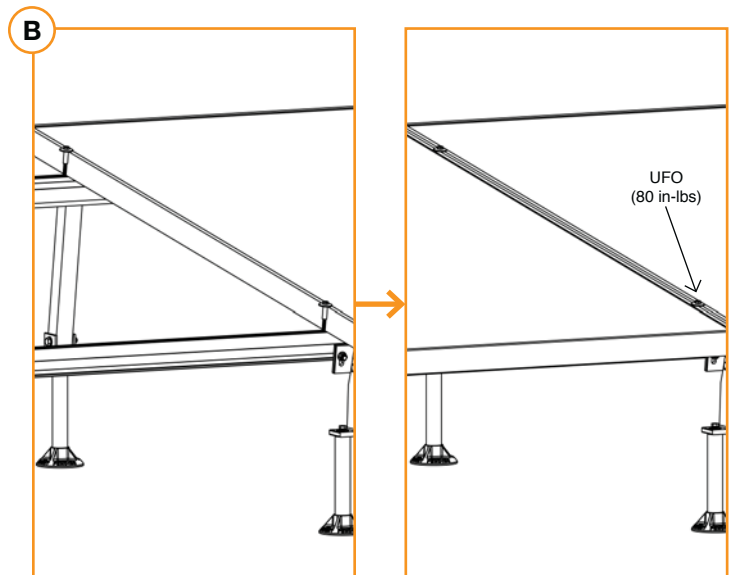

### C. SECURE LAST END

Place last module in position on rails, a minimum of 1" from rail ends. Snap Stopper Sleeves onto UFO. Secure UFO on rail, ensuring it is hooked over the top of the module. Torque to **80 in-lbs**.

💡 Hold Stopper Sleeves on end while torquing to prevent rotation.

💡 Repeat all steps for each following row of modules.

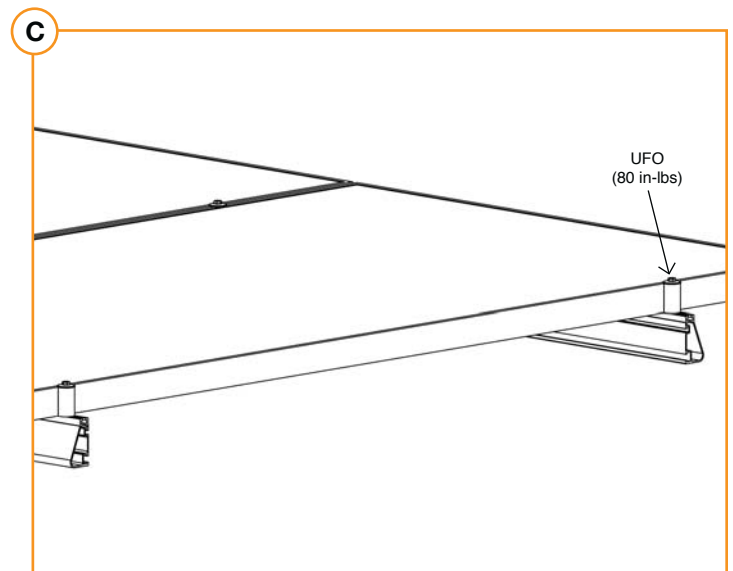

## EXPANSION JOINTS

### GROUNDING STRAP EXPANSION JOINT

Grounding Strap Expansion Joints are required for thermal expansion of rows exceeding 100 feet of rail.

Insert Bonded Splice into first rail and secure with one screw. Assemble and secure Grounding Strap 3/8" from rail end. Slide second rail over Bonded Splice leaving 1" gap between rails. Attach other end of Grounding Strap with hardware, and torque hex nuts to **80 in-lbs**.

💡 Remaining Bonded Splice screws are not used with Expansion Joints.

💡 Do not install module over top of expansion joint location.

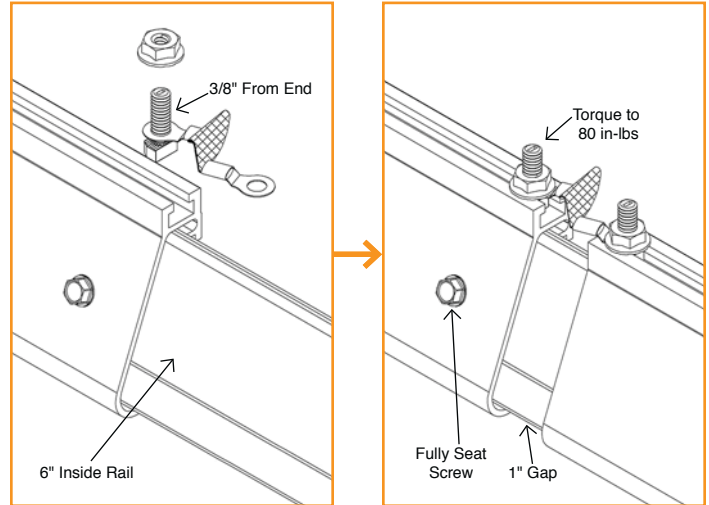

## ELECTRICAL DIAGRAM

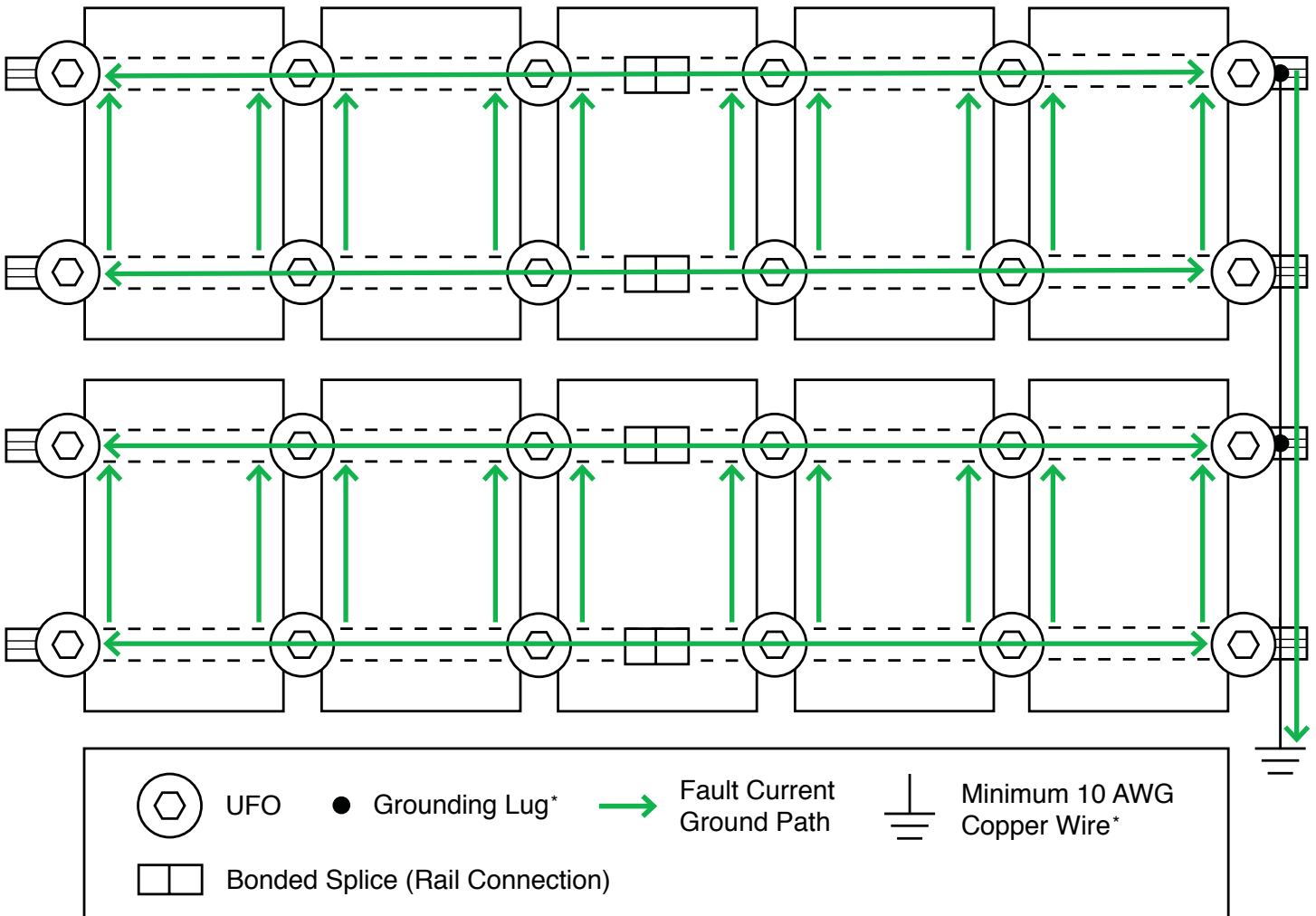

\*Grounding Lugs and Wire are not required in systems using Enphase microinverters.



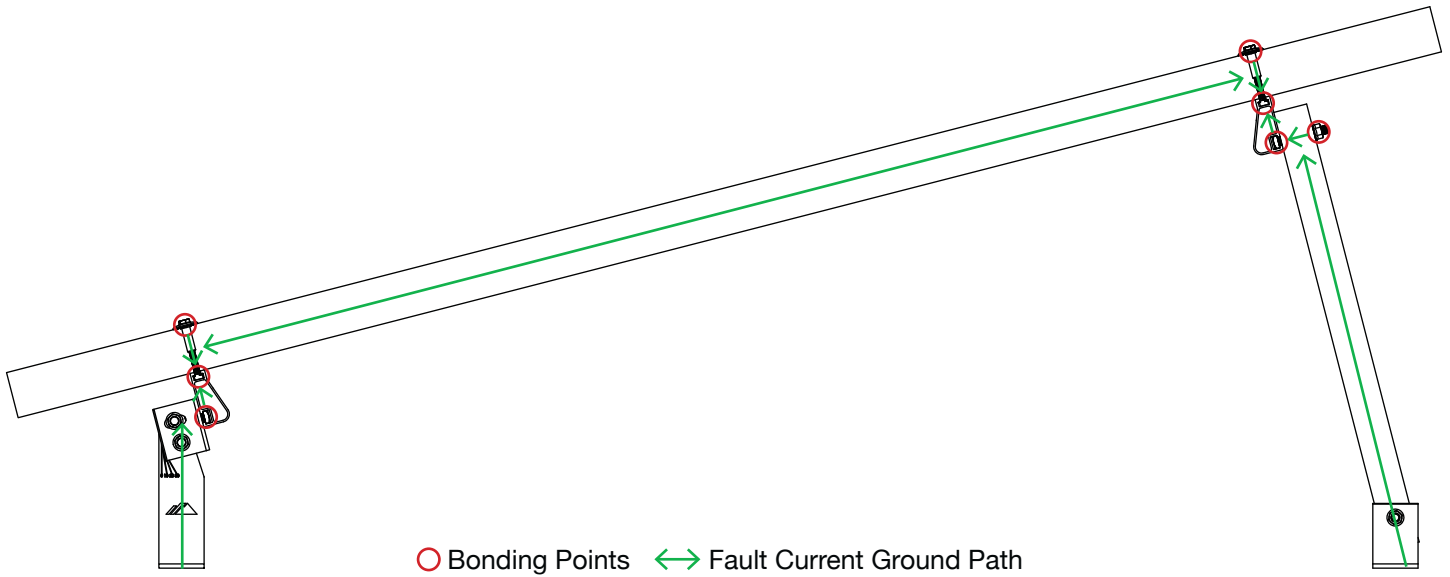

## END CAPS

End Caps add a completed look and keep debris and pests from collecting inside rail.

Firmly press End Cap onto rail end.

💡 End Caps come in sets of left and right. Check that the proper amount of each has been provided.

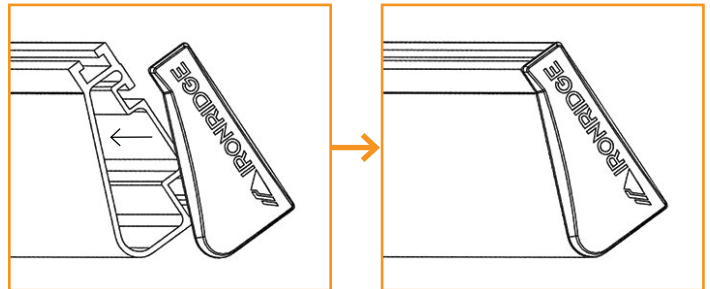

## WIRE CLIPS

Wire Clips offer a simple wire management solution.

Firmly press Wire Clip into top rail slot. Run electrical wire through open clip. Snap closed once all wires have been placed.

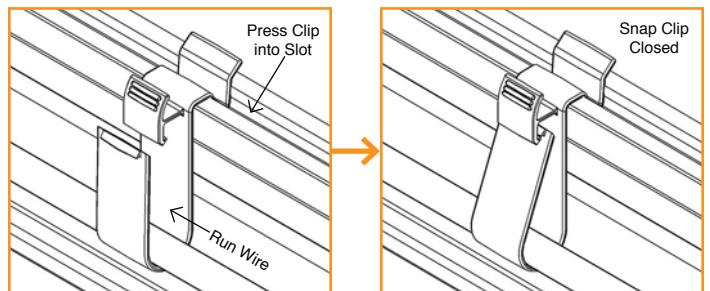

## MICROINVERTER KITS

Use IronRidge's Microinverter Kit to bond compatible microinverters and power optimizers to the racking system.

Insert Microinverter Kit T-bolt into top rail slot. Place compatible microinverter or power optimizer into position and tighten hex nut to **80 in-lbs**.

### COMPATIBLE PRODUCTS

Enphase - M250-72, M250-60, M215-60, and C250-72

Darfon - MIG240, MIG300, G320, G640

Solar Edge - P300, P320, P400, P405, P600, P700, P730

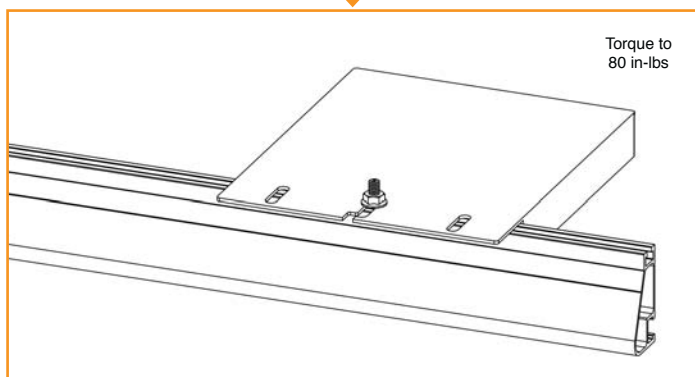
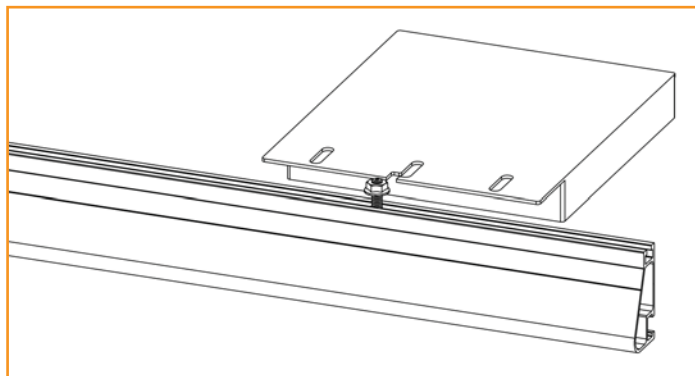

## SYSTEMS USING ENPHASE MICROINVERTERS

IronRidge systems using approved Enphase products eliminate the need for lay-in lugs and field installed equipment grounding conductors (EGC). This solution meets the requirements of UL 2703 for bonding and grounding and is included in this listing.

The following Enphase products are included in this listing: Microinverters M250-72, M250-60, M215-60, C250-72, and Engage cables ETXX-240, ETXX-208, ETXX-277.

💡 A minimum of two inverters mounted to the same rail and connected to the same Engage cable are required.

💡 The microinverters must be used with a maximum 20 A branch rated overcurrent protection device (OCPD).

## MODULE COMPATIBILITY

The Tilt Mount System may be used to ground and/or mount a PV module complying with UL 1703 only when the specific module has been evaluated for grounding and/or mounting in compliance with the included instructions. Unless otherwise noted, “xxx” refers to the module power rating and both black and silver frames are included in the certification.

MANUFACTURER	MODELS
Astronergy Solar	Modules with 35, 40, and 45mm frames and model identifier aaSM66yyPzz-xxx; where “aa” can be CH or A; “yy” can be either 10 or 12; “zz” can be blank or (BL).
Canadian Solar	Modules with 40mm frames and model identifier CS6Y-xxxZ; where “Y” can be K, P, V, or X; and “Z” can be M, P, PX, or P-SD.
ET Solar	Modules with 35, 40, and 50mm frames and model identifier ET-Y6ZZxxxAA; where “Y” can be P, L, or M; “ZZ” can be 60 or 72; and “AA” can be WB, WW, BB, WBG, WWG, WBAC, WBCO, WWCO, WWBCO or BBAC.
GigaWatt Solar	Modules with 40mm frames and model identifier GWxxxYY; where “YY” can be either PB or MB.
Hanwha Solar	Modules with 40, 45, and 50mm frames and model identifier HSLaaP6-YY-1-xxxZ; where “aa” can be either 60 or 72; “YY” can be PA or PB; and “Z” can be blank or B.
Hanwha Q CELLS	Modules with 32, 35, 40, and 42mm frames and model identifier Q.YY-ZZ-xxx; where “YY” can be PLUS, PRO, or PEAK; and “ZZ” can be G3, G4, L-G2, L-G3y, L-G4y, BFR-G3, BLK-G3, BFR-G4, BFR-G4.1, or G4.1/SC.
Hyundai	Modules with 35 and 50mm frames and model identifier HiS-YxxxZZ; where “Y” can be M or S; and “ZZ” can be MI, MF, MG, SG, RI, RG, TI, or TG.
JA Solar	Modules with 40 and 45mm frames and model identifier JAyyzz-bb-xxx/aa; where “yy” can be M6 or P6; “zz” can be blank, (K), (L), (R), (V), (BK), (FA), (TG), (FA)(R), (L)(BK), (L)(TG), (R)(BK), (R)(TG), (V)(BK), (BK)(TG), or (L)(BK)(TG); “bb” can be 48, 60, or 72; and “aa” can be MP, SI, PR, 3BB, 4BB, 4BB/RE.
Jinko	Modules with 35 and 40mm frames and model identifier JKMYxxxZZ; where “Y” can either be blank or S; and “ZZ” can be M, P, PP, P-B, or P-V.
Kyocera	Modules with 46mm frames and model identifier KYxxxZZ-AA; where “Y” can be D or U; “ZZ” can be blank, GX, or SX; and “AA” can be LPU, LFU, UPU, LPS, LPB, LFB, LFBS, LFB2, LPB2, 3AC, 3BC, 3FC, 4AC, 4BC, 4FC, 4UC, 5AC, 5BC, 5FC, 5UC, 6BC, 6FC, or 8BC.
LG	Modules with 35, 40, and 46mm frames and model identifier LGxxx1z-bb; where “y” can be A, N, or S; “z” can be C or K; and “bb” can be A3, B3, G3, C4 or K4.
Mistubishi	Modules with 46mm frames and model identifier PV-MYYxxxZZ; where “YY” can be LE or JE; and “ZZ” can be either HD, HD2, or FB.
Motech	IM and XS series modules with 40, 45, and 50mm frames.
Panasonic	Modules with 35mm frames and model identifier VBHNxxxSAyy; where “yy” can be either 06, 06B, 11, 11B, 15, 15B, 16 or 16B.
Phono Solar	Modules with 35, 40, and 45mm frames and model identifier PSxxxY-ZZ/A; where “Y” can be M or P; “ZZ” can be 20 or 24; and “A” can be F, T or U.
REC Solar	Modules with 38 and 45mm frames and model identifier RECxxxYYZZ; where “YY” can be M, PE or TP; and “ZZ” can be blank, BLK, SLV, or 72.
Renesola	Modules with 35, 40 and 50mm frames and model identifier JCxxxY-ZZ; where “Y” can be F, M or S; and “ZZ” can be Ab, Ab-b, Abh, Abh-b, Abv, Abv-b, Bb, Bb-b, Bbh, Bbh-b, Bbv, Bbv-b, Db, or Db-b.
SolarWorld	Sunmodule Plus, Protect or XL mono or poly modules with 31, 33 or 46mm frames and model identifier SW-xxx.
Stion	Thin film modules with 35mm frames and model identifier STO-xxx.
SunEdison	Modules with 35, 40, and 50mm frames and model identifier SE-YxxxZABCDE; where “Y” can be B, F, H, P, R, or Z; “Z” can be 0 or 4; “A” can be B, C, D, E, H, I, J, K, L, M, or N; “B” can be B or W; “C” can be A or C; “D” can be 3, 7, 8, or 9; and “E” can be 0, 1 or 2.
Suniva	Modules with 35, 38, 40, 46, and 50mm frames and model identifiers OPTxxx-AA-B-YYY-Z or MVXxxx-AA-B-YYY-Z; where “AA” is either 60 or 72; “B” is either 4 or 5; “YYY” is either 100,101,700,1B0, or 1B1; and “Z” is blank or B.
Sunpower	SPR-A-xx series with standard (G3) or InvisiMount (G5) 46mm frames; where “A” is either E or X; and “xx” is the series number.
Suntech	Vd, Vem, Wdb, Wde, and Wd series modules with 35, 40, and 50mm frames.
Trina	Modules with 35, 40 and 46mm frames and model identifier TSM-xxxYYZZ; where “YY” can be PA05, PC05, PD05, PA14, PC14, or PD14; and “ZZ” can be blank or A or A.05 or A.08.
Winaico	Modules with 35 and 40mm frames and model identifier Wsy-xxxz6; where “y” can be either P or T; and “z” can be either M or P.
Yingli	Panda, YGE, and YGE-U series modules with 35, 40, and 50 mm frames.

## WARRANTY

Effective for Products manufactured after April 1st, 2012, IronRidge provides the following warranties, for Products installed properly and used for the purpose for which the Products are designed:

(a) Products with finishes (ie excluding without limitation Products that are mill finished) shall be free of visible defects, peeling, or cracking, under normal atmospheric conditions, for a period of three years from the earlier of (i) the date of complete installation of the Product or (ii) 30 days after the original purchaser's date of purchase of the Product ("Finish Warranty"); (b) components shall be free of structurally-related defects in materials for a period of ten years from the earlier of (i) the date of complete installation of the Product or (ii) 30 days after the original purchaser's date of purchase of the Product; and (c) components shall be free of functionally-related manufacturing defects for a period of 20 years from date of manufacture.

The Finish Warranty does not apply to: (d) surface oxidation of the galvanized steel components or any foreign residue deposited on Product finish; and (e) Products installed in corrosive atmospheric conditions, as defined solely by IronRidge; corrosive atmospheric conditions include, but are not limited to, conditions where Product is exposed to corrosive chemicals, fumes, cement dust, salt water marine environments or to continual spraying of either salt or fresh water.

The Finish Warranty is VOID if (f) the practices specified by AAMA 609 & 610-02 – "Cleaning and Maintenance for Architecturally Finished Aluminum" ([www.aamanet.org](http://www.aamanet.org)) are not followed by Purchaser for IronRidge's aluminum based components; and (g) if the practices specified by ASTM A780 / A780M - 09 "Standard Practice for Repair of Damaged and Uncoated Areas of Hot-Dip Galvanized Coatings" are not followed by Purchaser for IronRidge's galvanized steel-based components.

The warranties above do not cover any parts or materials not manufactured by IronRidge, and exclude non-functionally-related defects, as defined solely by IronRidge. The warranties do not cover any defect that has not been reported to IronRidge in writing within 20 days after discovery of such defect.

In the event of breach of or non-compliance with the warranties set forth above, IronRidge's sole obligation and liability, and the sole and exclusive remedy for such breach or non-compliance, shall be correction of defects by repair, replacement, or credit, at IronRidge's sole discretion. Such repair, replacement or credit shall completely satisfy and discharge all of IronRidge's liability with respect to these warranties.

Refurbished Product may be used to repair or replace the defective components. Transportation, installation, labor, or any other costs associated with Product replacement are not covered by these warranties and are not reimbursable. These warranties additionally do not cover (h) normal wear, or damage resulting from misuse, overloading, abuse, improper installation (including failure to follow professional instruction and certification), negligence, or accident, or from force majeure acts including any natural disasters, war or criminal acts; and (i) Products that have been altered, modified or repaired without written authorization from IronRidge or its authorized representative; and (j) Products used in a manner or for a purpose other than that specified by IronRidge. A formal document proving the purchase and the purchase date of the Product is required with any warranty claim.

Except as set forth above, IronRidge sells the Products on an "AS IS" basis, which may not be free of errors or defects, and ALL EXPRESS OR IMPLIED REPRESENTATIONS AND WARRANTIES, INCLUDING ANY WARRANTIES OF MERCHANTABILITY, FITNESS FOR A PARTICULAR PURPOSE, QUALITY, WORKMANLIKE EFFORT, CORRESPONDENCE TO DESCRIPTION, DESIGN, TITLE OR NON-INFRINGEMENT, OR ARISING FROM COURSE OF DEALING, COURSE OF PERFORMANCE OR TRADE PRACTICE, ARE HEREBY DISCLAIMED.