

ROOF MOUNT

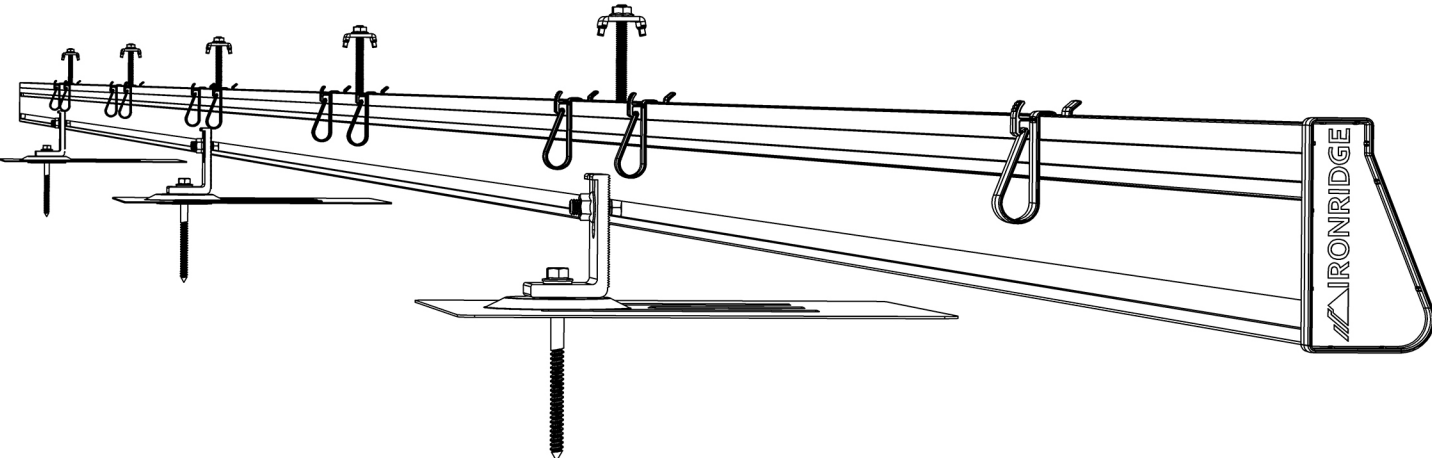

CONTENTS

DISCLAIMER	1
CHECKLIST	2
1. ATTACH BASE	3
2. PLACE RAILS	3
3. SECURE LUGS	4
4. CLAMP MODULES	4
ELECTRICAL DIAGRAM	5
EXPANSION JOINTS	5
ALTERNATIVE LUGS	6
END CAPS (OPTIONAL)	6
WIRE CLIPS (OPTIONAL)	6
GROUNDING STRAPS (OPTIONAL)	6
STANDOFFS (OPTIONAL)	7
TILT LEGS (OPTIONAL)	7
WARRANTY	8

DISCLAIMER

This manual describes the proper installation procedures and provides minimum standards required for product reliability and warranty. Thoroughly understanding this manual is imperative to proper installation; failure to follow the guidelines set forth can result in property damage, bodily injury, or even death.

IT IS THE INSTALLER'S RESPONSIBILITY TO:

- Comply with all applicable local or national building codes, including any that may supersede this manual.
- Ensure all products are appropriate for the installation, environment, and array under the site's loading conditions.
- Comply with all of roofing manufacturer's warranty terms, ensuring that any loose debris potentially obstructing installation procedures is removed from the installation area.
- Use only IronRidge parts or parts recommended by IronRidge; substituting parts may void any applicable warranty.
- Ensure safe installation of all electrical aspects of the array. All electrical installation and procedures should be conducted by a licensed and bonded electrician. All work must comply with national, state and local installation procedures, product and safety standards.
- Comply with roofing manufacturer's warranty terms including: using protective barriers between mounting and roofing and roof penetrations and removing all loose debris or gravel prior to installation.
- Review the [Engineering Design Guide](#) and [Certification Letters](#) to confirm any engineering specifications.
- Comply with all applicable fire codes including, but not limited to, keeping walkways clear and avoiding obstacles.
- Ensure provided information is accurate. Issues resulting from inaccurate information are the installers' responsibility.
- Confirm with the selected module manufacturer that the mounting is compatible with the selected module. Please consult module manufacturer's installation guidelines in order to verify mounting compatibility.

CHECKLIST

PRE-INSTALLATION

- Plan project with a Professional Engineer, reviewing the [Engineering Design Guide](#) and [Design Assistant](#).
- Schedule any necessary inspections and acquire any needed approval from the roofing manufacturer.
- Verify module compatibility with Roof Mount. For Integrated Grounding, ensure module is UL-listed.
- Verify that needed components have been obtained. Contact your local distributor for any additional parts.

TOOLS REQUIRED

- Cordless Drill (non-impact)
- Torque Wrench (0-240 in-lbs)
- 5/16" Socket (deep)
- 7/16" Socket (deep)
- 9/16" Socket (deep)
- 1/8" Allen Wrench
- 3/8" Socket (for Tilt Legs)

TORQUE VALUES

Reduce torque values by 15% when lubricated.

- FlashFoot Lag Bolts (5/16"-9): Fully seat
- L-Feet Nuts (3/8"-16): 236 in-lbs (dry)
- Internal Splice Screws (1/4"-14): 84 in-lbs (dry)
- Grounding Lug Nuts (1/4"-20): 84 in-lbs (dry)
- Grounding Lug Set Screws (1/4"-28): 15 in-lbs (dry)
- End Clamp Nuts (1/4"-20): 65 in-lbs (dry)
- Mid Clamp Nuts (1/4"-20): 84 in-lbs (dry)
- Expansion Joint Nuts (1/4"-20): 84 in-lbs (dry)
- Tilt Leg Nuts (3/8"-16): 180 in-lbs (dry)
- Flush Standoff (5/16"-18): 139 in-lbs (dry)

PRIMARY COMPONENTS

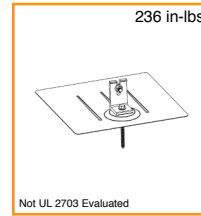

FlashFoot™
Aluminum

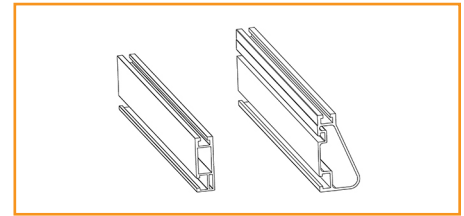

IronRidge Rail
Aluminum

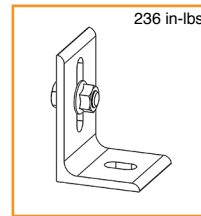

L-Foot
Aluminum

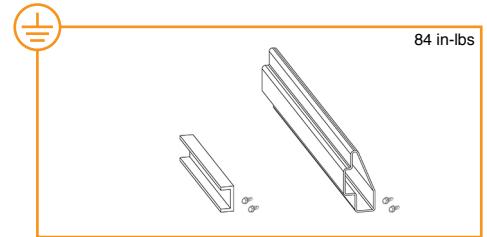

Internal Splice
Aluminum

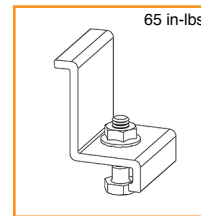

End Clamp
Aluminum

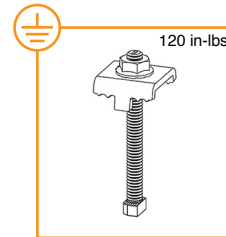

Mid Clamp
Stainless Steel

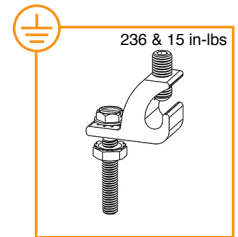

Grounding Lug
Tinned Cu & SS

SECONDARY COMPONENTS



End Cap
Polycarbonate



Wire Clip
Polycarbonate

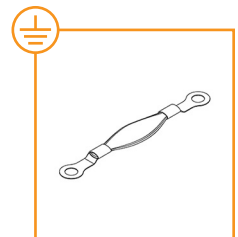

Grounding Strap
Tinned Copper

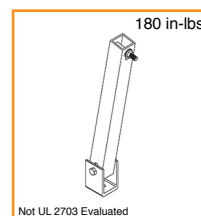

Tilt Leg
Aluminum

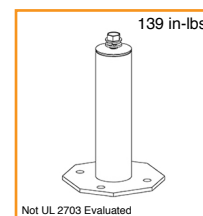

Standoff
Aluminum & SS

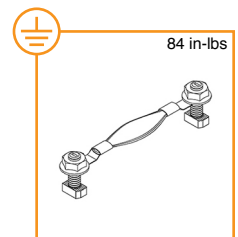

Expansion Joint
Tinned Cu & SS

1. ATTACH BASE

For composition shingle roofs, use FlashFoot. For other roofs, mount L-Feet on suitable third-party attachments.

FLASHFOOT™

Locate and mark locations on roof. Drill 1/4" pilot holes and backfill with approved sealant. Slide flashing between 1st and 2nd course of shingles. Line up pilot hole and fully seat lag bolt through washer, L-Foot, and flashing.

- ☑ Spacing varies with load conditions. Consult engineering specs.
- ☑ Refer to [Page 7](#) for installing Standoffs or Tilt Legs.
- ☑ If using FlashFoot with Tilt Legs, replace L-Foot with U-Foot and add [EcoFasten CP-SQ-Slotted Bracket](#) with extra flat washer.

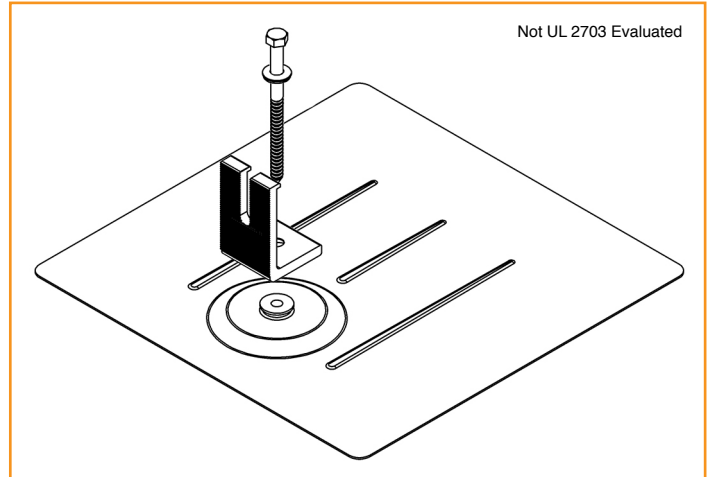

2. PLACE RAILS

A. PREPARE HARDWARE

On the ground, slide 3/8"-16 hardware into side-facing rail slot. Space out bolts to match L-Feet spacing.

- ☑ Tape ends of rail, to keep bolts from sliding out while moving.
- ▶ If using Mid Clamps with hex bolts, slide provided 1/4"-20 bolts into top slot of rails at this time. Space bolts for panel spacing.

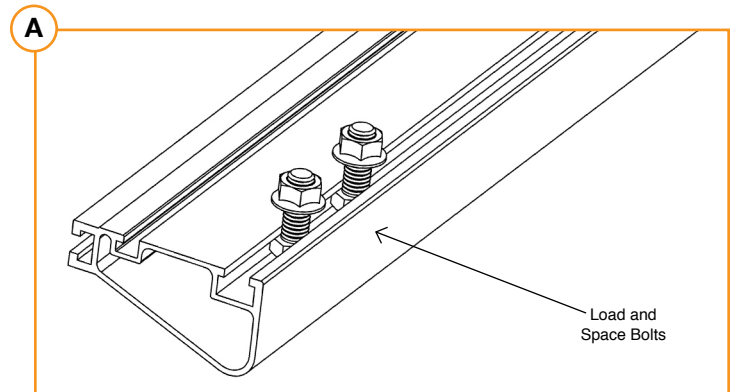

B. SPLICE CONNECTIONS ⊕

Insert Internal Splice into first rail and secure with provided screw. Slide second rail over Internal Splice and secure with provided screw. Torque screws to 84 in-lbs. Repeat splices for all rail connections.

- ☑ [Grounding Straps](#) should be installed at this time. For rows exceeding 100 feet of rail, an [Expansion Joint](#) is needed for thermal expansion. See [Pages 5-6](#) for more info.

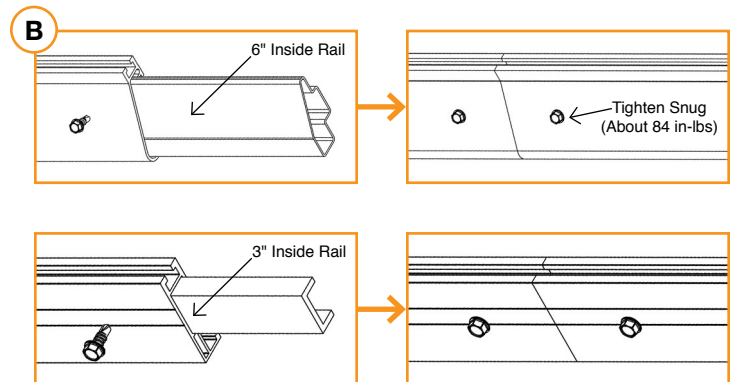

C. FASTEN L-FEET

Attach rails to L-Feet using preloaded hardware. Position rails at desired height and level. Torque to 236 in-lbs (dry).

- ☑ To level rails, adjust L-Foot attachments to same height from roof.

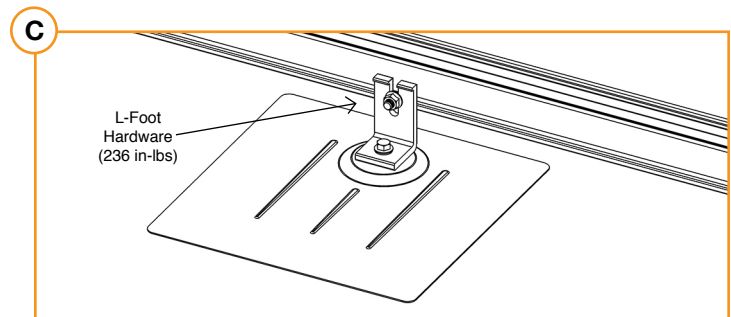

3. SECURE LUGS

IRONRIDGE LUGS ⊕

Using a 13/64" or #7 drill bit, drill a hole through side of rail at least 1/2" from the end and centered. Attach lug and secure 10AWG (minimum) copper grounding wire. Torque hex bolt to 32 in-lbs. Torque set screw to 20 in-lbs for 10AWG, 25 in-lbs for 8AWG, or 35 in-lbs for 4-6AWG.

- ☑ For WEEB Lugs, review [Wiley WEEB Installation Instructions](#).
- ☑ Grounding hardware is only needed on one rail per row of modules. Grounding Lugs and Straps should be on same rail.

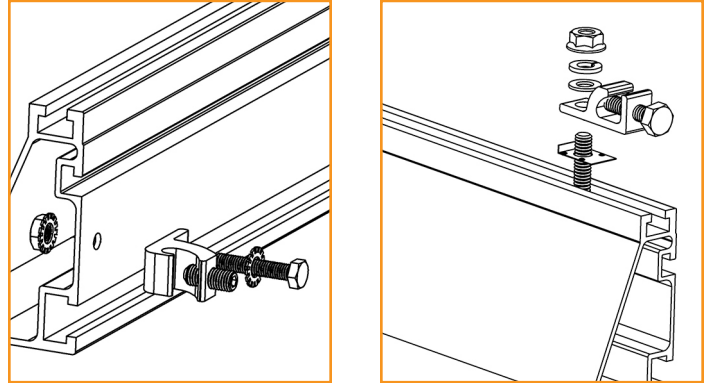

4. CLAMP MODULES

A. END CLAMPS

Place first module in position on rails, a minimum of 1.5" from rail ends. Secure End Clamp on rail, ensuring it is hooked over top of module. Torque to 65 in-lbs. Repeat with End Clamp on other rail.

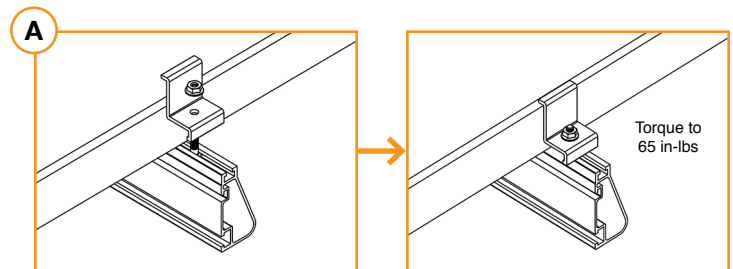

B. GROUNDING MID CLAMPS ⊕

Assemble Grounding Mid Clamp and position next to first module. Slide second module into position under clamp and secure. Ensure the clamp teeth are in contact with both of the module frames and the bolt is properly aligned in slot. Torque to 84 in-lbs (dry). Repeat the procedure to secure each following module.

- ☑ If needed, present [Integrated Grounding Certification Letter](#) to inspector.
- ▶ If using Standard Mid Clamps with ETL-listed WEEB Clips, refer to [Wiley WEEB Installation Instructions](#). Torque to 120 in-lbs (dry).

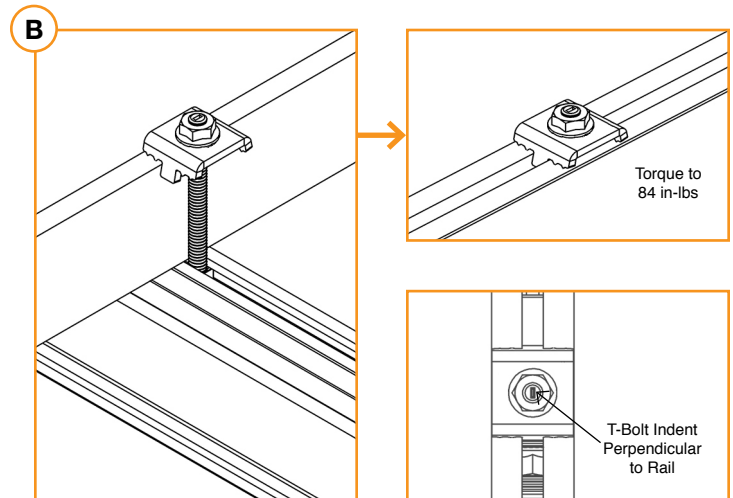

C. END CLAMPS

Place last module in position on rails, a minimum of 1.5" from rail ends. Secure End Clamp on rail, ensuring it is hooked over top of module. Torque to 65 in-lbs. Repeat with End Clamp on other rail.

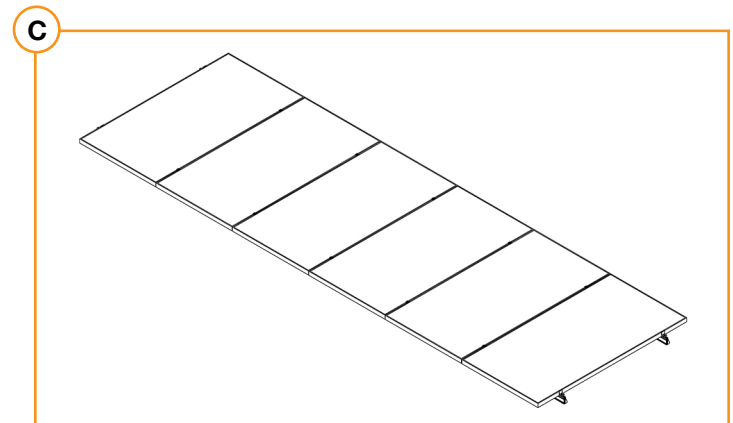

D. REPEAT STEPS

Install remaining module rows.

ELECTRICAL DIAGRAM

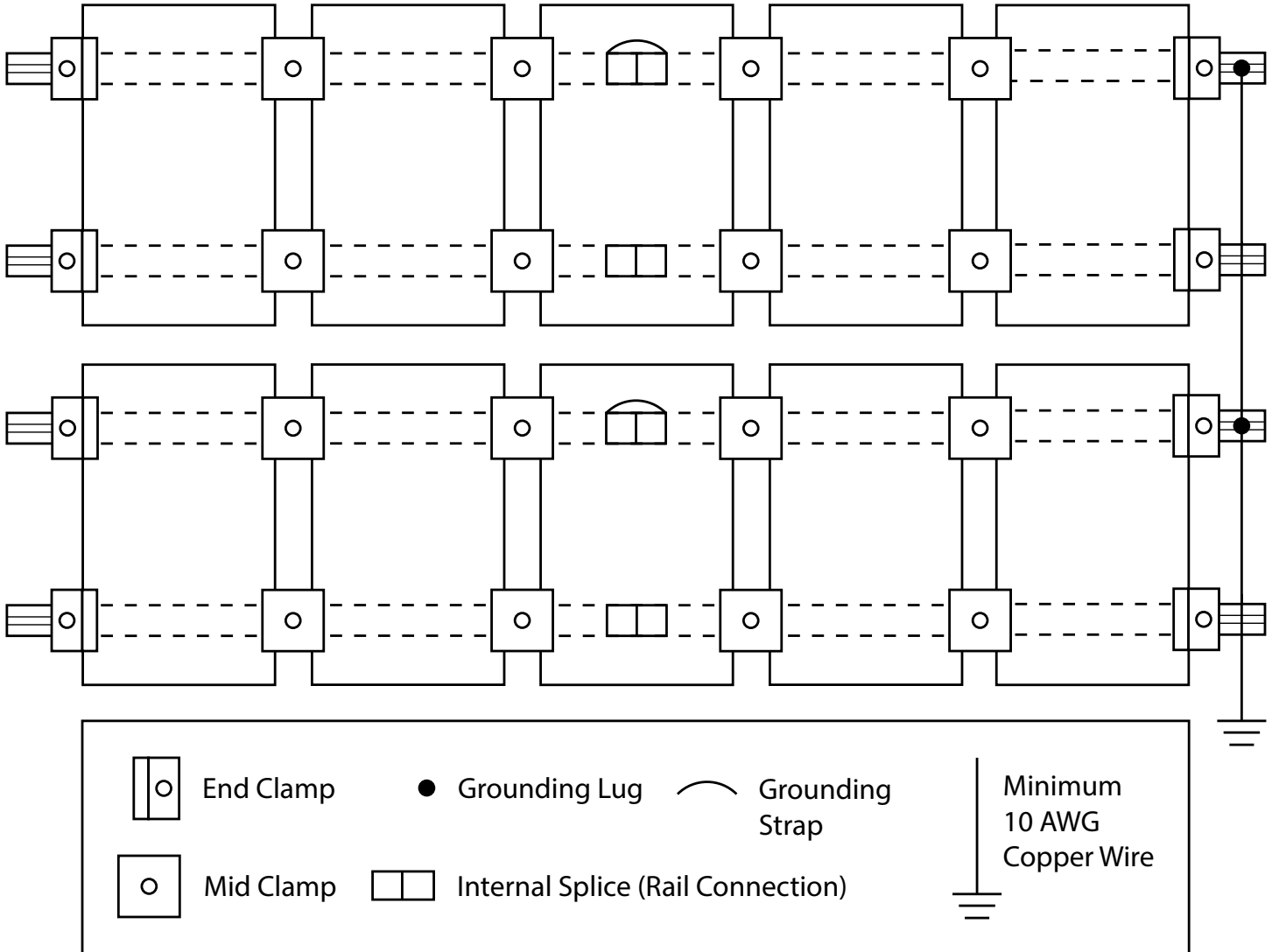

EXPANSION JOINTS

For rows exceeding 100 feet of rail, a Grounding Strap Expansion Joint is required for thermal expansion.

Insert Internal Splice into first rail and secure with screw. Assemble and secure Expansion Joint an inch from rail end. Slide second rail over splice and attach other end of Expansion Joint with hardware, leaving splice secured only on one side. Torque screws and nuts to 84 in-lbs.

- ☑ Do not splice middle 1/3 of spans nor end spans of rows.
- ☑ Modules should not span over Expansion Joints and should have End Clamps on each side of joint.

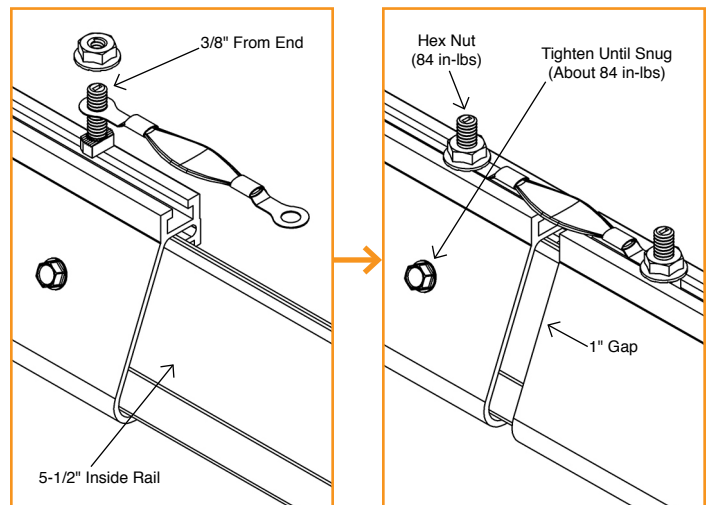

GROUNDING STRAPS

Insert Internal Splice into first rail and secure with strap, star washer, and screw. Slide second rail over Internal Splice and secure with strap, star washer, and screw. Torque screws to 84 in-lbs. Repeat for all splices.

☑ Grounding hardware is only needed on same rail as lug.

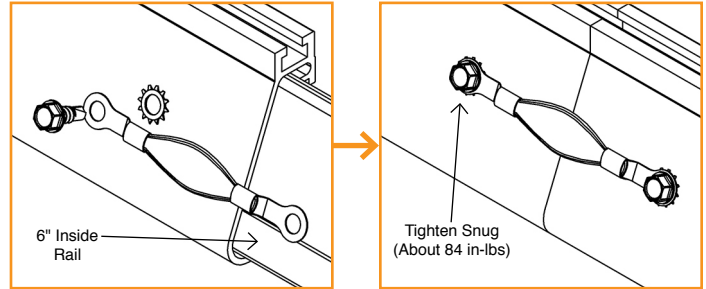

END CAPS (OPTIONAL)

End Caps add a completed look and keep debris and pests from collecting inside rails.

Firmly press End Cap onto rail end.

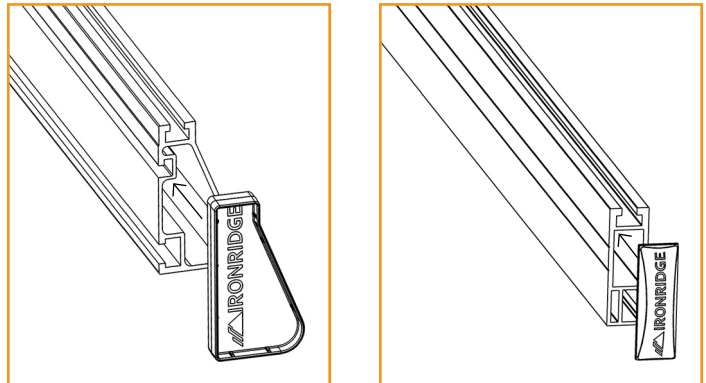

WIRE CLIPS (OPTIONAL)

Wire Clips offer a simple wire management solution.

Firmly press Wire Clip into top rail slot. Open clip and insert electrical wire accordingly. Close clip once complete.

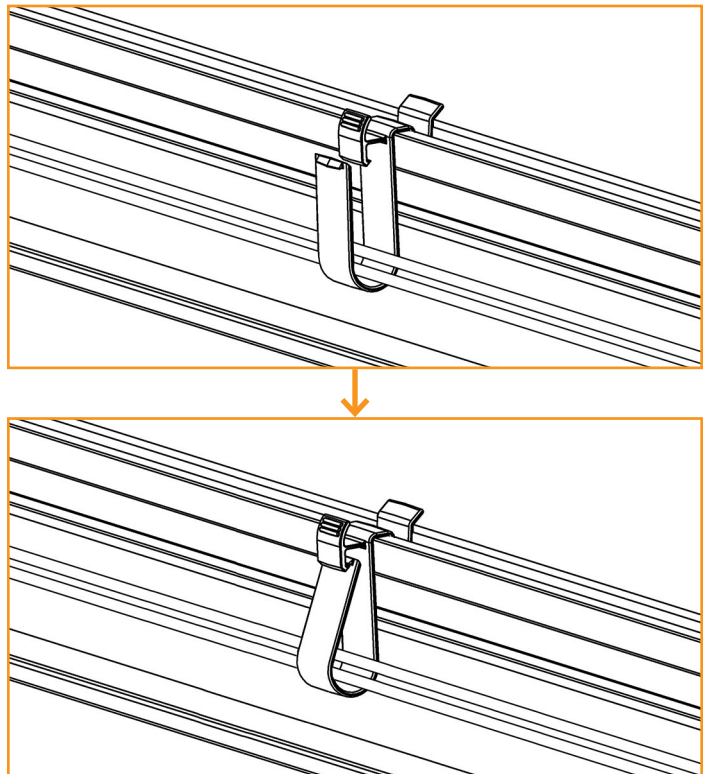

STANDOFFS (OPTIONAL)

FLUSH STANDOFFS

Attach Standoffs to roof locations with lag bolts (not included). Place flashing over Standoff. Attach L-Foot on top of Standoff washer with hardware. Torque to 139 in-lbs.

- ☑ Only attach to Tilt Legs if assembly is tilted 10 degrees or less.

TILT STANDOFFS

Refer to [QuickMount PV QBase Low Slope Mount Manual](#).

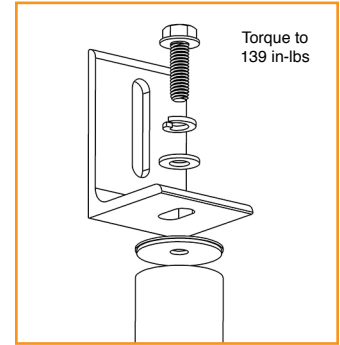
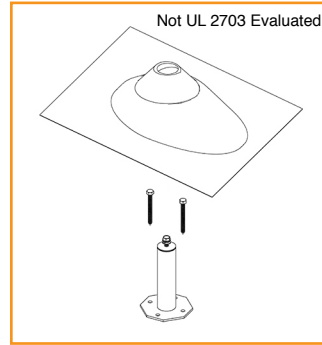

TILT LEGS (OPTIONAL)

A. MOUNT U-FEET

Mount all U-Feet on top of roof attachments and torque to required specifications.

- ☑ Determine the maximum distance between U-Feet, according to engineering specifications.

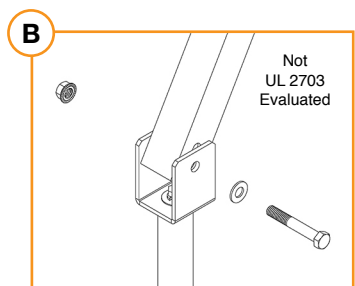
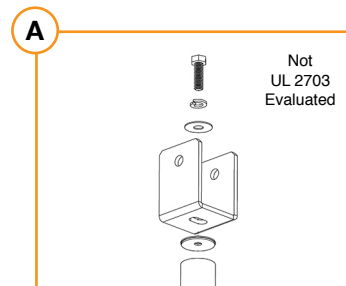

B. PLACE TILT LEGS

Place Tilt Legs into U-Feet, aligning slots of legs with U-Footer holes. Insert 3/8"-16 bolt with washer into hole and attach nut. Finger tighten, to allow pivoting.

- ☑ For Adjustable Tilt Legs, join inner and outer legs with hardware.

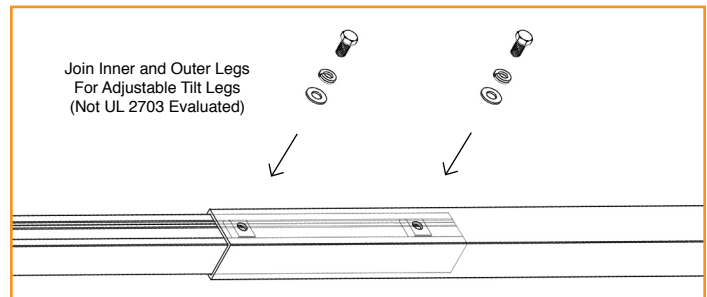

C. ATTACH RAILS

Slide bolts into 3/8" rail slot. Lay rail in place, next to legs, and line up bolts with rail to attach. Place nut and finger tighten, to allow alignment.

- ☑ For Adjustable Tilt Legs, attach pivot bracket to north rail in each position where legs will connect. Adjust leg to desired length.

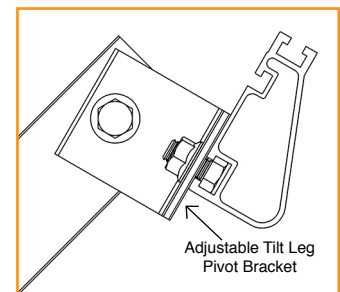
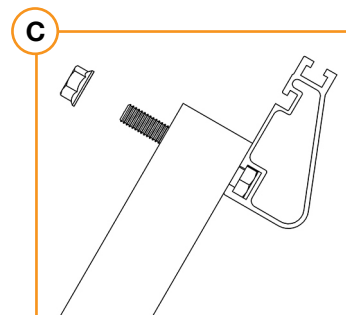

D. TILT ASSEMBLY

Make sure assembly is aligned and square. Tilt assembly to desired angle. Tighten all bolts to 180 in-lbs.

- ☑ Check with module manufacturer for rail placement specifics. Place rails from module's edge, up to 20% of the module's length.

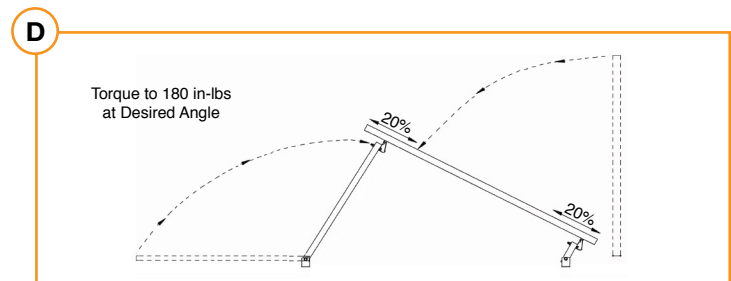

Effective for IronRidge, Inc. (“IronRidge”) mounting structure components (“Products”) manufactured after April 1st, 2012, IronRidge provides the following warranties, for Products installed properly and used for the purpose for which the Products are designed:

- finishes shall be free of visible defects, peeling, or cracking, under normal atmospheric conditions, for a period of three (3) years from the earlier of (i) the date of complete installation of the Product or (ii) thirty days after the original purchaser’s date of purchase of the Product (“Finish Warranty”);
- components shall be free of structurally-related defects in materials for a period of ten (10) years from the earlier of (i) the date of complete installation of the Product or (ii) thirty days after the original purchaser’s date of purchase of the Product;
- components shall be free of functionally-related manufacturing defects for a period of twenty (20) years from date of manufacture.

The Finish Warranty does not apply to: (a) surface oxidation of the galvanized steel components or any foreign residue deposited on Product finish; and (b) Products installed in corrosive atmospheric conditions, as defined solely by IronRidge; corrosive atmospheric conditions include, but are not limited to, conditions where Product is exposed to corrosive chemicals, fumes, cement dust, salt water marine environments or to continual spraying of either salt or fresh water. The Finish Warranty is VOID if (c) the practices specified by AAMA 609 & 610-02 – “Cleaning and Maintenance for Architecturally Finished Aluminum” (www.aamanet.org) are not followed by Purchaser for IronRidge’s aluminum based components; and (d) if the practices specified by ASTM A780 / A780M - 09 “Standard Practice for Repair of Damaged and Uncoated Areas of HotDip Galvanized Coatings” are not followed by Purchaser for IronRidge’s galvanized steel-based components.

The warranties above do not cover any parts or materials not manufactured by IronRidge, and exclude nonfunctionally-related defects, as defined solely by IronRidge. The warranties do not cover any defect that has not been reported to IronRidge in writing within twenty (20) days after discovery of such defect.

In the event of breach of or non-compliance with the warranties set forth above, IronRidge’s sole obligation and liability, and the sole and exclusive remedy for such breach or non-compliance, shall be correction of defects by repair, replacement, or credit, at IronRidge’s sole discretion. Such repair, replacement or credit shall completely satisfy and discharge all of IronRidge’s liability with respect to these warranties.

Refurbished Product may be used to repair or replace the defective components. Transportation, installation, labor, or any other costs associated with Product replacement are not covered by these warranties and are not reimbursable. These warranties additionally do not cover (a) normal wear, or damage resulting from misuse, overloading, abuse, improper installation (including failure to follow professional instruction and certification), negligence, or accident, or from force major acts including any natural disasters, war or criminal acts; and (b) Products that have been altered, modified or repaired without written authorization from IronRidge or its authorized representative; and (c) Products used in a manner or for a purpose other than that specified by IronRidge. A formal document proving the purchase and the purchase date of the Product is required with any warranty claim.

Except as set forth above, IronRidge sells the Products on an “AS IS” basis, which may not be free of errors or defects, and ALL EXPRESS OR IMPLIED REPRESENTATIONS AND WARRANTIES, INCLUDING ANY WARRANTIES OF MERCHANTABILITY, FITNESS FOR A PARTICULAR PURPOSE, QUALITY, WORKMANLIKE EFFORT, CORRESPONDENCE TO DESCRIPTION, DESIGN, TITLE OR NON-INFRINGEMENT, OR ARISING FROM COURSE OF DEALING, COURSE OF PERFORMANCE OR TRADE PRACTICE, ARE HEREBY DISCLAIMED.