



M250 (M250-60-2LL) Safety

Important Safety Information

This document contains important instructions to use during installation of the Enphase M250 Microinverter™. To reduce the risk of electrical shock, and to ensure the safe installation and operation of the Enphase Microinverter, follow these instructions. The following safety symbols and information indicate dangerous conditions and important safety instructions.

Product Labels

	WARNING: Hot surface.
	DANGER: Risk of electrical shock.
	Refer to product instructions.















Safety and Advisory Symbols





	DANGER! This indicates a hazardous situation, which if not avoided, will result in death or serious injury.
	WARNING! This indicates a situation where failure to follow instructions may be a safety hazard or cause equipment malfunction. Use extreme caution and follow instructions carefully.
	WARNING! This indicates a situation where failure to follow instructions may result in burn injury.
	NOTE: This indicates information particularly important for optimal system operation. Follow instructions closely.

Safety Instructions

	DANGER: Before installing or using the Enphase Microinverter, read all instructions and cautionary markings in the technical description, on the Enphase Microinverter System, and on the photovoltaic (PV) equipment.
	DANGER: Do not use Enphase equipment in a manner not specified by the manufacturer. Doing so may cause death or injury to persons, or damage to equipment.
	DANGER: Risk of Electrical Shock. Be aware that installation of this equipment includes risk of electric shock. Do not install the AC junction box without first removing AC power from the Enphase System.
	DANGER: The Engage Cable terminator cap must not be installed while power is connected.
	DANGER: Electric shock hazard. The DC conductors of this photovoltaic system are ungrounded and may be energized.
	WARNING: Always de-energize the AC branch circuit before servicing. Never disconnect the DC connectors under load. Disconnect DC connections first, then disconnect AC connections.
	WARNING: The body of the Enphase Microinverter is the heat sink. Under normal operating conditions, the temperature is 15°C above ambient, but under extreme conditions the microinverter can reach a temperature of 80°C. To reduce risk of burns, use caution when working with microinverters.
	WARNING: The M250 may be paired only with a 60-cell PV module. The PV module DC conductors must be labeled "PV Wire" or "PV Cable" to be compliant with NEC 690.35(D) for Ungrounded PV Power Systems.

	WARNING: If the AC cable on the microinverter is damaged, do not install the unit.
	WARNING: You must match the DC operating voltage range of the PV module with the allowable input voltage range of the Enphase Microinverter: 16-48V.
	WARNING: The maximum open circuit voltage of the PV module must not exceed the specified maximum input voltage of the Enphase Microinverter: 48V DC.
	WARNING: The M250 has field-adjustable voltage and frequency trip points that you may need to set, depending upon local requirements. Only an authorized installer with the permission and following requirements of the local electrical authorities should make adjustments.
	WARNING: Only use electrical system components approved for wet locations.
	WARNING: Only qualified personnel should troubleshoot, install, or replace Enphase Microinverters or the Engage Cable and Accessories.
	WARNING: Make sure protective sealing caps have been installed on all unused AC connectors. Unused AC connectors are live when the system is energized by the grid. Sealing caps may not be reused.
	WARNING: Ensure that all AC and DC wiring is correct and that none of the AC or DC wires are pinched or damaged. Ensure that all AC junction boxes are properly closed.

	WARNING: The microinverter must be installed under the module, out of rain and sun. Do not mount the microinverter in a position that allows long-term exposure to direct sunlight or in a vertical orientation that allows water to collect in the DC connector recess. Do not install the microinverter black side up or vertically, with the DC connectors facing up.
	WARNING: When installing the Engage Cable, secure any loose cable to minimize tripping hazard.
	WARNING: Do not leave AC connectors on the Engage Cable uncovered for an extended period. If you do not plan to replace the microinverter immediately, you must cover any unused connector with a sealing cap. Sealing caps may not be reused.
	WARNING: Do not exceed the maximum number of microinverters in an AC branch circuit as listed in the manual. You must protect each microinverter AC branch circuit with a 20A maximum breaker.
	WARNING: Do not connect Enphase Microinverters to the grid or energize the AC circuit(s) until you have completed all of the installation procedures and have received prior approval from the electrical utility company.
	WARNING: Do not attempt to repair the Enphase Microinverter; it contains no user-serviceable parts. If it fails, contact Enphase customer service to obtain an RMA (return merchandise authorization) number and start the replacement process. Tampering with or opening the Enphase Microinverter will void the warranty.
	WARNING: Be aware that only qualified personnel must connect the Enphase Microinverter to the utility grid.
	WARNING: The Engage Cable terminator cap is intended for one-time use only. If you open the terminator after initial installation, the latching mechanism is destroyed and the terminator cap cannot be used again. If the latching mechanism is defective, the terminator must not be used. The latching mechanism must not be circumvented or manipulated.
	WARNING: When stripping the sheath from the Engage Cable, make sure that the conductors are not damaged. If the exposed wires are damaged, the system may not function properly.
	WARNING: Perform all electrical installations in accordance with all applicable local electrical codes and the National Electrical Code (NEC), ANSI/NFPA 70.
	NOTE: Check the labeling on the Engage Cable drop connectors to be sure that the cable matches the electrical utility service at the site. Use 208 VAC (208 VAC three-phase) Engage Cable at sites with three-phase 208 VAC service, or use 240 VAC Engage Cable at sites with 240 VAC single-phase service.
	NOTE: There are two release-holes in the drop connector on the cable. These are not for mounting but are used to disconnect the connector. Keep these release holes clear and accessible.
	NOTE: Protection against lightning and resulting voltage surge must be in accordance with local standards.
	NOTE: Many PV modules have a central stiffening brace. In these cases, do not position the connector and microinverter at the exact center of the PV module. Instead, position the drop connectors so that the connectors do not conflict with the braces.

	NOTE: If you need to remove a sealing cap, you must use the Enphase disconnect tool or a #3 Phillips screwdriver. Sealing caps may not be reused.
	NOTE: The M250 works with 240 VAC single-phase utility service or with 208 VAC three-phase utility service
	NOTE: When installing the Engage Cable and accessories, adhere to the following: <ul style="list-style-type: none"> • Do not expose the connection to directed, pressurized liquid (water jets, etc.). • Do not expose the connection to continuous immersion. • Do not expose the AC connector to continuous tension (e.g., tension due to pulling or bending the cable near the connection). • Use only the connectors and cables provided. • Do not allow contamination or debris in the connectors. • Use the cable and connectors only when all parts are present and intact. • Fit the connections using only the prescribed tools. • Use the terminator to seal the conductor end of the Engage Cable; no other method is allowed.
	NOTE: Do not use the shipping cap to cover unused connectors. The shipping cap does not provide an adequate environmental seal. Enphase sealing caps are required for the system to be UL compliant and to protect against moisture ingress.
	NOTE: Completely install all microinverters and all system AC connections prior to installing the PV modules.



Installation Map

You can build the system map manually, or you can use the ArrayGun feature from the Enphase Installer Toolkit to easily build and configure a system. For more information, refer to <http://enphase.com/products/arraygun>.

To manually build the Installation Map:

- Peel the removable serial number label from each microinverter and affix it to the respective location on the installation map.
- Peel the label from the Envoy and affix it to the installation map.
- Log in to Enlighten.
- Scan the installation map and upload it to the System Activation form online.
- Use Array Builder to create the virtual array using the installation map as your reference.
- To see the Array Builder demo, refer to <http://enphase.com/support/videos>.

To Sheet: _____

Panel Group: Azimuth: Tilt: sheet ____ of ____	Customer information:			Installer information:			N S E W (circle one)
	1	2	3	4	5	6	7

A								
B								
C								
D								
E								
F								
G								
H								
J								
K								
L								
M								

To Sheet: _____

To Sheet: _____

Scan completed map and upload it to Enphase. Click "Add New System" at www.enlighten.enphaseenergy.com. Use this map to build the virtual array in Enlighten's Array Builder.

Envoy Serial Label



INSTALLATION MAP

DOCUMENT NUMBER:
140-00003
REVISION:
04

To Sheet: _____

Installing the M250 Microinverter (M250-60-2LL)

NOTE: The M250 meets the requirements of NEC 690.35. Because the DC circuit is isolated and insulated from ground, the M250 does not require that you install a GEC between microinverters. To support this feature, the PV module must be equipped with DC cables labeled “PV Wire” or “PV Cable.”

Read the included safety information and follow all warnings and instructions in the *M250 Installation and Operation Manual* at <http://www.enphase.com/support> before installing the Enphase M250™ Microinverter.

1

Connect the Envoy® Communications Gateway™

- Connect the Envoy to power and Internet according to the *Envoy Quick Install Guide*.
- Look for the + Web indication on the LCD screen.
- Leave the Envoy running while you install the microinverters so that any required Envoy software upgrade completes.

Warning: Do not remove power from the Envoy if the LCD displays: “Upgrading. . . Do Not Unplug.”

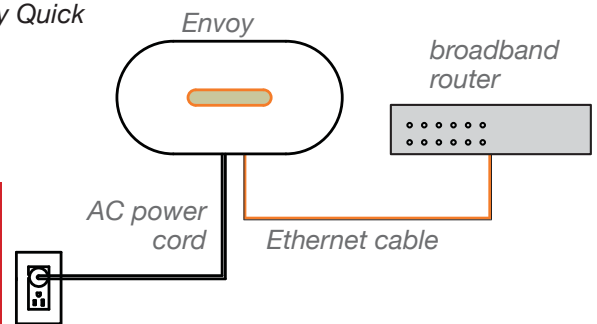

2

Position the Enphase Engage™ Cable

- Lay out the cabling along the installed racking for the AC branch circuit.
- Install an appropriately rated, off-the-shelf junction box at a suitable location on the racking.

See notes in **Step Details** on back.

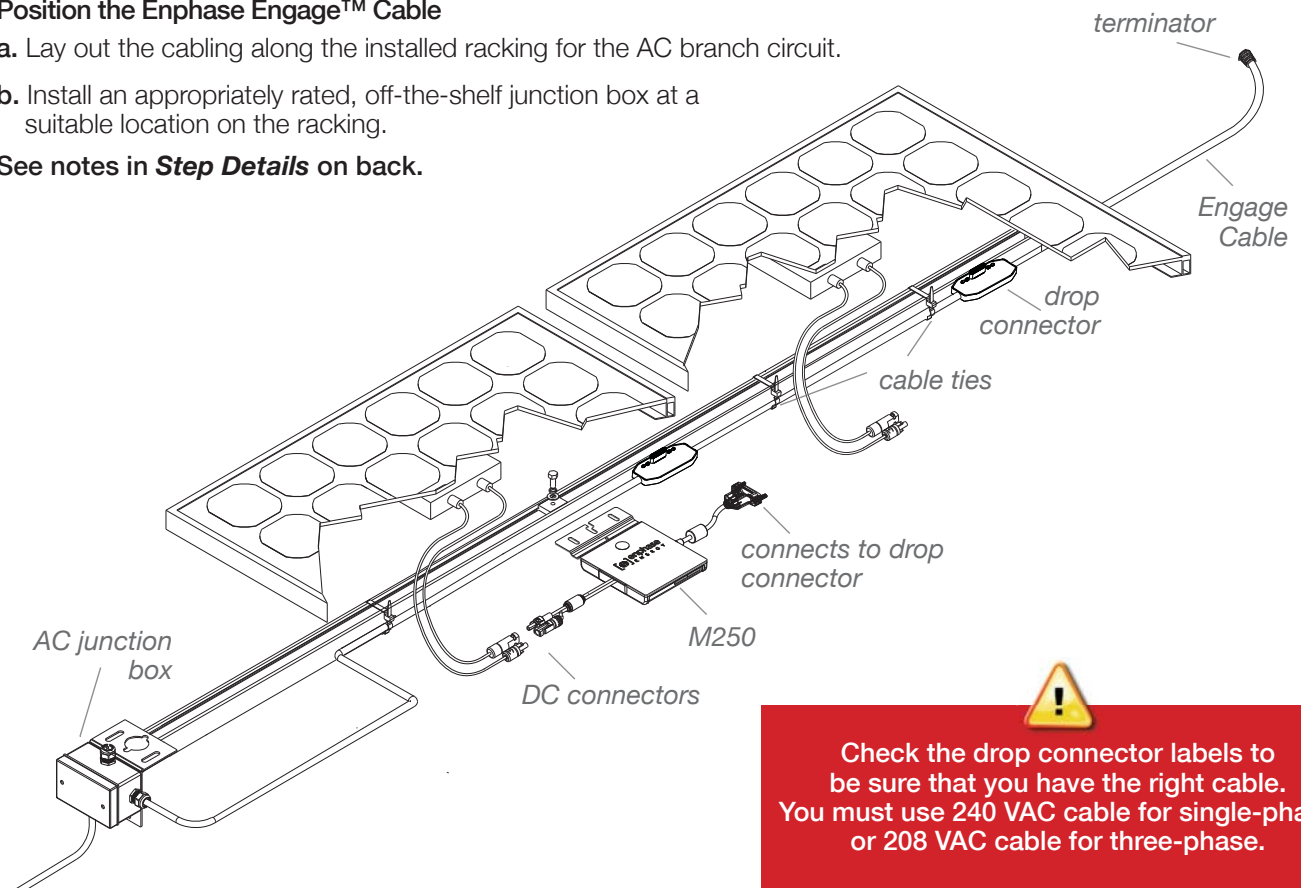

Check the drop connector labels to be sure that you have the right cable. You must use 240 VAC cable for single-phase or 208 VAC cable for three-phase.

M250 Microinverter Quick Install Guide

3 Attach the Microinverters to the PV Racking

- a. Mark the approximate centers of each PV module on the PV racking. **See notes in Step Details on back.**

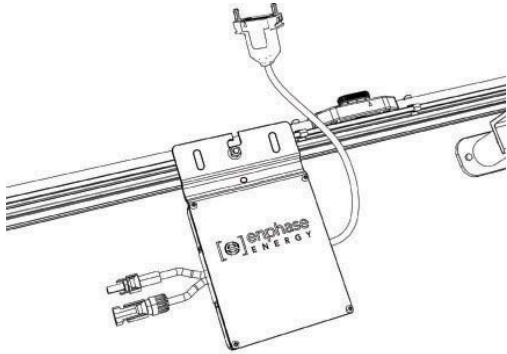

- b. Mount the microinverter under the PV module, away from rain and sun. Do not mount the microinverter in a position that allows long-term exposure to direct sunlight or in a vertical orientation that allows water to collect in the DC connector recess.
- c. Torque the microinverter fasteners as follows. Do not over torque:
- 5 N m (45-50 in-lbs) for 6 mm (1/4") hardware
 - 9 N m (80-85 in-lbs) for 8 mm (5/16") hardware

4 Dress the Cable

- a. Attach the cabling to the rack using cable clips or tie wraps.

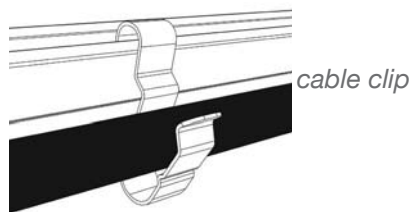

Keep the drop connector release holes clear and accessible.

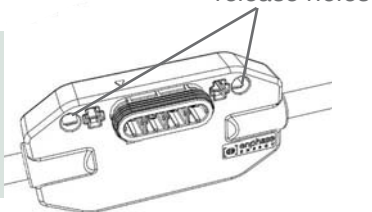

- b. Dress any excess cabling in loops so that it does not contact the roof.

NOTE: The M250 meets the requirements of NEC 690.35. Because the DC circuit is isolated and insulated from ground, the M250 does not require a GEC. For further information, refer to: <http://enphase.com/global/files/M250-and-Ungrounded-Array.pdf>.

5 Connect the Microinverters

- a. Remove and discard the temporary shipping cap from the cable connector and connect the microinverter. Listen for two clicks as the connectors engage.

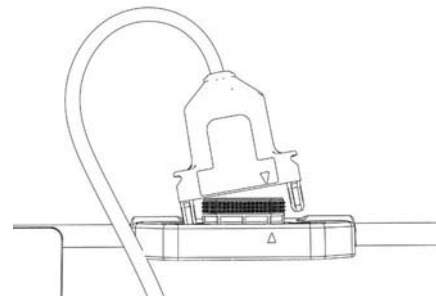

- b. Cover any unused connectors with sealing caps. Listen for two clicks as the connectors engage. **See notes in Step Details on back.**

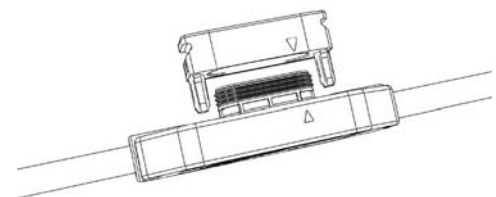

Do not use shipping caps to cover unused connectors. The shipping cap does not provide an adequate environmental seal.

6**Terminate the Unused End of the Cable**

- a. Remove 60 mm (2.5") of the cable sheath from the conductors.

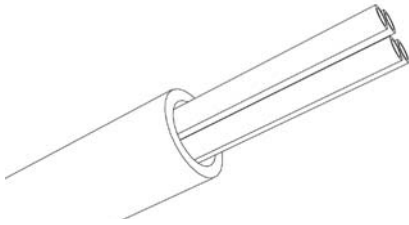

- b. Check that all terminator parts are present.

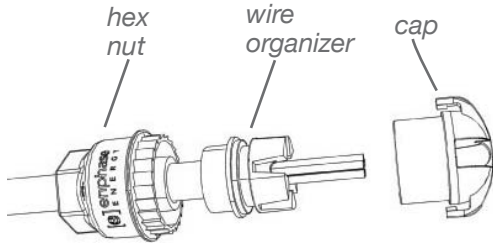

- c. Slide the hex nut onto the cable.
 d. Insert the cable end all the way into the wire organizer (up to the stop).
 e. Attach the cap.

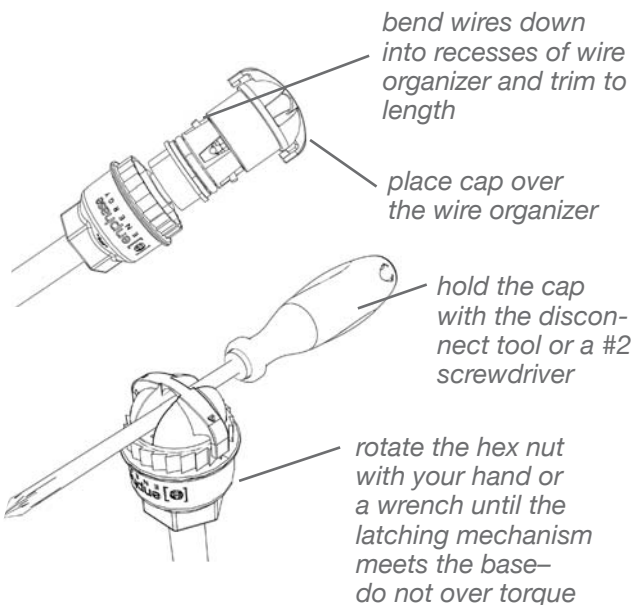

- f. Attach the terminated cable end to the PV racking with a cable clip or tie wrap.



Never unscrew the hex nut. This action can twist and damage the cable.

7**Connect the Cable to the AC Junction Box**

Connect the cable into the AC branch circuit junction box. **See notes in Step Details on back.**

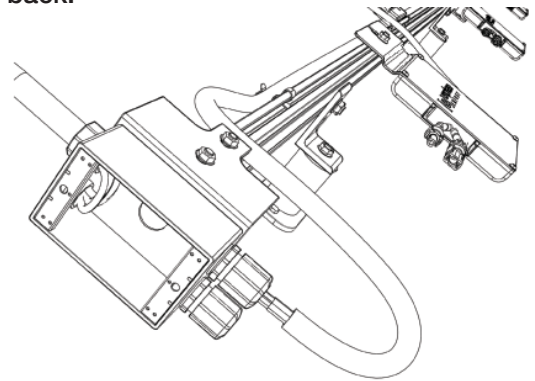
**8****Complete the Installation Map**

Build the map manually, or use the Array Gun tool to map the system. For more information, go to <http://enphase.com/products/arraygun>.

To manually build the map, peel the removable serial number label from each microinverter and affix it to the respective location on the map included with this guide.

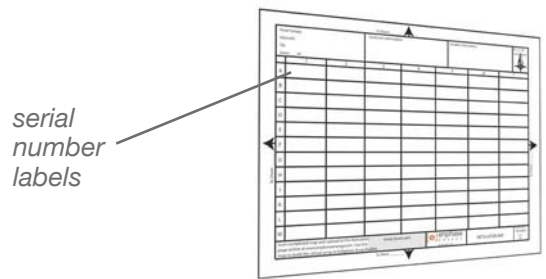
**9****Connect the PV Modules**

- a. Mount the 60-cell PV modules above the micro-inverters.
 b. Connect the DC leads of each 60-cell PV module to the DC input connectors of their corresponding microinverter.

The status LED on the underside of each M250 lights green six seconds after DC power is applied. It remains lit solid for two minutes, followed by six green blinks. After that, red blinks indicate that no grid is present. This is because the system is not yet energized.

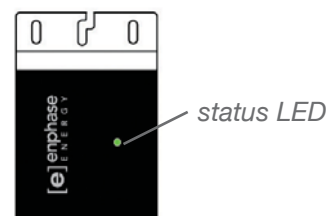

10

Energize the System

- a. If applicable, turn ON the AC disconnect or circuit breaker for the branch circuit.
- b. Turn ON the main utility-grid AC circuit breaker. Your system will start producing power **after a five-minute wait time.**

11

Use the Envoy to Complete System Setup

Refer to the to the *Envoy Quick Install Guide* for details on the following steps:

- a. An automatic device scan runs for eight hours after the Envoy is installed. If this scan has expired, start a new scan:
 - Press and hold the Envoy menu button (on the right side of the Envoy).
 - Release the menu button when the LCD screen displays **Enable Device Scan.**
- b. Check that the LCD shows a complete device count after about 30 minutes.
- c. Use the Envoy menu button to select **Enable Communication Check.** Ensure at least three level bars show on the LCD.
- d. When all devices are detected, stop the scan. To do this, use the Envoy menu button to select **Disable Device Scan.**

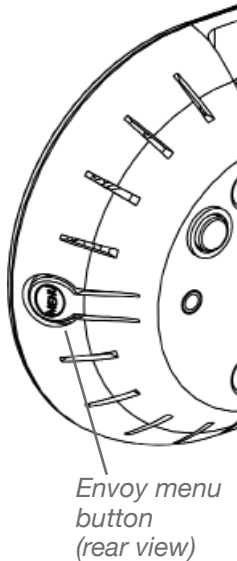

Envoy menu button (rear view)

Step Details

2

NOTE: Verify that AC voltage at the site is within range:

240 Volt AC Single-Phase		208 Volt AC Three-Phase	
L1 to L2	211 to 264 VAC	L1 to L2 to L3	183 to 229 VAC
L1, L2, to N	106 to 132 VAC	L1, L2, L3 to N	106 to 132 VAC

WARNING: Only use electrical system components approved for wet locations.

WARNING: Do not exceed the maximum number of microinverters in an AC branch circuit as listed in the table below. Each branch circuit must be protected by a dedicated circuit breaker of 20 A or less.

Service type	Max M250s per branch
240 VAC single-phase	16
208 VAC three-phase	24

WARNING: Size the AC wire gauge to account for voltage drop for both the branch circuit and all upstream conductors leading back to the PCC. See **Circuit Calculations for M250** at <http://www.enphase.com/support>.

3

DANGER: ELECTRIC SHOCK HAZARD. THE DC CONDUCTORS OF THIS PHOTOVOLTAIC SYSTEM ARE UNGROUNDED AND MAY BE ENERGIZED.

WARNING: Allow a minimum of 1.9 cm (0.75") between the roof and the microinverter. Also allow 1.3 cm (0.50") between the back of the PV module and the top of the microinverter.

NOTE: Torque the microinverter fasteners to the values shown. Do not over torque:

- 1/4" mounting hardware – 5 N m (45-50 in-lbs)
- 5/16" mounting hardware – 9 N m (80-85 in-lbs)

Using a power screwdriver is not recommended due to the risk of thread galling.

NOTE: The AC output neutral is not bonded to ground inside the microinverter.

5

WARNING: Install sealing caps on all unused AC connectors as these become live when the system is energized by the utility. The IP67-rated sealing caps are required for protection against moisture ingress.

NOTE: To remove a sealing cap, you must use the Enphase disconnect tool or a #3 Phillips screwdriver.

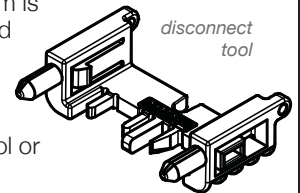

7

NOTE: The Engage Cable uses the following wiring scheme.

240 Volt AC Single-Phase Wires	208 Volt AC Three-Phase Wires
Black – L1	Black – L1
Red – L2	Red – L2
White – Neutral	Blue – L3
Green – Ground	White – Neutral
	Green – Ground

NOTE: The green wire acts as equipment ground (EGC).

Enphase Energy, Inc.
1420 N. McDowell Blvd.
Petaluma, CA 94954
USA

info@enphaseenergy.com
<http://www.enphase.com>

