

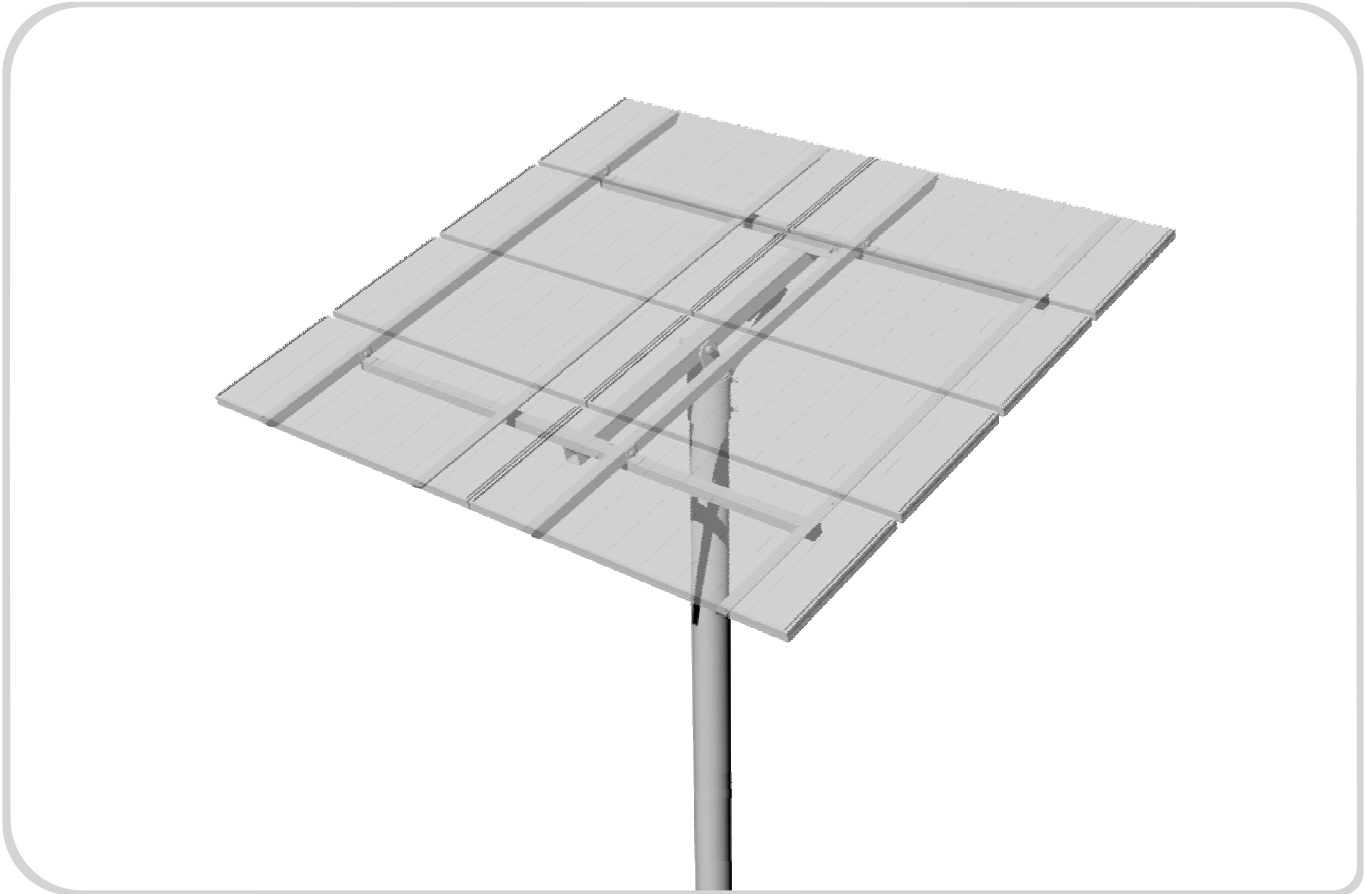

**DPW** | SOLAR



**PREFORMED** LINE PRODUCTS



## Top-of-Pole Mount for 8 Modules (TPM8) For Module Type C

ASSEMBLY INSTRUCTIONS

step-by-step  
assembly and installation

Blue Pacific Solar™



[www.BluePacificSolar.com](http://www.BluePacificSolar.com)

Version 2, Rev E  
PCN 121712-32

# Top-of-Pole Mount for 8 Modules (TPM8) For Module Type C

## *A few words about the product*

The TPM8 for module type C is designed to mount on 6 inch SCH40/80 galvanized steel pipe (installer supplied).

Pipe size and foundation requirements are based on several factors including the array surface area, maximum design wind speed, exposure category, soil type, steepest expected tilt angle, and above-ground clearance.

For foundation and pipe size recommendations on a specific installation, please contact us at:

Phone: 800-260-3792

Email: [info@power-fab.com](mailto:info@power-fab.com)

## *About these Assembly Instructions*

### *These instructions...*

- Are intended to be used by individuals with sufficient technical skills for the task. Knowledge and use of hand tools, measuring devices and torque values is also required.
- Include various precautions in the forms of Notes, Cautions, and Warnings. These are to assist in the assembly process and/or to draw attention to the fact that certain assembly steps may be dangerous and could cause serious personal injury and/or damage to components. Following the step-by-step procedures and these precautions should minimize the risk of any personal injury or damage to components while making the installation not only safe but an efficient process.

### **WARNING:**

Follow the procedures and precautions in these instructions carefully.

## *Required Tools*

- 7/16 inch wrench or socket for 1/4 inch module hardware
- 9/16 inch wrench or socket for 3/8 inch hardware
- 3/4 inch wrench or socket for 1/2 inch hardware
- 1-1/8 inch wrench or socket for 3/4 inch Pivot Bolt hardware
- Torque wrench
- Ratchet wrench
- Ratchet extension bar
- 3 to 6 foot level
- Tape Measure
- Square

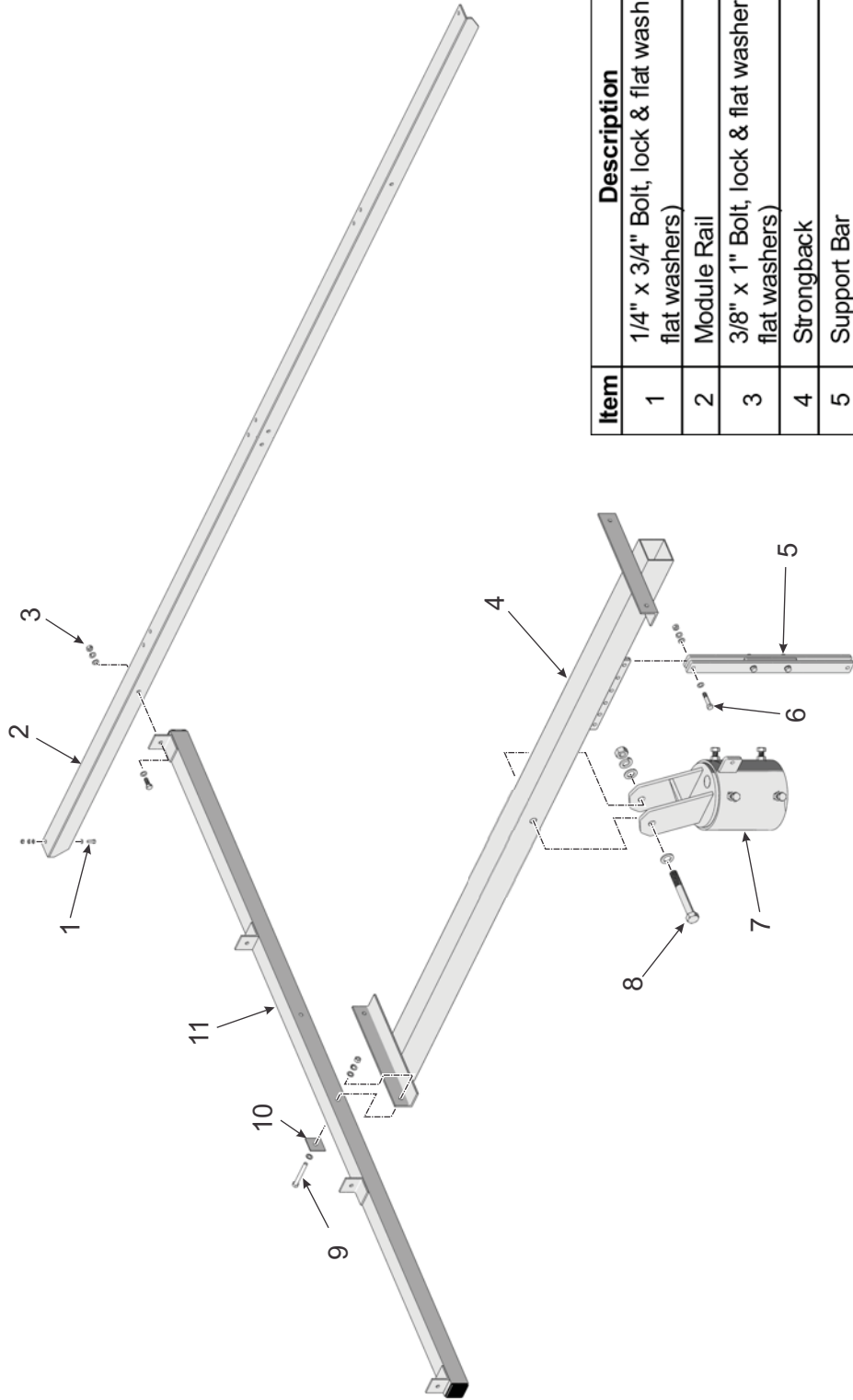

Item	Description	Qty
1	1/4" x 3/4" Bolt, lock & flat washers (2 flat washers)	32 sets
2	Module Rail	4
3	3/8" x 1" Bolt, lock & flat washers (2 flat washers)	8 sets
4	Strongback	1
5	Support Bar	1
6	3/8" x 1 3/4" Bolt, lock & flat washers (2 flat washers)	2 sets
7	Mounting Sleeve	1
8	3/4" x 5-1/2" Pivot Bolt, lock & flat washers (2 flat washers)	1 set
9	3/8" x 3 1/4" Bolt, lock & flat washers (2 flat washers)	4 sets
10	3/8" Square washer	4
11	Cross Bar	2

**Top-of-Pole Mount Parts Identification**

**CAUTION:**

Use care while working around the structure during assembly. There could be components that create hazards or obstruct free movement causing serious bodily injury. Many are at head/eye level. Move slowly and with care around the work area.

**Step 1: Install the Mounting Sleeve on Vertical Pipe**

Before installing the Mounting Sleeve, verify that the Mounting Pole is plumb to the ground and hasn't shifted or leaned while the concrete footing has cured.

The Mounting Sleeve slips on top of the Mounting Pole and has four 1/2" Set Bolts which are used to secure it to the Mounting Pole. (See Figure 1-1)

- A. Slip the Mounting Sleeve on top of Mounting Pole and slide it down until it rests/bottoms out on top of Mounting Pole.
- B. Rotate the Mounting Sleeve so the Support Bar Pivot Tab is pointing north and the Strongback Vertical Towers are leaning south.
- C. Secure the Mounting Sleeve by tightening the four 1/2" Set Bolts. **Torque each Set Bolt to 55-60 ft.-lbs.**

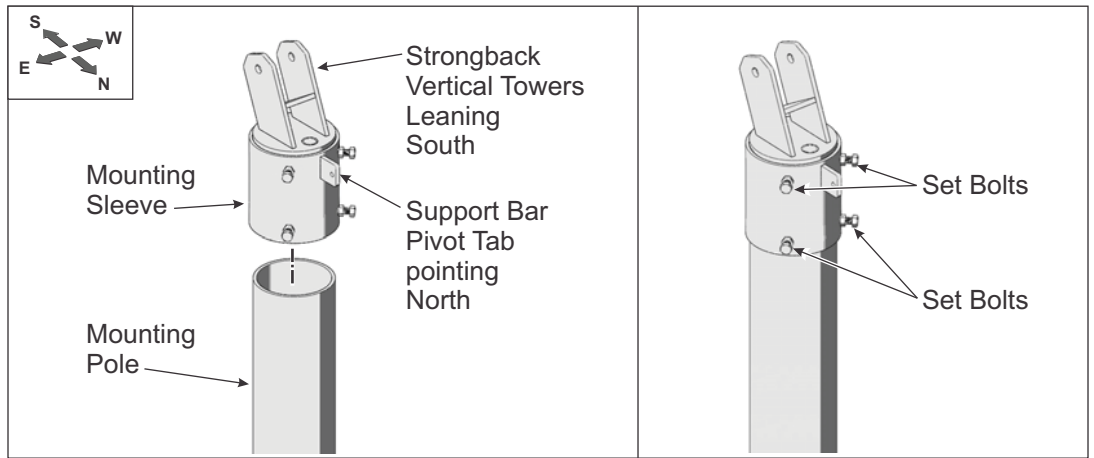

Figure 1-1: Installing the Mounting Sleeve

**Step 2: Install the Strongback to the Mounting Sleeve**

The Strongback is attached to the Mounting Sleeve using the Pivot Bolt that passes through its two Vertical Towers and the Support Bar. The Support Bar is attached to the Strongback on one end and the Support Bar Pivot Tab of the Mounting Sleeve on the other end using 3/8" hardware.

- A. Remove the Support Bar from the Strongback and re-install in the 15° elevation set point. Secure with the 3/8" hardware and finger tighten. (See Figure 2-1)

**NOTE:**

Although this system offers six elevation set points, for ease of assembly, set the angle to its lowest setting of 15-degrees. Optimum tilt setting of the rack will take place later in these instructions.

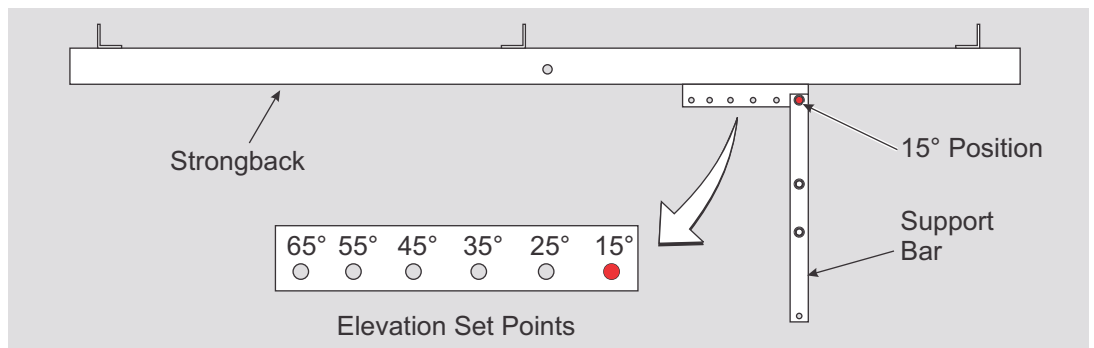
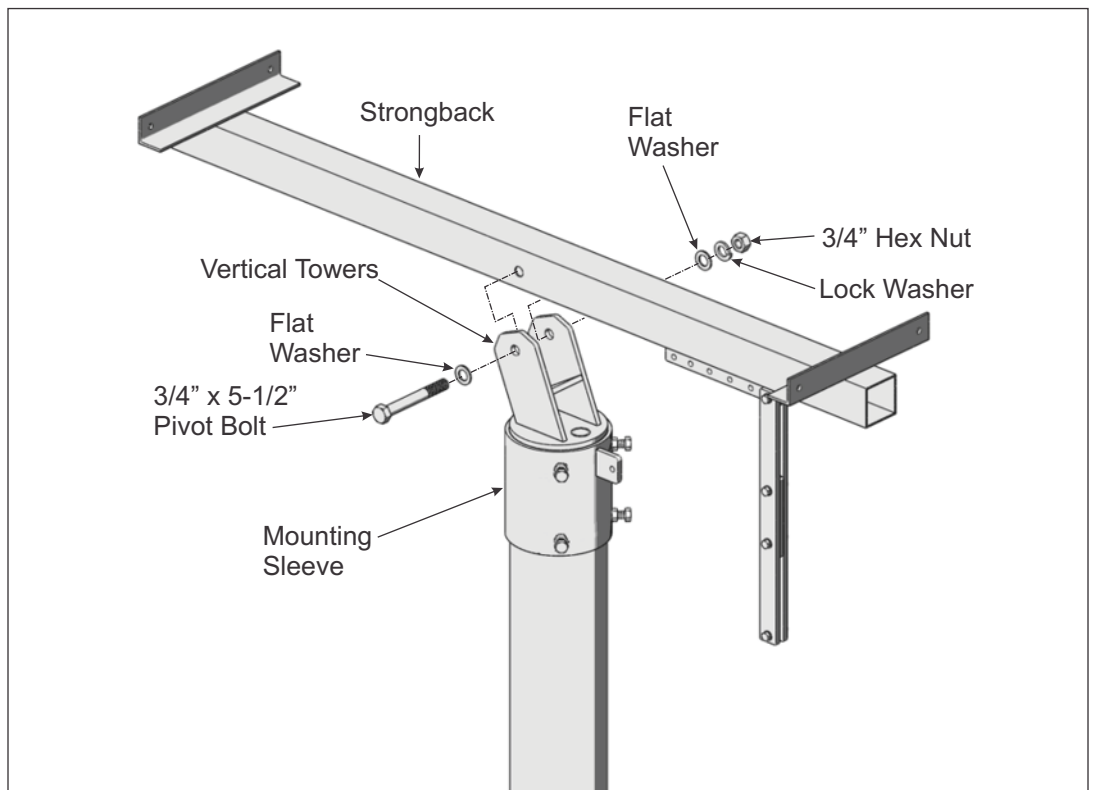

Figure 2-1: Positioning Support Bar

**CAUTION:**

This is a two person activity. The Strongback must be held in place by one person while the second person aligns it and secures it to the Mounting Sleeve using the Pivot Bolt and the 1/2" hardware. Failure to do so could lead to serious personal injury.

- B. Remove the Pivot Bolt from the Mounting Sleeve and also collect the 3/8" x 1-3/4" bolt, flat washers and lock washer needed to secure the Support Bar to its Pivot Tab on the Mounting Sleeve. (See Figure 2-2)
- C. Orient the Strongback to the Mounting Sleeve with its Lower Support Bar positioned on the same side of the Mounting Sleeve as the Support Bar Pivot Tab.
- D. Slide the Strongback between the two vertical mounting tabs, aligning the thru-hole of the Strongback with the holes of the two Vertical Towers.
- E. Insert the Pivot Bolt along with one flat washer through the one Vertical Tower and the Strongback exiting the second Vertical Tower on the opposite side. Secure with the remaining flat washer, lock washer and hex nut. For now, finger tighten only to allow movement for the next step.



*Figure 2-2: Installing the Strongback*

- F. Pivot the Strongback and the Support Bar to align the mounting holes of the Support Bar with its Pivot Tab on the Mounting Sleeve. Slide the Support Bar over the Pivot Tab. Insert the 3/8" x 1-3/4" bolt and one flat washer through the Support Bar and Mounting Tab and secure it with the remaining flat washer, lock washer and hex nut. **Torque hardware on both ends of Support Bar at 32-34 ft.-lbs.** (See Figure 2-3)
- G. Return and tighten the Pivot Bolt. The Pivot Bolt cannot be left loose - the Mounting Sleeve Vertical Towers must be firmly clamped to the sides of the Strongback eliminating any gaps between the Vertical Towers and the Strongback. **Torque to 125-150 ft.-lbs.** (See Figure 2-4)

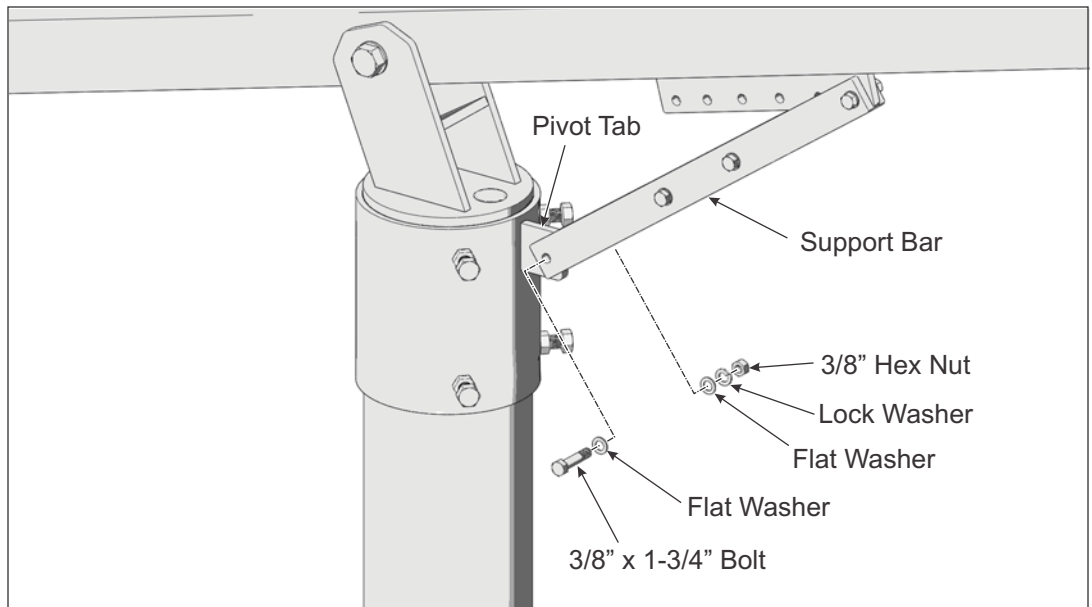

Figure 2-3: Securing Support Bar to Mounting Sleeve

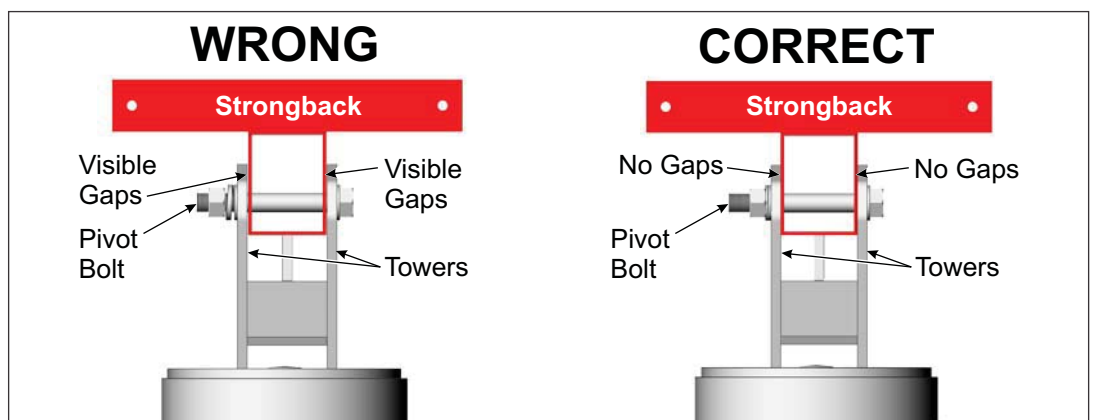

Figure 2-4: Tighten and Torque the Pivot Bolt

**CAUTION:**  
This is a two person activity. Cross-Bars are long and unstable before they are fully secured to the Strongback. Cross-Bars must be held in place by one person while the second person aligns and secures them to the Strongback. Failure to do so could lead to serious personal injury.

**Step 3: Install the Cross-Bars to the Strongback**

Cross-Bars run in an E-W direction and are secured to the Strongback mounting angles using 3/8” square flat washers along with 3/8” x 3-1/4” bolts and hardware. There are two Cross-Bars to be installed.

Cross-Bars are mounted to the outside of the Strongback mounting angles they do not nest into the Mounting Angles. (See Figure 3-1)

**Installing the Cross-Bars**

- A. Position the Cross-Bar on the outside of the mounting angle of the Strongback. Align the mounting holes and secure using 3/8” flat and square washers along with the 3/8” x 3-1/4” bolts and lock washer placing the square flat washer against the Cross-Bar. Tighten hardware and **Torque to 30-32 ft.-lbs.** (See Figure 3-2)
- B. Install the other Cross-Bar to the Strongback using the same procedure. Refer to Figure 3-1 as needed for proper positioning.

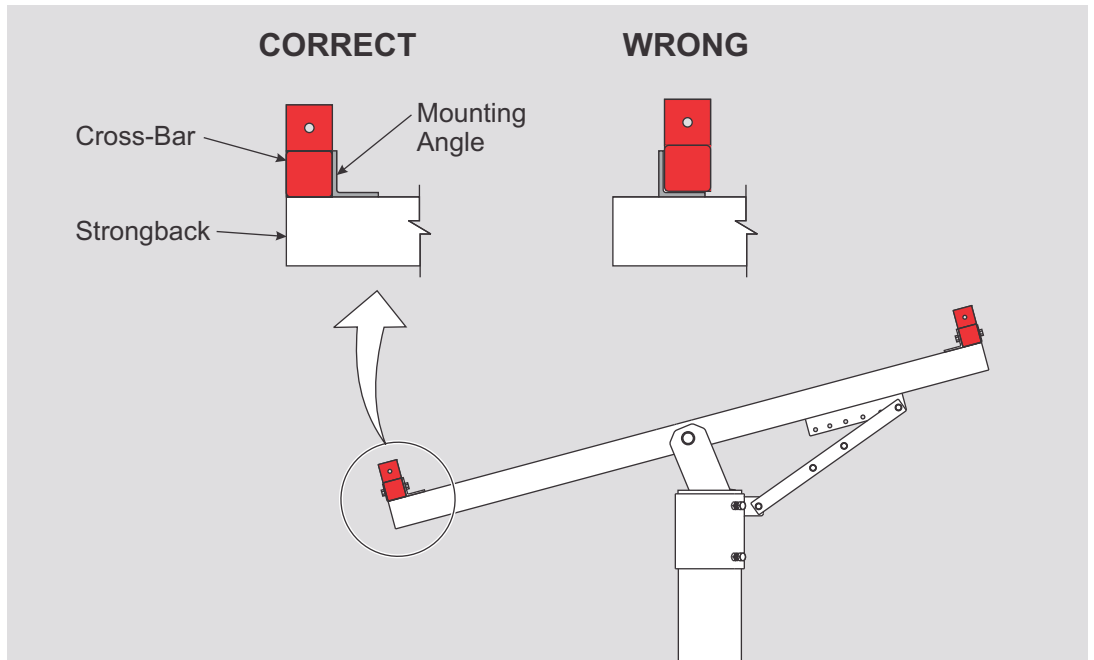

Figure 3-1: Cross-Bar Positioning relative to Mounting Angles

**CAUTION:**  
Be sure to place the 3/8" square washers on the surface of the Cross-Bar and not the Mounting Angles of the Strongback. Failure to do so will damage the surface of the Cross-Bar when the attaching hardware is tightened.

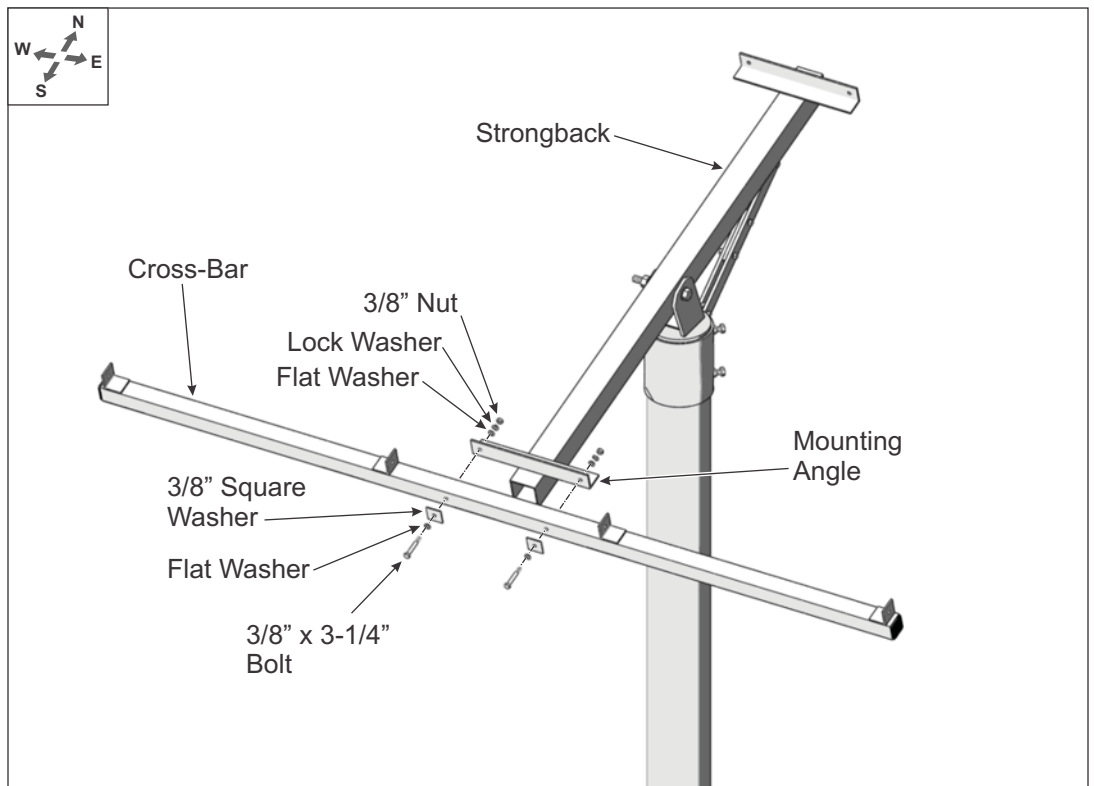

Figure 3-2: Installing Cross-Bars on the Strongback

### Step 4: Install the Module Rails to the Cross-Bars

**CAUTION:**

This is a two person activity. Module Rails are unstable before they are fully secured to the Cross-Bars. Module Rails must be held in place by one person while the second person aligns and secures them to the Cross-Bars. Failure to do so could lead to serious personal injury.

Module Rails run in an N-S direction and are secured to the Cross-Bar mounting tabs using 3/8" x 1" bolts and hardware. There are four Module Rails to be installed.

Module Rails are installed differently depending on whether they are mounted inboard or on the outer edges of the Cross-Bars. (See Figure 4-1)

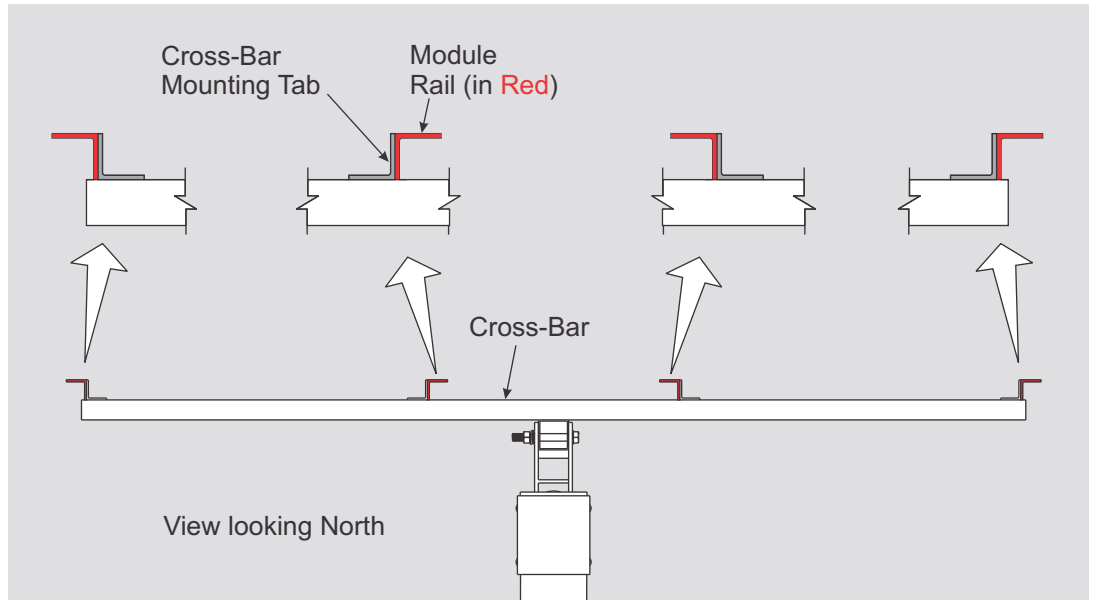

Figure 4-1: Orientation of Module Rails to Cross-Bars

**Start by installing the inboard sections of Module Rail first and work outward**

- A. Referring to Figure 4-1 for orientation of the inboard Module Rails, position the first section of Module Rail. Align the Module Rail mounting holes with the holes of the Cross-Bar mounting tabs and secure with 3/8" x 1" bolts and hardware. Each Module Rail has two attachment points. Finger-tighten for now. (See also Figure 4-2)
- B. Now install the opposite inboard Module Rail following the above procedure. Refer to Figure 4-1 as needed for orientation of the Module Rail.

**Next, install the outboard Module Rails**

- A. Referring to Figure 4-1 for orientation of the outboard Module Rails, position the first Module Rail. Align the Module Rail mounting holes with the holes of the Cross-Bar mounting tabs and secure with 3/8" x 1" bolts and hardware; each Module Rail has two attachment points. Finger-tighten for now. (See also Figure 4-3)
- B. Now install the opposite outboard Module Rail following the above procedure. Refer to Figure 4-1 as needed for orientation of the Module Rail.



**NOTE:**  
Finger-tighten the Module Rails to the Cross-Bars while installing. When all Module Rails are installed, re-tighten to specified torque values.

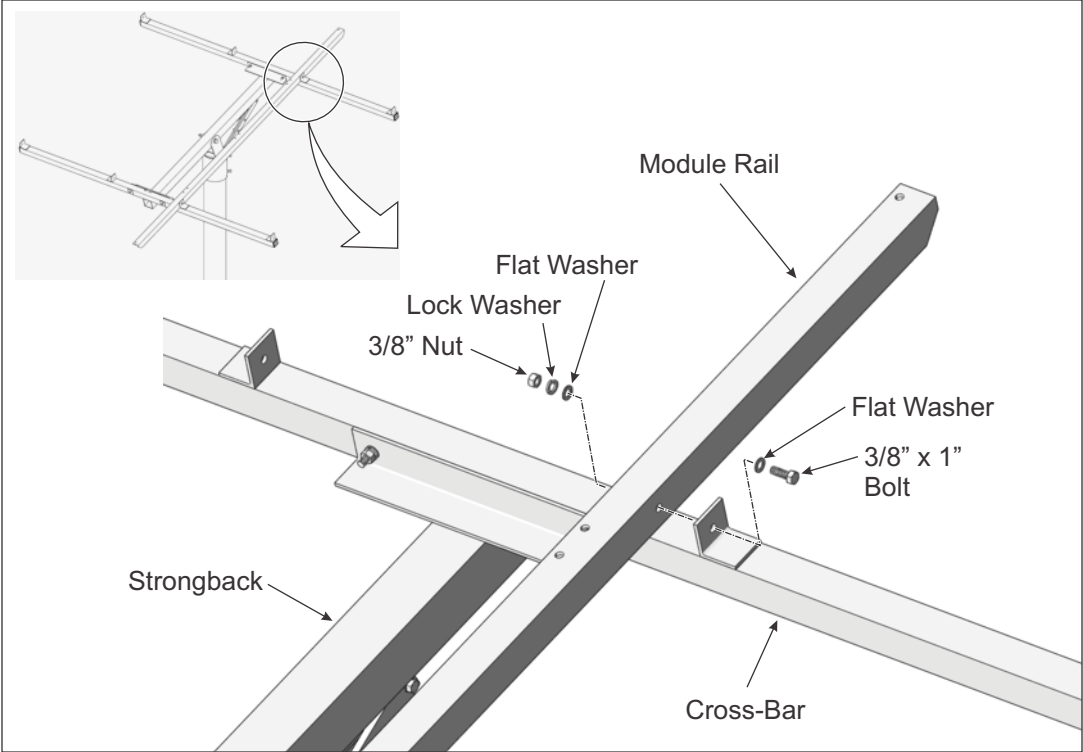

Figure 4-2: Installing Inboard Module Rails to Cross-Bars

**NOTE:**  
Double check the orientation of inboard to outboard Module Rails. If they are installed differently from these instructions the mounting holes will not align to the holes of the PV Modules.

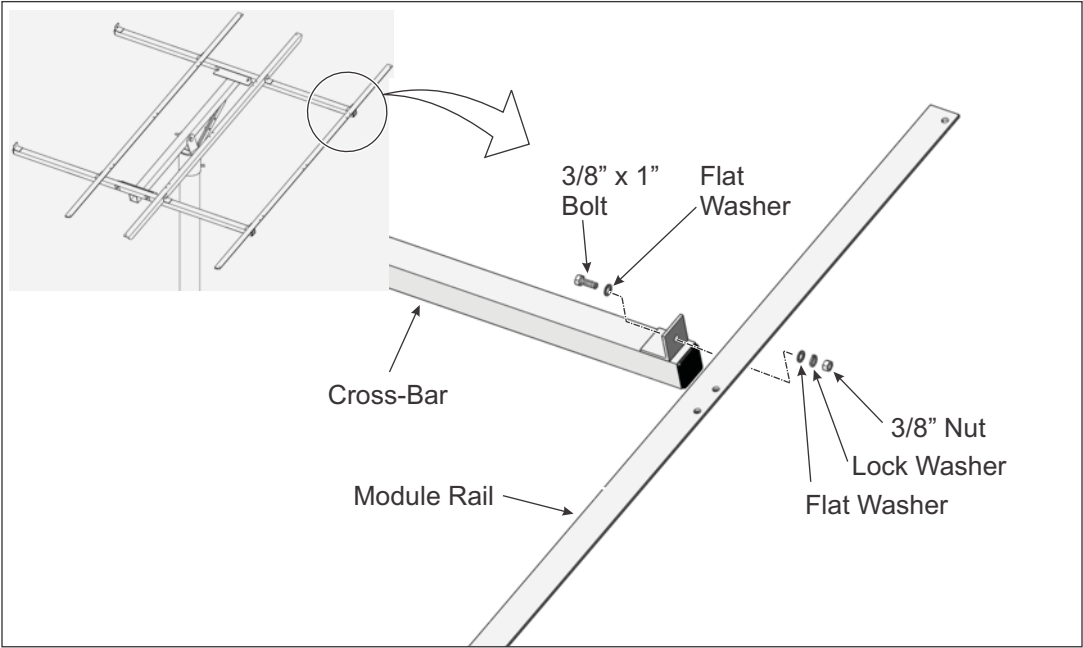

Figure 4-3: Installing Outboard Module Rails to Cross-Bars

### Step 5: Installing PV Modules to Module Rails

PV Modules are secured to the Module Rails using 1/4" x 3/4" bolts and hardware.

Start with the southern most PV Modules and work in a northern direction. This provides a measure of safety as the previously installed southern Modules can help to hold the next in-line northern Module in place during installation.

- A. Place the southern most PV Module in place on the Module Rails. Align the mounting holes and secure with 1/4" x 3/4" bolts and hardware. Each Module has four attachment points. Finger-tighten for now. (See Figure 5-1)
- B. Continue in this manner to install all southern most PV Modules first and then work in a northern direction installing the remaining Modules.

**CAUTION:**

This is a two person activity. PV Modules are heavy and unstable before they are fully secured to the Module Rails. PV Modules must be held in place by one person while the second person aligns and secures them to the Module Rails. Failure to do so could lead to serious personal injury and damaged components.

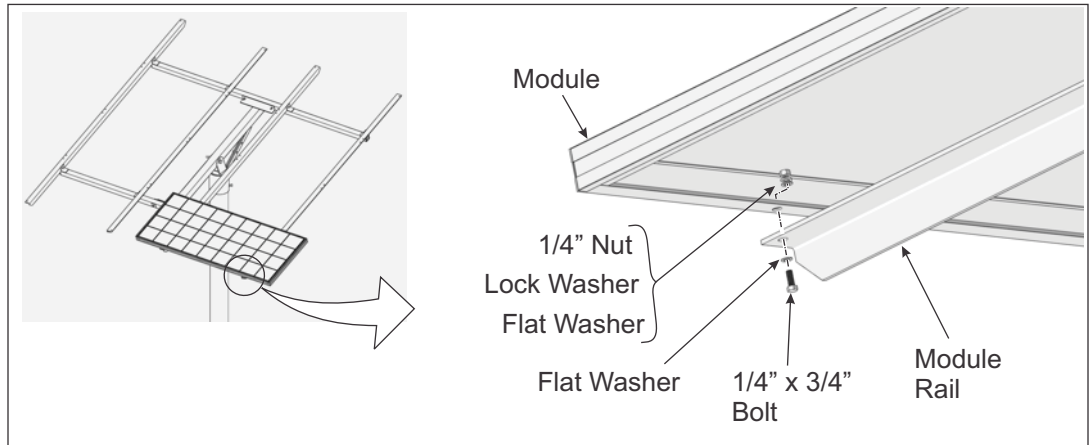

Figure 5-1: Installing PV Modules to Module Rails

### Step 6: Now return and tighten mounting hardware

- A. Return and tighten each set of the 3/8" mounting hardware, securing the Module Rails to the Cross-Bars. **Torque all at 32-34 ft.-lbs.**
- B. Return and tighten each set of 1/4" mounting hardware, securing the PV Modules to the Module rails. **Torque all at 6-8 ft.-lbs.**

### Step 7: Adjust the Tilt Angle of the Rack

To adjust the tilt angle, loosen the Pivot Bolt hardware and removing the Support Arm upper hardware attaching the Support Arm to the Strongback. Use great care in this procedure as it can be dangerous if the procedure is not completed as described with a minimum of two people.

- A. While one person holds the south edge of rack, the other loosens the Pivot Bolt and removes the upper 3/8" hardware attaching the Support Bar to the Strongback. (See Figure 7-1)
- B. Tilt the rack to the desired elevation angle (15°, 25°, 35°, 45°, 55°, or 65°) and re-attach the Support Bar to the Strongback placing the 3/8" hardware in the appropriate hole matching the desired elevation. **Torque to 32-34 ft.-lbs.** (See Figure 7-2)

**CAUTION:**

Be certain re-tighten all Module Rail and PV Module mounting hardware and torque to the specified values. Failure to do so could lead to structural failure, damaged components and/or serious personal injury.

**CAUTION:**

Do not attempt to remove the Pivot Bolt during tilt adjustments! Removal could lead to serious personal injury or death. Adjustments are made with the Pivot Bolt hardware loosened but in place.

**CAUTION:**

This is a two person activity. As the Pivot Bolt is loosened and the Support Bar hardware is removed, the rack is heavy and unstable. The rack must be held in place by one person while the second person loosens and removes the hardware and then re-installs/tightens the hardware back in place. Failure to do so could lead to serious personal injury and damaged components.

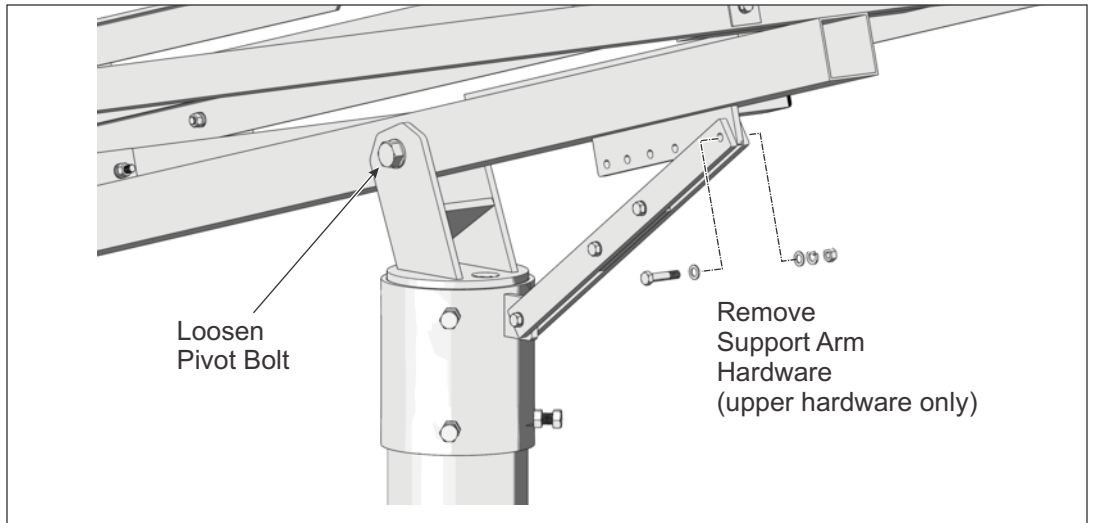

Figure 7-1: Preparing to Adjust the Tilt Angle

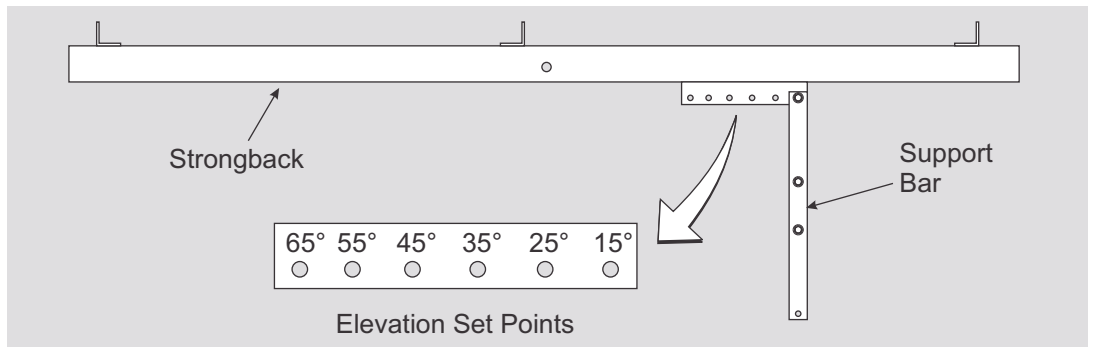

Figure 7-2: Setting the Tilt Angle

- C. Re-tighten the Pivot Bolt. After changing the tilt angle and tightening the Support Bar hardware, the Pivot Bolt must be re-tightened. The Pivot Bolt cannot be left loose - the Mounting Sleeve Vertical Towers must be firmly clamped to the sides of the Strongback eliminating any gaps between the Vertical Towers and the Strongback. **Torque to 125-150 ft.-lbs.** (See Figure 7-3)

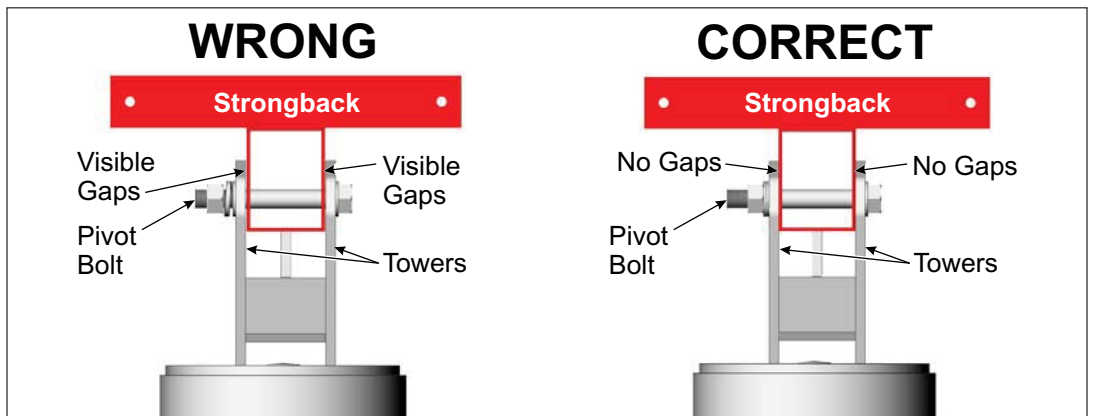

Figure 7-3: Tighten and Torque the Pivot Bolt



---

Direct Power & Water Corporation  
4000-B Vassar Drive NE  
Albuquerque, New Mexico 87107  
USA

Telephone: 800.260.3792  
Fax: 505.889.3548  
Web Site: [www.DPWSolar.com](http://www.DPWSolar.com)  
E-mail: [info@power-fab.com](mailto:info@power-fab.com)

---

Preformed Line Products  
(Canada) Limited  
1711 Bishop St. E  
Cambridge, ON N1T 1N5

Telephone: 519.740.6666  
Fax: 519.740.7917  
Web Site: [www.preformed.on.ca](http://www.preformed.on.ca)  
E-mail: [sales@preformed.on.ca](mailto:sales@preformed.on.ca)