



**DPW** | SOLAR



**PREFORMED** LINE PRODUCTS



## Top-of-Pole Mount for 4 Modules (TPM4) For Module Type C

ASSEMBLY INSTRUCTIONS

step-by-step  
assembly and installation

Blue Pacific Solar™



[www.BluePacificSolar.com](http://www.BluePacificSolar.com)

Version 2, Rev D  
PCN 121712-25

## Top-of-Pole Mount for 4 Modules (TPM4) For Module Type C

### *A few words about the product*

The TPM4 for module type C is designed to mount on 4 inch SCH40/80 galvanized steel pipe (installer supplied).

Pipe size and foundation requirements are based on several factors including the array surface area, maximum design wind speed, exposure category, soil type, steepest expected tilt angle, and above-ground clearance.

For foundation and pipe size recommendations on a specific installation, please contact us at:

Phone: 800-260-3792

Email: [info@power-fab.com](mailto:info@power-fab.com)

### *About these Assembly Instructions*

#### *These instructions...*

- Are intended to be used by individuals with sufficient technical skills for the task. Knowledge and use of hand tools, measuring devices and torque values is also required.
- Include various precautions in the forms of Notes, Cautions, and Warnings. These are to assist in the assembly process and/or to draw attention to the fact that certain assembly steps may be dangerous and could cause serious personal injury and/or damage to components. Following the step-by-step procedures and these precautions should minimize the risk of any personal injury or damage to components while making the installation not only safe but an efficient process.

#### **WARNING:**

Follow the procedures and precautions in these instructions carefully.

### *Required Tools & Publications*

- 7/16 inch wrench or socket for 1/4 inch module hardware
- 9/16 inch wrench or socket for 3/8 inch hardware
- 1-1/8 inch wrench or socket for 3/4 inch Pivot Bolt hardware
- Torque wrench
- Ratchet wrench
- Ratchet extension bar
- 3 to 6 foot level
- Tape Measure
- Square

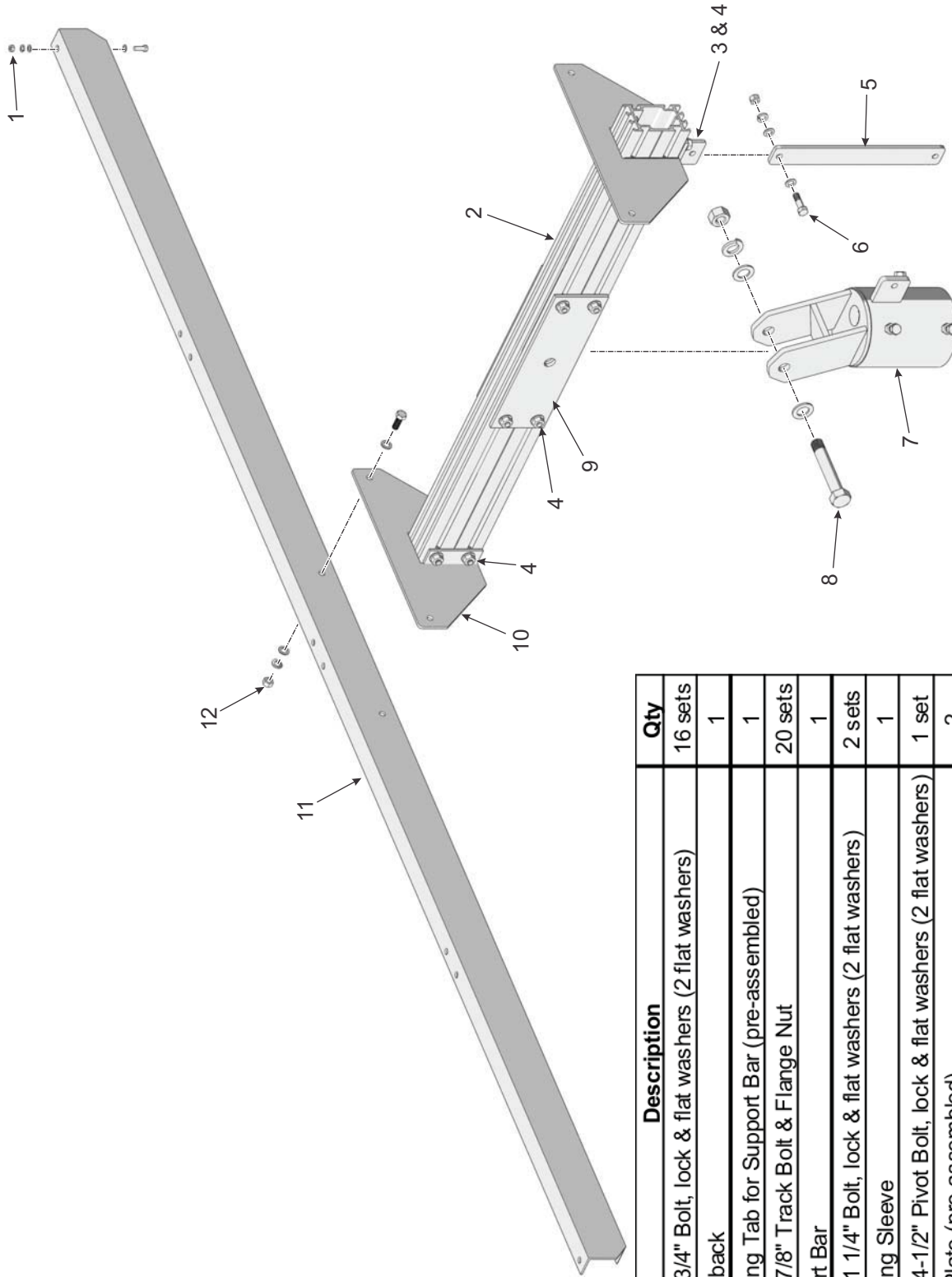

Item	Description	Qty
1	1/4" x 3/4" Bolt, lock & flat washers (2 flat washers)	16 sets
2	Strongback	1
3	Mounting Tab for Support Bar (pre-assembled)	1
4	3/8" x 7/8" Track Bolt & Flange Nut	20 sets
5	Support Bar	1
6	3/8" x 1 1/4" Bolt, lock & flat washers (2 flat washers)	2 sets
7	Mounting Sleeve	1
8	3/4" x 4-1/2" Pivot Bolt, lock & flat washers (2 flat washers)	1 set
9	Pivot Plate (pre-assembled)	2
10	Rail Bracket (pre-assembled)	2
11	Module Rail	2
12	3/8" x 1" Bolt, lock & flat washers (2 flat washers)	4 sets

**Top-of-Pole Mount for 4 Modules for Module Type C Parts Identification**

**CAUTION:**

Use care while working around the structure during assembly. There could be components that create hazards or obstruct free movement causing serious bodily injury; many at head/eye level. Move slowly and with care around the work area.

**Step 1: Install the Mounting Sleeve on Vertical Pipe**

Before installing the Mounting Sleeve verify, that the Mounting Pole is plumb to the ground and hasn't shifted or leaned while the concrete footing has cured.

The Mounting Sleeve slips on top of the Mounting Pole and has three 3/8" Set Bolts which are used to secure it to the Mounting Pole. (See Figure 1-1)

- A. Slip the Mounting Sleeve on top of Mounting Pole and slide it down until it rests/bottoms out on top of Mounting Pole.
- B. Rotate the Mounting Sleeve so the Support Bar Pivot Tab is pointing north and the Strongback Vertical Towers are leaning south.
- C. Secure the Mounting Sleeve by tightening the three 3/8" Set Bolts. **Torque each Set Bolt to 32-34 ft.-lbs.**

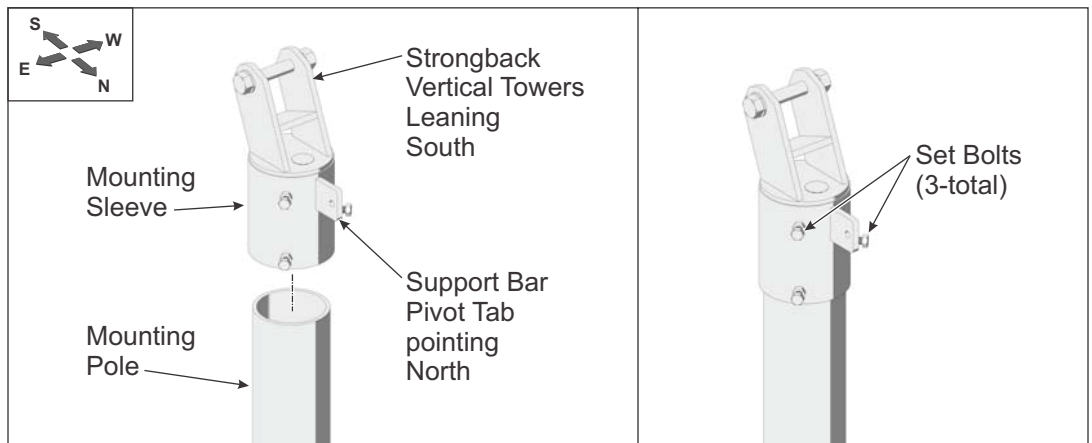

Figure 1-1: Installing the Mounting Sleeve

**Step 2: Installing the Strongback on the Mounting Sleeve**

The Strongback is attached to the Mounting Sleeve using the Pivot Bolt that passes through its two Vertical Towers and the Support Bar. The Support Bar is attached to the Mounting Tab on one end and the Support Bar Pivot Tab of the Mounting Sleeve on the other end using 3/8" hardware.

- A. Remove the Pivot Bolt from the Mounting Sleeve and also collect the 3/8" x 1-1/4" bolt, flat washers and lock washer needed to secure the Support Bar to its Pivot Tab on the Mounting Sleeve.
- B. Orient the Strongback to the Mounting Sleeve with its Support Bar positioned on the same side of the Mounting Sleeve as the Support Bar Pivot Tab.
- C. Place the Strongback between the two vertical mounting tabs, aligning the thru-hole of the Strongback with the holes of the two Vertical Towers.
- D. Insert the Pivot Bolt along with one flat washer through the one Vertical Tower and the Strongback exiting the second Vertical Tower on the opposite side. Secure with the remaining flat washer, lock washer and hex nut. For now, finger tighten only to allow movement for the next step.

**CAUTION:**

This is a two person activity. The Strongback must be held in place by one person while the second person aligns it and secures it to the Mounting Sleeve using the Pivot Bolt and Support Bar. Failure to do so could lead to serious personal injury.

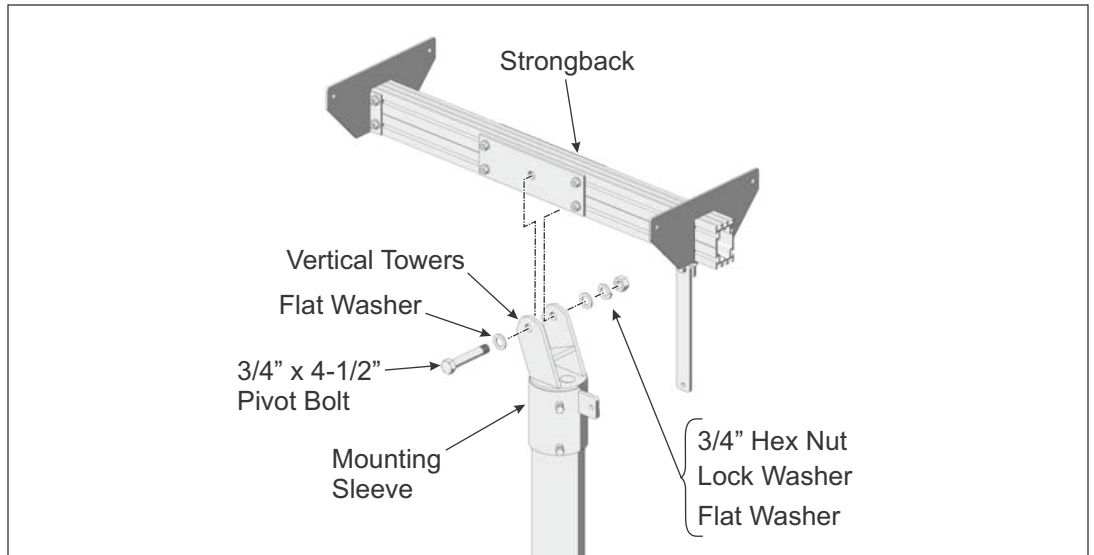

*Figure 2-1: Installing the Strongback*

For safety and ease of assembly its best to position the Strongback at 0-degrees or level to the ground. Follow these steps to level and secure the Strongback. This is a two person activity, as one person supports the Strongback while the second adjusts and secures the Strongback with the Support Bar.

- E. First loosen the four 3/8" Flange Nuts securing the Support Bar Mounting Tab to the Strongback. (See Figure 2-2)

**NOTE:**

Although this system offers variable elevation set points, for ease of assembly, set the angle to 0-degrees. Optimum tilt setting of the rack will take place later in these instructions.

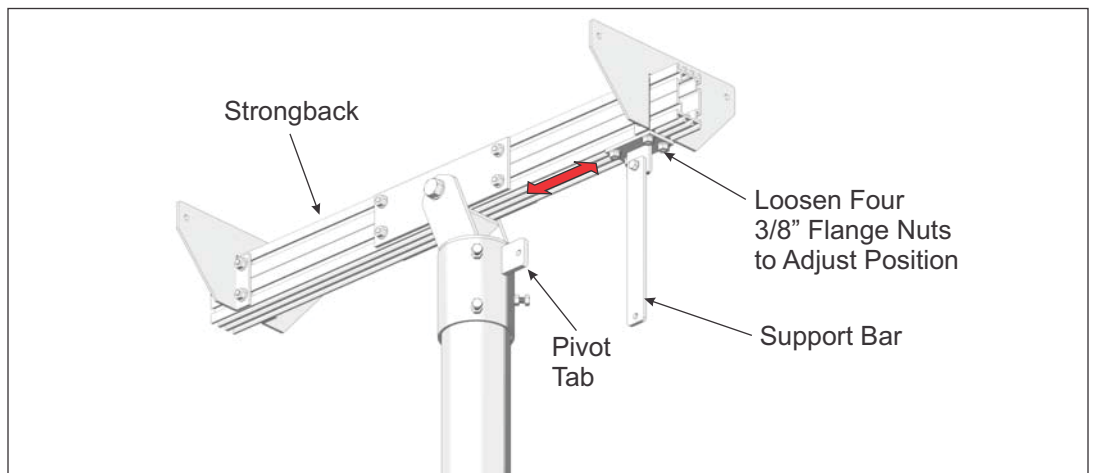

*Figure 2-2: Loosening the Support Bar Mounting Tab*

- F. Pivot the Strongback to 0-degrees (level to the ground) and hold in position.
- G. Slide the Support Bar Mounting Tab to align the mounting holes of the Support Bar with its Pivot Tab on the Mounting Sleeve. Slide the Support Bar over the Pivot Tab. Insert the 3/8" x 1-1/4" bolt and one flat washer through the Support Bar and Mounting Tab and secure it with the remaining flat washer, lock washer and hex nut. **Torque hardware on both ends of Support Bar at 32-34 ft.-lbs. Torque the 3/8" Flange Nuts at 32-34 ft.-lbs.** (See Figure 2-3)

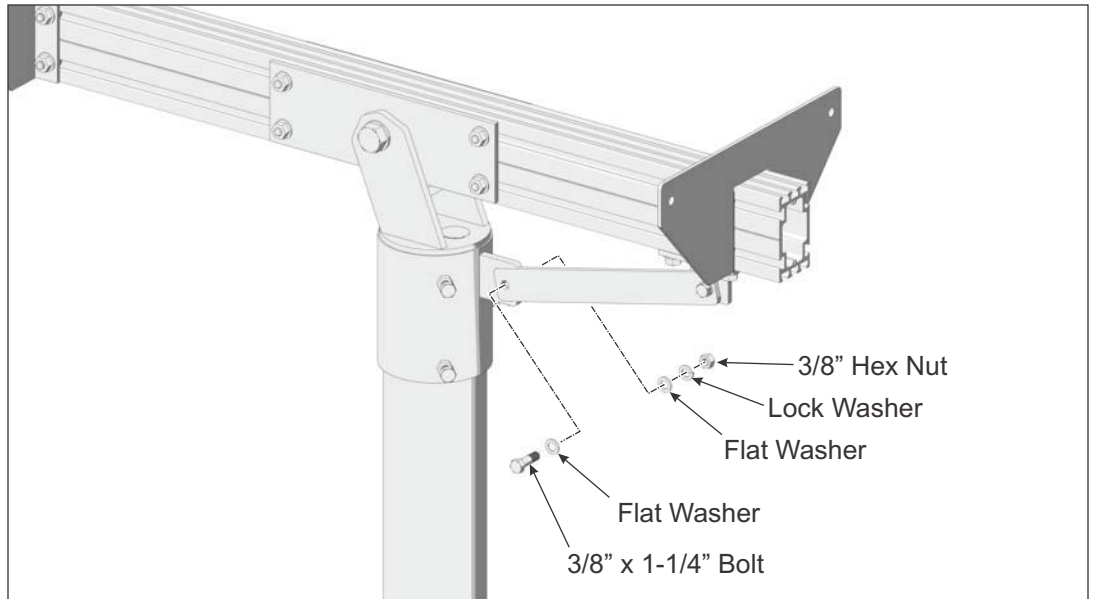

*Figure 2-3: Securing Support Bar to Mounting Sleeve*

H. Return and tighten the Pivot Bolt. The Pivot Bolt cannot be left loose - the Mounting Sleeve Vertical Towers must be firmly clamped to the sides of the Strongback eliminating any gaps between the Vertical Towers and the Strongback. **Torque to 125-150 ft.-lbs.** (See Figure 2-4)

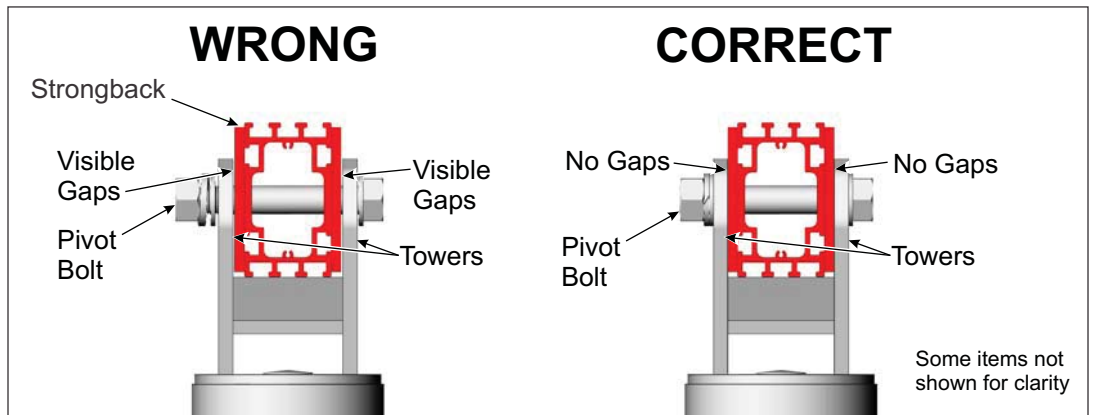

*Figure 2-4: Tighten and Torque the Pivot Bolt*

### Step 3: Install the Module Rails on the Rail Brackets

Module Rails run in an E-W direction and are secured to the Rail Brackets using 3/8" x 1" bolts and hardware. There are two Module Rails to install.

Module Rail orientation is dependent on location. Follow these instructions carefully for the correct orientation. (See Figure 3-1)

- A. Referring to Figure 3-1 for orientation of the Module Rails, position the Module Rail on the Rail Bracket. Align the Module Rail mounting holes with the holes of the Rail Bracket and secure with 3/8" x 1" bolts and hardware. Finger-tighten for now. (See also Figure 3-2)
- B. Continue in this manner and install the second Module Rail while following Figure 3-1 for proper orientation of the Rails to the Rail Brackets.

**WARNING:**

This is a two person activity. Module Rails are unstable before they are fully secured to the Rail Brackets. Module Rails must be held in place by one person while the second person aligns and secures them to the Rail Brackets. Failure to do so could lead to personal injury.

**NOTE:**

Be certain that the orientation of the Module Rails to the Rail Brackets match these instructions.

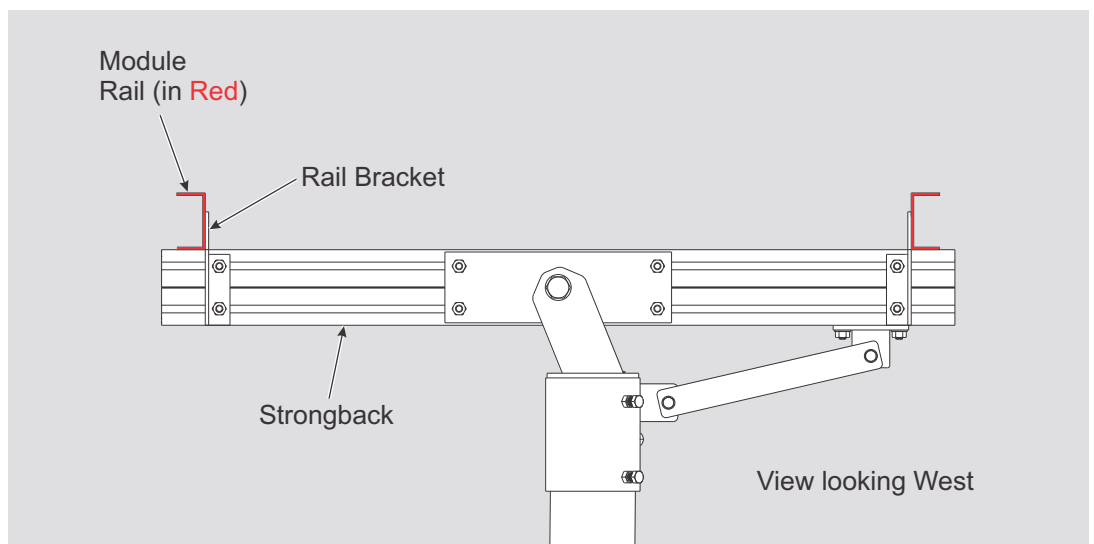

Figure 3-1: Orientation of Module Rails to Rail Brackets

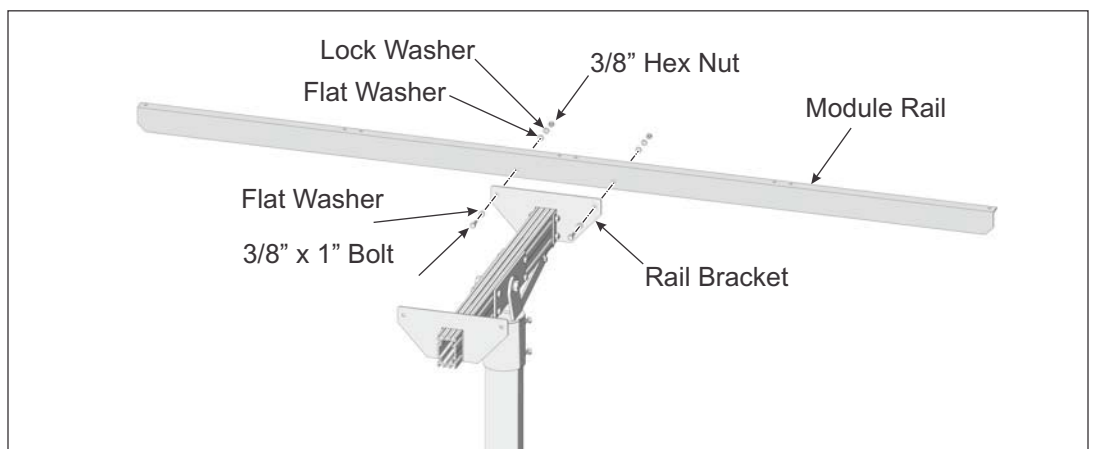

Figure 3-2: Installing Module Rails to Rail Brackets

**NOTE:**

Finger-tighten the Module Rails to the Rail Brackets while installing. After PV Modules are installed, re-tighten to specified torque values.

## Step 4: Installing PV Modules to Module Rails

PV Modules are secured to the Module Rails using 1/4" x 3/4" bolts and hardware. Start with the internal PV Modules and work outward.

- A. Place an internal PV Module on the Module Rails. Align the mounting holes and secure with 1/4" x 3/4" bolts and hardware. Each Module has four attachment points. Finger-tighten for now. (See Figure 4-1)
- B. Continue in this manner to install remaining PV Modules.

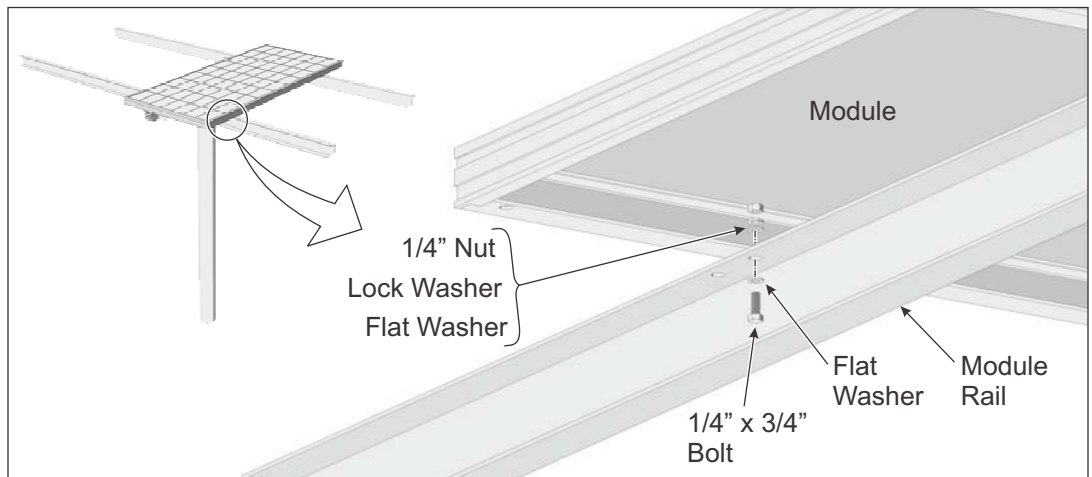

Figure 4-1: Installing PV Modules to Module Rails

## Step 5: Now return and tighten mounting hardware.

- A. Return and tighten each set of the 3/8" mounting hardware, securing the Module Rails to the Rail Brackets. **Torque all at 32-34 ft.-lbs.**
- B. Return and tighten each set of 1/4" mounting hardware, securing the PV Modules to the Module rails. **Torque all at 6-8 ft.-lbs.**

## Step 6: Adjust the Tilt Angle of the Rack

To adjust the tilt angle, loosen the Pivot Bolt, Support Bar Mounting Tab, and the two sets of hardware at the ends of the Support Bar. Use great care in this procedure as it can be dangerous if the procedure is not completed as described with a minimum of two people.

- A. While one person holds the south edge of rack, the other loosens the Pivot Bolt, the 3/8" Flange Nuts securing the Mounting Tab to the Strongback, and the 3/8" hardware at both ends of the Support Bar at the Support Bar Mounting Tab of the Strongback and the Pivot Tab of the Mounting Sleeve. (See Figure 6-1)
- B. Tilt the rack to the desired elevation angle and re-tighten the 3/8" Flange Nuts securing the Mounting Tab to the Strongback and the 3/8" hardware at both ends of the Support Bar at the Support Bar Mounting Tab of the Strongback and the Pivot Tab of the Mounting Sleeve **Torque the 3/8" Flange Nuts to 32-34 ft.-lbs. and the 3/8" hardware to 32-34 ft.-lbs.**

### CAUTION:

This is a two person activity. PV Modules are heavy and unstable before they are fully secured to the Module Rails. PV Modules must be held in place by one person while the second person aligns and secures them to the Module Rails. Failure to do so could lead to serious personal injury and damaged components.

### CAUTION:

Be certain to re-tighten all Module Rail and PV Module mounting hardware and torque to the specified values. Failure to do so could lead to structural failure, damaged components and/or serious personal injury.

### WARNING:

Do not attempt to remove the Pivot Bolt during tilt adjustments! Removal could lead to serious personal injury or death. Adjustments are made with the Pivot Bolt hardware loosened but in place.



**CAUTION:**

This is a two person activity. As the hardware is loosened, the rack is heavy and unstable. The rack must be held in place by one person while the second person loosens the hardware and then re-installs and tightens the hardware back in place. Failure to do so could lead to serious personal injury and damaged components.

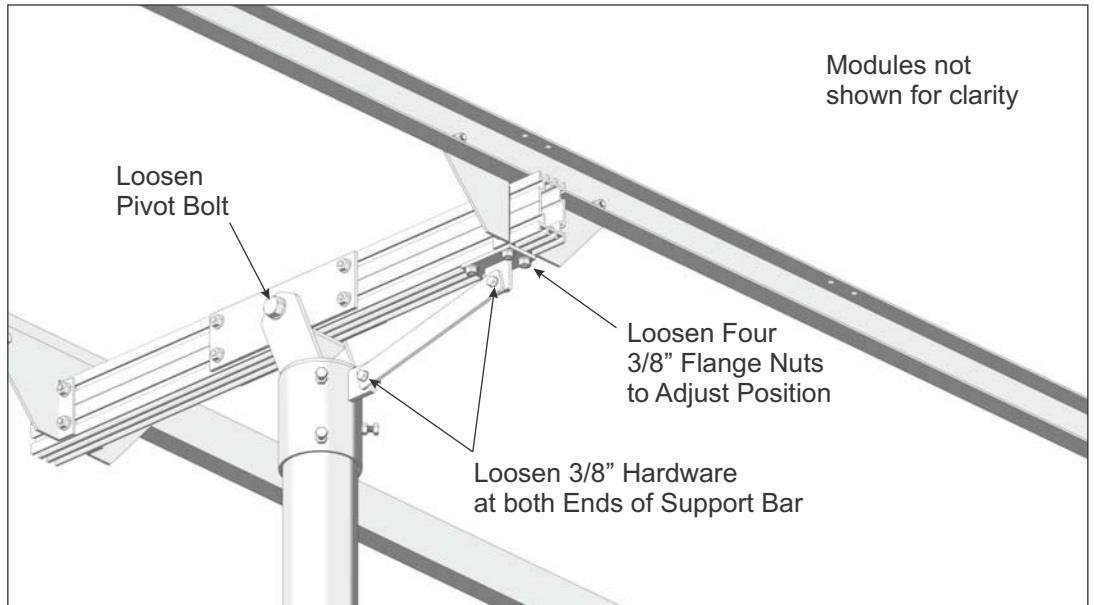

Figure 6-1: Adjusting Tilt Angle

- C. Re-tighten the Pivot Bolt. After changing the tilt angle and tightening the Support Bar hardware, the Pivot Bolt must be re-tightened. The Pivot Bolt cannot be left loose - the Mounting Sleeve Vertical Towers must be firmly clamped to the sides of the Strongback eliminating any gaps between the Vertical Towers and the Strongback. **Torque to 125-150 ft.-lbs.** (See Figure 6-2)

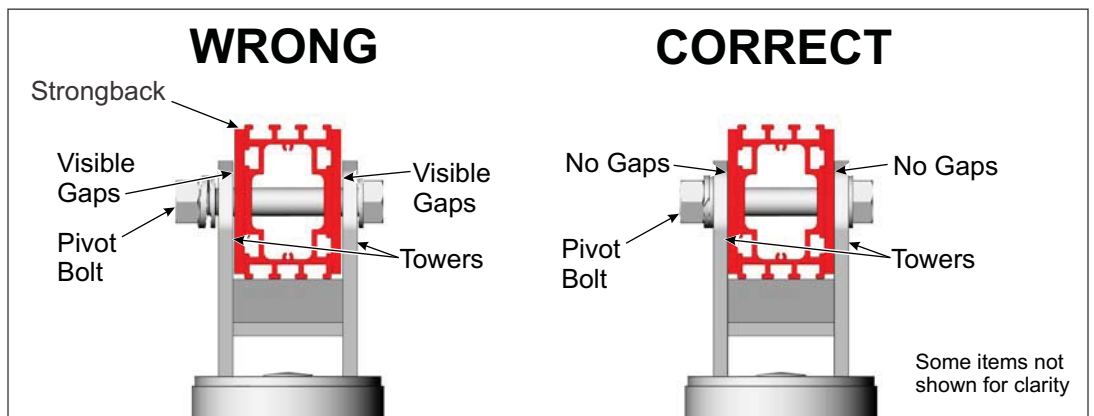

Figure 6-2: Tighten and Torque the Pivot Bolt



---

Direct Power & Water Corporation  
4000-B Vassar Drive NE  
Albuquerque, New Mexico 87107  
USA

Telephone: 800.260.3792  
Fax: 505.889.3548  
Web Site: [www.DPWSolar.com](http://www.DPWSolar.com)  
E-mail: [info@power-fab.com](mailto:info@power-fab.com)

Preformed Line Products  
(Canada) Limited  
1711 Bishop St. E  
Cambridge, ON N1T 1N5

Telephone: 519.740.6666  
Fax: 519.740.7917  
Web Site: [www.preformed.on.ca](http://www.preformed.on.ca)  
E-mail: [sales@preformed.on.ca](mailto:sales@preformed.on.ca)