



**DPW** | SOLAR



**PREFORMED** LINE PRODUCTS



## Top-of-Pole Mount for 1 Module (TPM1) For Module Types A, B, C, D, E, F, & G

ASSEMBLY INSTRUCTIONS

step-by-step  
assembly and installation

Blue Pacific Solar™



[www.BluePacificSolar.com](http://www.BluePacificSolar.com)

Version 2, Rev D  
PCN 121712-1

## Top-of-Pole Mount for 1 Module (TPM1) For Module Types A, B, C, D, E, F, & G

### *A few words about the product*

The TPM1 for module types A, B, C, D, E, F, & G is designed to mount on 2 inch SCH40/80 galvanized steel pipe (installer supplied).

Pipe size and foundation requirements are based on several factors including the array surface area, maximum design wind speed, exposure category, soil type, steepest expected tilt angle, and above-ground clearance.

For foundation and pipe size recommendations on a specific installation please contact us at:

Phone: 800-260-3792

Email: [info@power-fab.com](mailto:info@power-fab.com)

### *About these Assembly Instructions*

#### *These instructions...*

- Are intended to be used by individuals with sufficient technical skills for the task. Knowledge and use of hand tools, measuring devices and torque values is also required.
- Include various precautions in the forms of Notes, Cautions, and Warnings. These are to assist in the assembly process and/or to draw attention to the fact that certain assembly steps may be dangerous and could cause serious personal injury and/or damage to components. Following the step-by-step procedures and these precautions should minimize the risk of any personal injury or damage to components while making the installation not only safe but an efficient process.

#### **WARNING:**

Follow the procedures and precautions in these instructions carefully.

### *Required Tools*

- 7/16 inch wrench or socket for 1/4 inch module hardware
- 9/16 inch wrench or socket for 3/8 inch hardware
- 3/4 inch wrench or socket for 1/2 inch hardware
- Torque wrench
- Ratchet wrench
- Ratchet extension bar
- 3 to 6 foot level
- Tape Measure
- Square

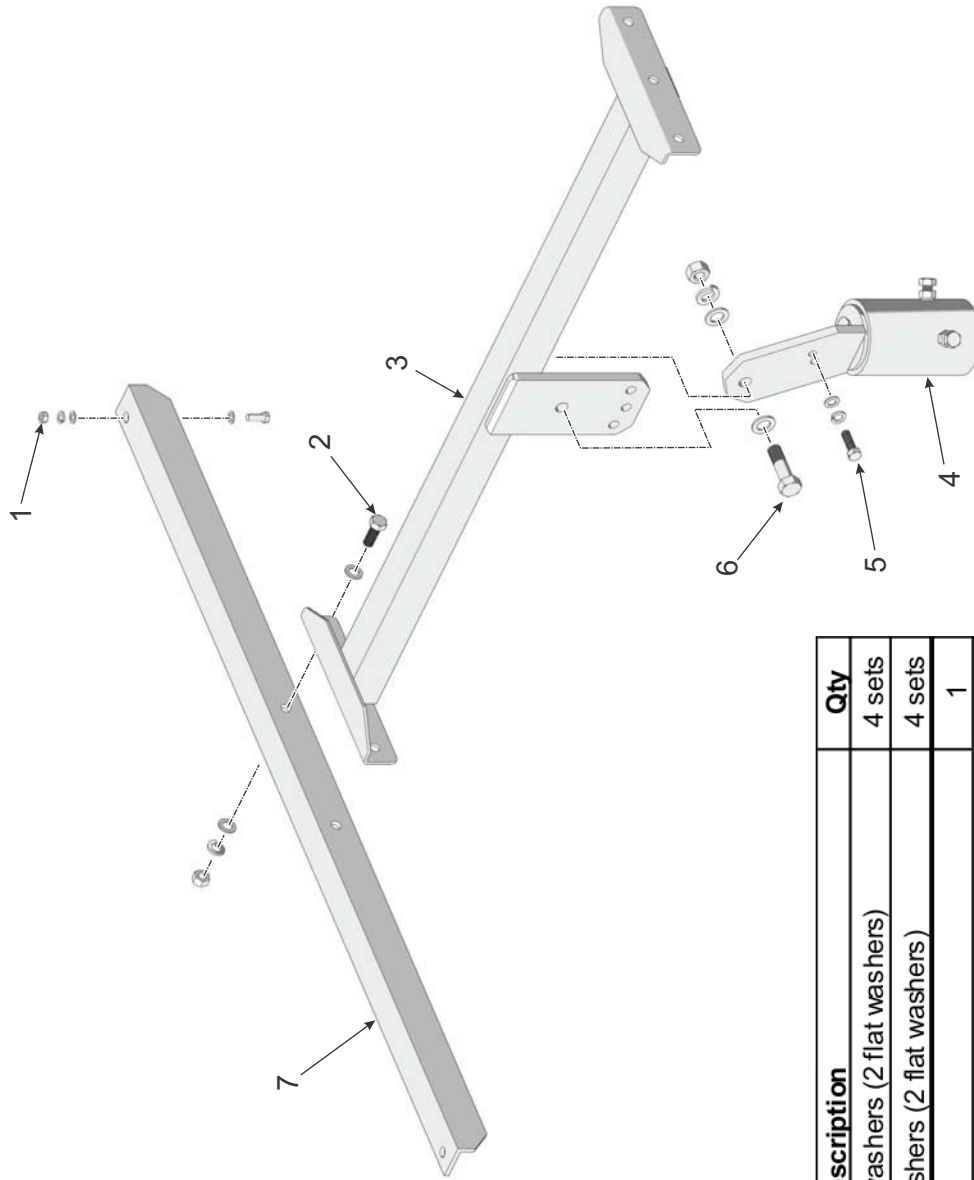

Item	Description	Qty
1	1/4" x 3/4" Bolt, lock & flat washers (2 flat washers)	4 sets
2	3/8" x 1" Bolt, lock & flat washers (2 flat washers)	4 sets
3	Strongback	1
4	Mounting Sleeve	1
5	5/16" x 1" Lock Bolt, lock & flat washer	1 set
6	1/2" x 1-3/4" Pivot Bolt, nut, lock & flat washers (2 flat washers)	1 set
7	Module Rail	2

**Top-of-Pole Mount for 1 Module for Module Types A, B, C, D, E, F, & G Parts Identification**

## Step 1: Install the Mounting Sleeve on Vertical Pipe

Before installing the Mounting Sleeve, verify that the Mounting Pole is plumb to the ground and hasn't shifted or leaned while the concrete footing has cured.

The Mounting Sleeve slips on top of the Mounting Pole and has two 3/8" Set Bolts which are used to secure it to the Mounting Pole.

- A. Slip the Mounting Sleeve on top of Mounting Pole and slide it down until it rests/bottoms out on top of Mounting Pole.
- B. Rotate the Mounting Sleeve so the Strongback Vertical Tower is leaning south.
- C. Secure the Mounting Sleeve by tightening the two 3/8" Set Bolts. **Torque each Set Bolt to 32-34 ft.-lbs.** (See Figure 1-1)

**CAUTION:**

Use care while working around the structure during assembly. There could be components that create hazards or obstruct free movement, causing serious bodily injury. Many of these are at head/eye level. Move slowly and with care around the work area.

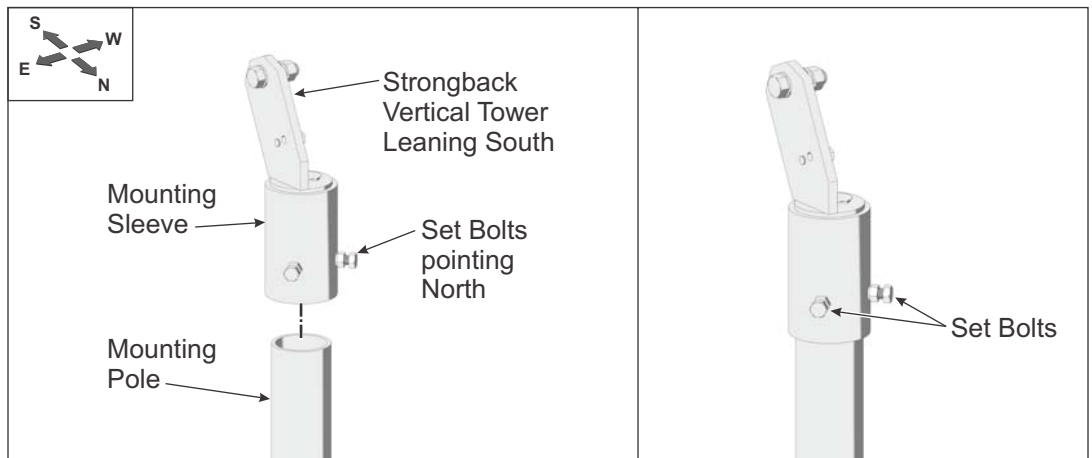

Figure 1-1: Installing the Mounting Sleeve

## Step 2: Install the Strongback to the Mounting Sleeve

The Strongback gets attached to the Mounting Sleeve using a Pivot Bolt that passes through the Vertical Tower of the Mounting Sleeve and the Pivot Plate of the Strongback. Additionally, a 5/16" x 1" Lock Bolt is used to set the elevation and further secure the Strongback to the Mounting Sleeve Vertical Tower.

The system provides elevation set points of 5°, 15°, 25°, 35°, 45°, or 55° and does so by the combination of two Lock Bolt Locations and three Lock Points. The Lock Bolt Locations are the threaded holes on the Vertical Tower and accept the 5/16" x 1" Bolt. The Lock Points are located on the Strongback Pivot Plate. Figure 2-1 shows the combinations of Lock Bolt Location to Lock Point and desired Elevation Set Point.

As the Strongback is installed, the elevation is also temporarily set for purposes of assembly. Once assembly is complete, the elevation angle will be reset based on the preferred elevation angle of your particular installation.

### Setting the Elevation Set Point

For ease of assembly and safety, it is recommended that the elevation be set at 5°. The table in Figure 2-1 shows that for a 5° elevation the Lock Bolt Location would be "A" and the Lock Point would be "3".

**NOTE:**

Although this system offers six elevation set points, it is recommended to set the angle to its lowest setting of 5-degrees for ease of assembly. Optimum tilt setting of the rack will take place later in these instructions.

**CAUTION:**

This is a two person activity. The Strongback must be held in place by one person while the second person aligns it and secures it to the Mounting Sleeve using the Pivot Bolt and the 5/16" Anchor Bolt. Failure to do so could lead to serious personal injury.

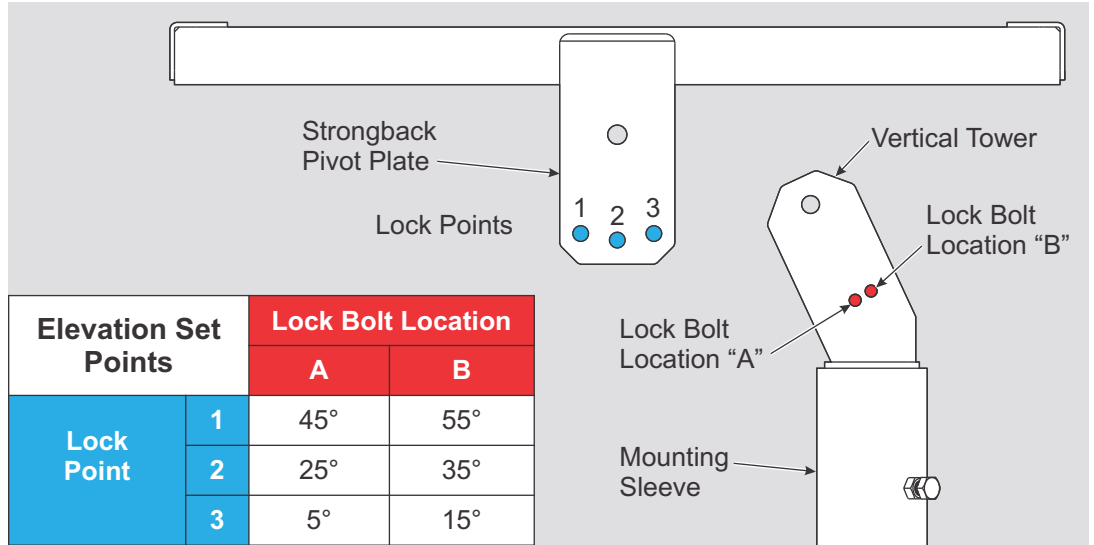

Figure 2-1: Setting Elevation Angle

- A. Remove the Pivot Bolt and 5/16" x 1" Lock Bolt and washers from the Mounting Sleeve Vertical Tower.
- B. Position the Strongback to the Mounting Sleeve Vertical Tower as shown in Figure 2-2.
- C. Insert the Pivot Bolt along with one flat washer thru the Strongback Pivot Plate and Vertical Tower. Secure with the flat washer, lock washer and hex nut. For now, finger tighten only to allow movement for the next step.
- D. Pivot the Strongback and align "Lock Bolt Location A" with "Lock Point 3". Secure position by inserting 5/16" x 1" Lock Bolt, lock and flat and washers into "Lock Point 3". **Torque to 12-14 ft.-lbs.**
- E. Tighten the Pivot Bolt. The Pivot Bolt cannot be left loose - the Mounting Sleeve Vertical Tower must be firmly clamped to the side of the Strongback eliminating any gaps between the Vertical Tower and the Strongback. **Torque to 75-85 ft.-lbs.** (See Figure 2-3)

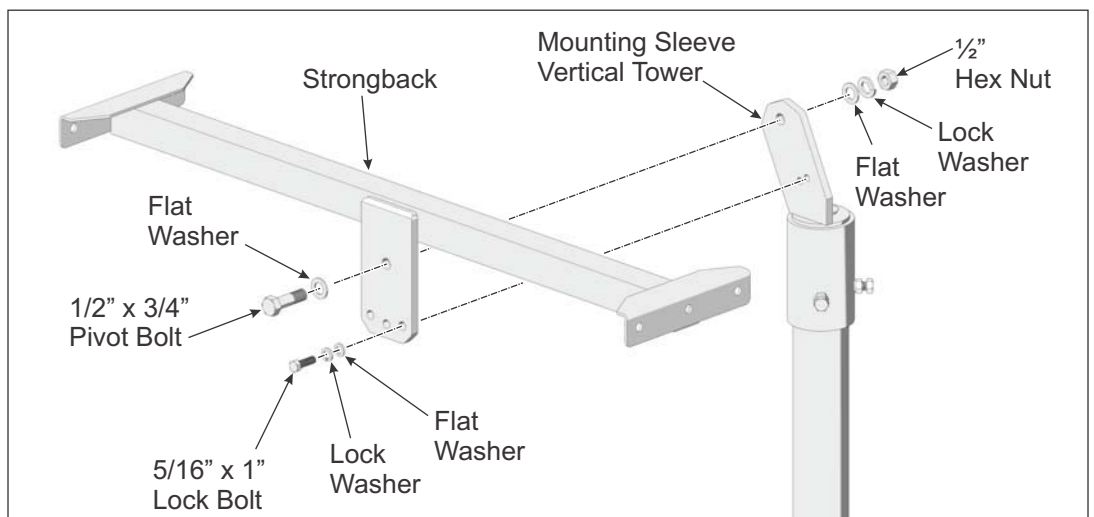

Figure 2-2: Installing the Strongback

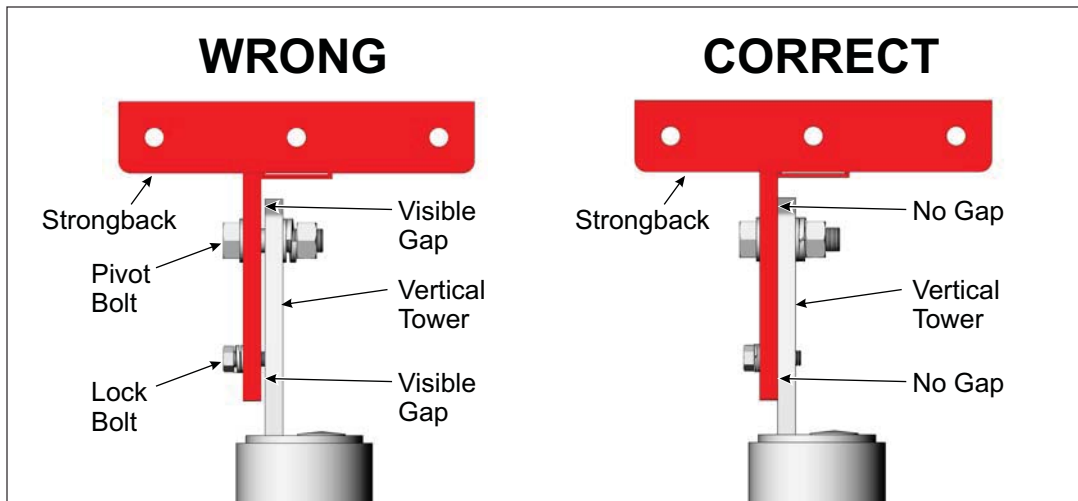

Figure 2-3: Tighten and Torque the Pivot Bolt

### Step 3: Attach the Module Rails to the Support Angles

Module Rails run in an E-W direction and are secured to the two Support Angles of the Strongback (these are welded to the Strongback) using 3/8" x 1" bolts and hardware. There are two Module Rails to install.

- A. Align the Module Rail mounting holes with the holes of the Support Angle and secure with 3/8" x 1" bolts and hardware. Finger-tighten for now. (See Figure 3-1)
- B. Continue in this manner and install the next Module Rail.

**CAUTION:**

This is a two person activity. Module Rails are unstable before they are fully secured to the Support Angles. Module Rails must be held in place by one person while the second person aligns and secures them to the Support Angles. Failure to do so could lead to serious personal injury.

**NOTE:**

Finger-tighten the Module Rails to the Support Angles while installing. After the Modules are installed, go back and tighten to specified torque values.

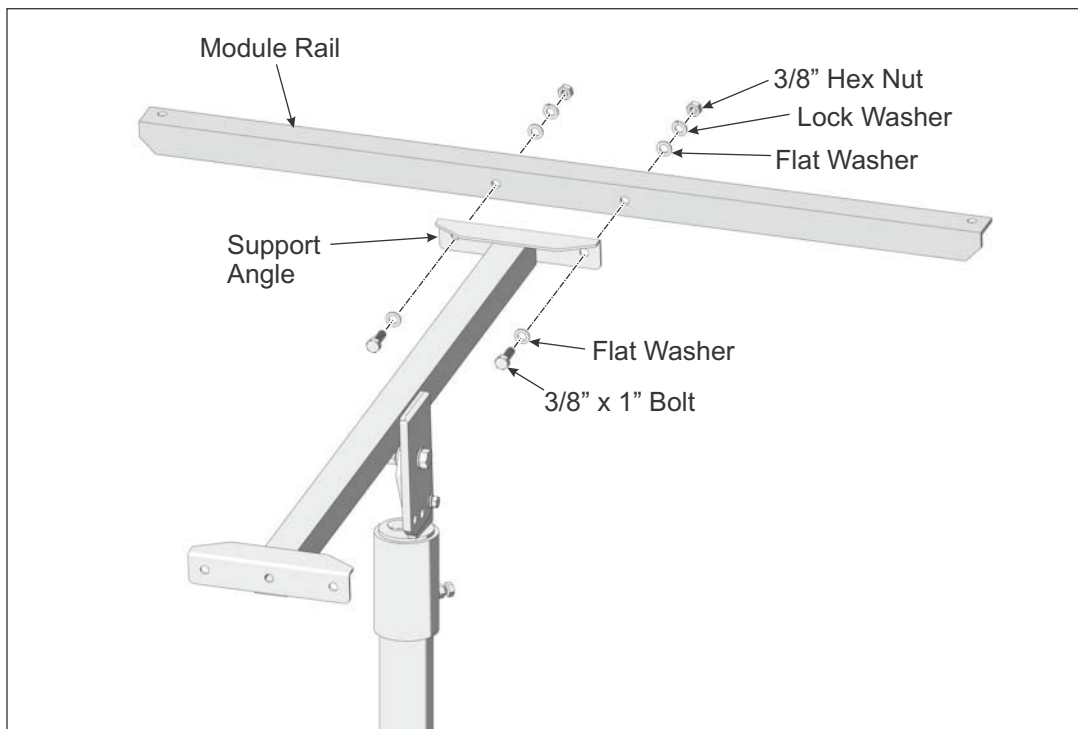

Figure 3-1: Attaching Module Rails

**CAUTION:**

This is a two person activity. PV Modules are heavy and unstable before they are fully secured to the Module Rails. PV Modules must be held in place by one person while the second person aligns and secures them to the Module Rails. Failure to do so could lead to serious personal injury and damaged components.

**Step 4: Installing PV Modules to Module Rails**

PV Modules are secured to the Module Rails using 1/4" x 3/4" bolts and hardware.

- A. Place the PV Module on the Module Rails. Align the mounting holes and secure with 1/4" x 3/4" bolts and hardware. Each Module has four attachment points. Finger-tighten for now. (See Figure 4-1)
- B. Continue in this manner and install the second PV Module.

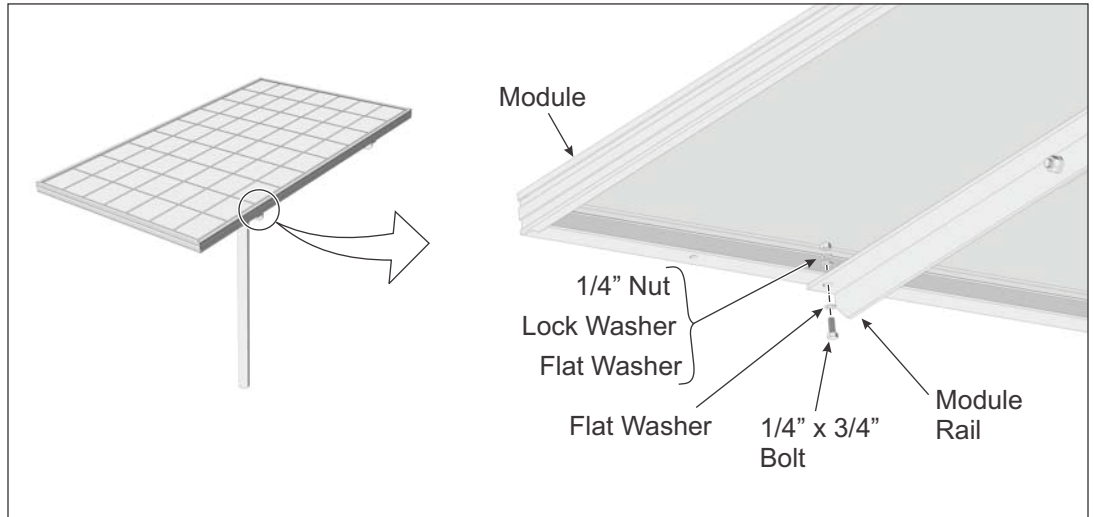

Figure 4-1: Installing PV Modules to Module Rails

**CAUTION:**

Be certain to go back and tighten all Module Rail and PV Module mounting hardware and torque to the specified values. Failure to do so could lead to structural failure, damaged components and/or serious personal injury.

**Step 5: Return and tighten mounting hardware.**

- A. Return and tighten each set of the 3/8" mounting hardware, securing the Module Rails to the Support Angles. **Torque all at 32-34 ft.-lbs.**
- B. Return and tighten each set of 1/4" mounting hardware, securing the PV Modules to the Module rails. **Torque all at 6-8 ft.-lbs.**

**Step 6: Adjust the Tilt Angle of the Rack**

Use great care as it can be dangerous if the procedure is not done as described and done with a minimum of two people. Adjust the tilt angle by loosening the Pivot Bolt hardware and removing the 5/16" x 1" Lock Bolt from the Strongback Pivot Plate.

- A. While one person holds the south edge of rack, the other loosens the Pivot Bolt and removes the 5/16" Lock Bolt from the Strongback Pivot Plate. (see Figure 6-1)
- B. Refer to Figure 6-2 and tilt the rack to the desired elevation angle (5°, 15°, 25°, 35°, 45°, or 55°). Re-insert the 5/16" Lock Bolt in the appropriate hole to match the desired elevation. **Torque to 12-14 ft.-lbs.**
- C. After changing the tilt angle and tightening the Lock Bolt, the Pivot Bolt must be re-tightened. The Pivot Bolt cannot be left loose - the Mounting Sleeve Vertical Tower must be firmly clamped to the Strongback Pivot Plate. **Torque Pivot Bolt to 75-85 ft.-lbs.** (see Figure 6-3)

**CAUTION:**

Do not attempt to remove the Pivot Bolt during tilt adjustments. Removal could lead to serious personal injury or death. Adjustments are made with the Pivot Bolt hardware loosened but in place.

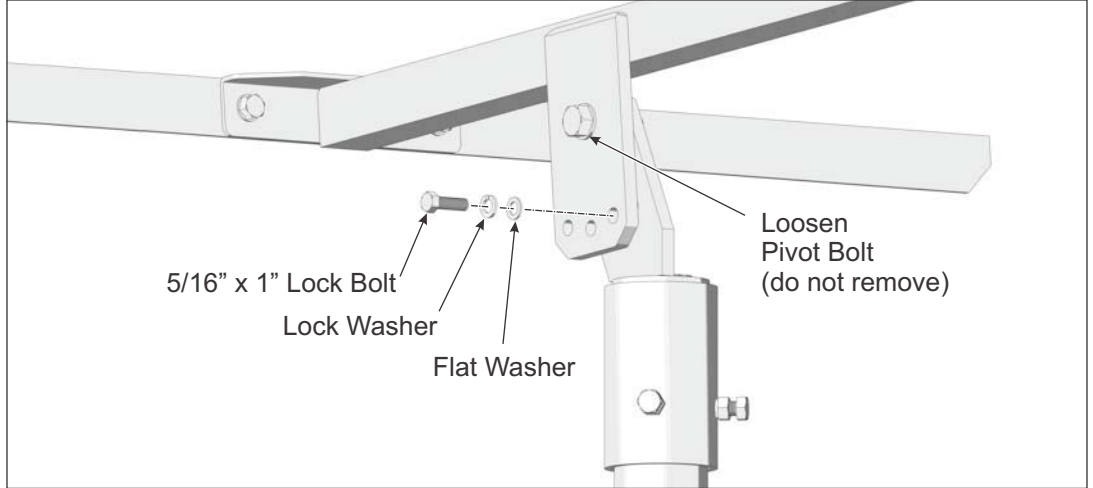

Figure 6-1: Preparing to Adjust the Tilt Angle

**CAUTION:**

This is a two person activity. As the Pivot Bolt is loosened and the 5/16" hardware is removed, the rack is heavy and unstable. It must be held in place by one person while the second person loosens and removes the hardware and then re-installs/tightens the hardware back in place. Failure to do so could lead to serious personal injury and damaged components.

Elevation Set Points		Lock Bolt Location	
		A	B
Lock Point	1	45°	55°
	2	25°	35°
	3	5°	15°

Figure 6-2: Setting the Elevation Angle

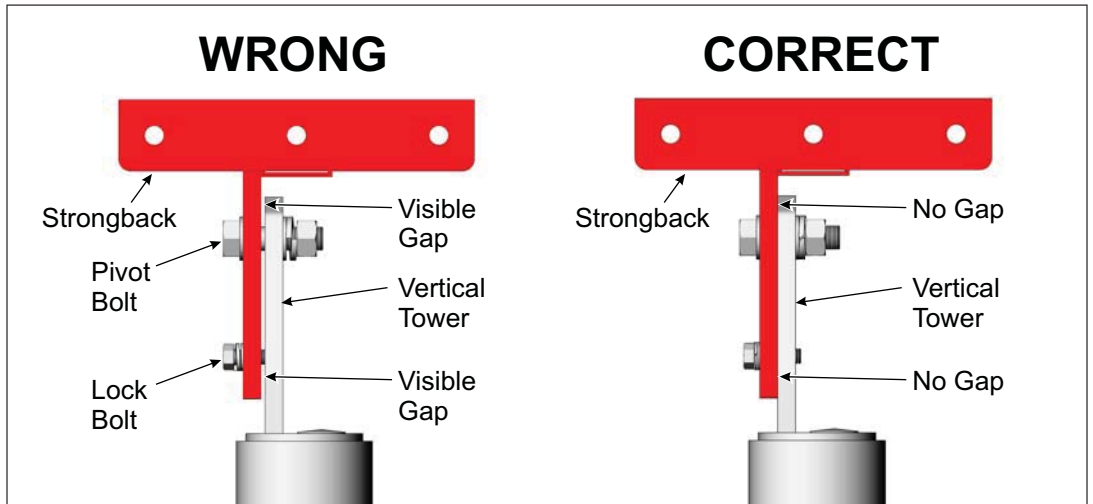

Figure 6-3: Re-Tighten and Torque the Pivot Bolt





---

Direct Power & Water Corporation  
4000-B Vassar Drive NE  
Albuquerque, New Mexico 87107  
USA

Telephone: 800.260.3792  
Fax: 505.889.3548  
Web Site: [www.DPWSolar.com](http://www.DPWSolar.com)  
E-mail: [info@power-fab.com](mailto:info@power-fab.com)

Preformed Line Products  
(Canada) Limited  
1711 Bishop St. E  
Cambridge, ON N1T 1N5

Telephone: 519.740.6666  
Fax: 519.740.7917  
Web Site: [www.preformed.on.ca](http://www.preformed.on.ca)  
E-mail: [sales@preformed.on.ca](mailto:sales@preformed.on.ca)