

Enphase Micro Inverter on a TPM Rack Installation Guidelines

This supplement covers how to attach an Enphase Microinverter (Inverter) to the Rails of a TPM (Top-of-Pole-Mount) rack. For detailed information on installing the Micro Inverter; including cabling etc., refer to relevant Enphase publications.

Attaching the Microinverter to the Rails

The Inverter attaches to the Rails using 5/16" hardware. Attach the Inverter to the Rail at the approximate centers of the PV Modules. (See Figure 1)

- A. Mark and then drill a 11/32" hole through the Rail where the Inverter will be attached. (See Figure 2)
- B. Attach the Inverter to the Rail and tighten securely. (See Figure 3)

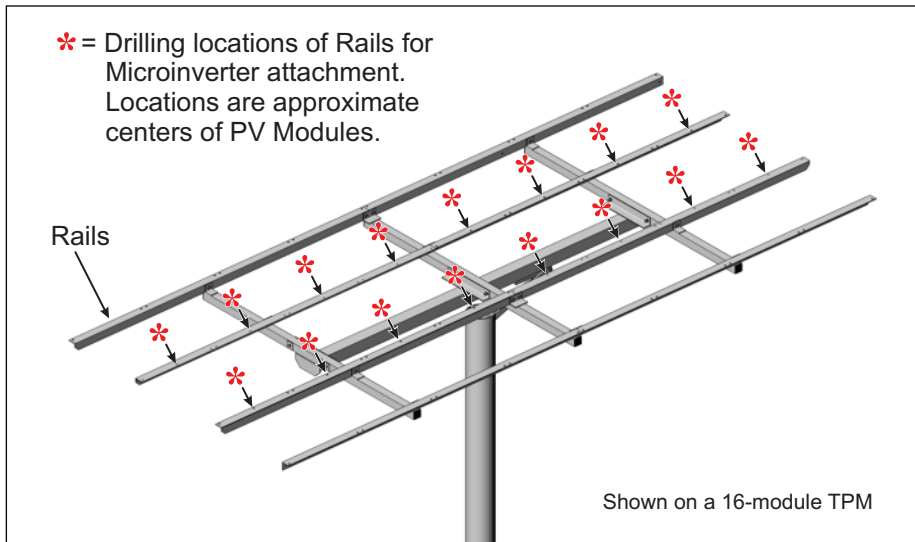

Figure 1: Rail Drilling Locations

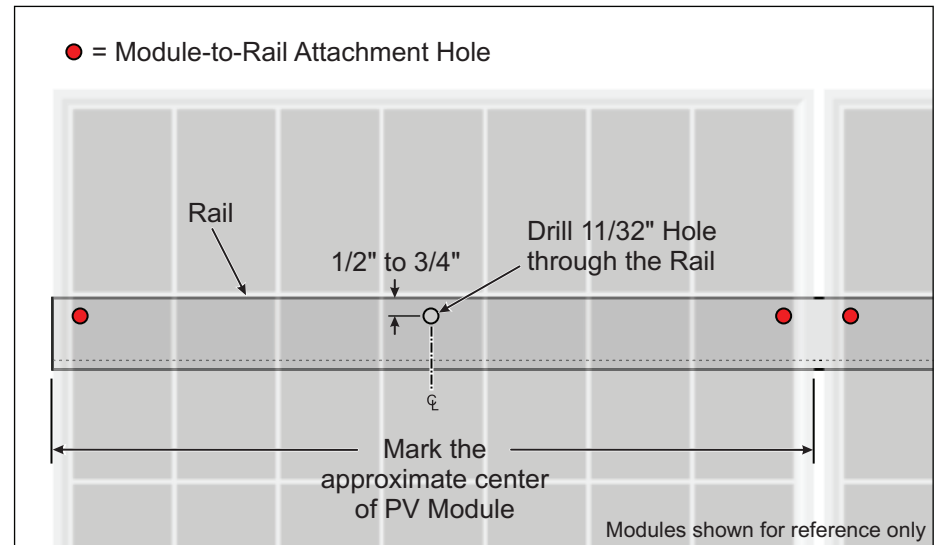

Figure 2: Measure, Mark, and Drill

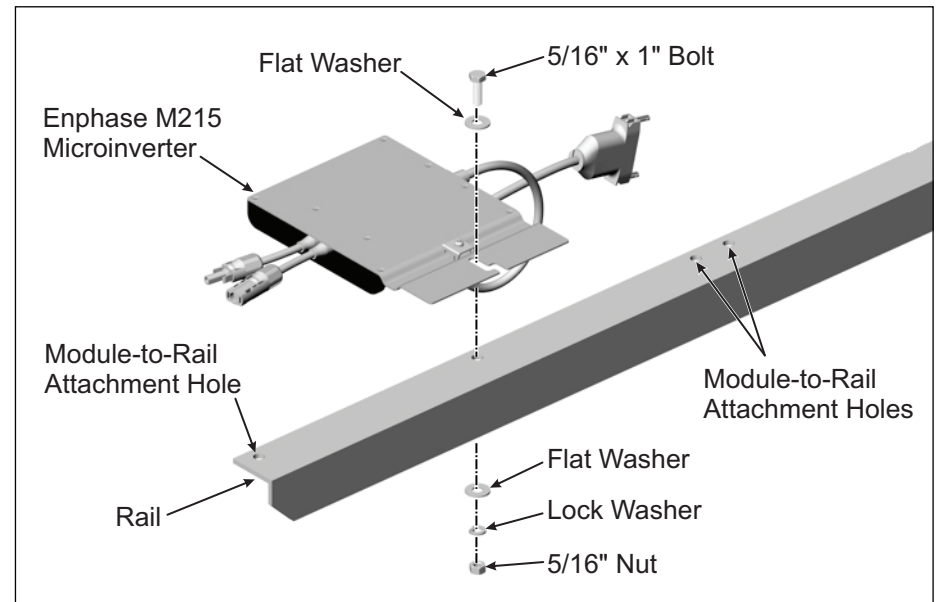

Figure 3: Attaching Microinverter to Rail