

Top Clamping Modules on TPM Rack Installation Supplement

This supplement shows how to attach PV Modules on a Top-of-Pole-Mount (TPM) rack using the top clamp method. It demonstrates the proper use of Mid Clamps and End Clamps along with the associated hardware.

Correctly Installing Mid and End Clamps

Mid and End clamps must be installed as shown. Failure to do so could lead to personal injury, structural failure and/or damaged components.

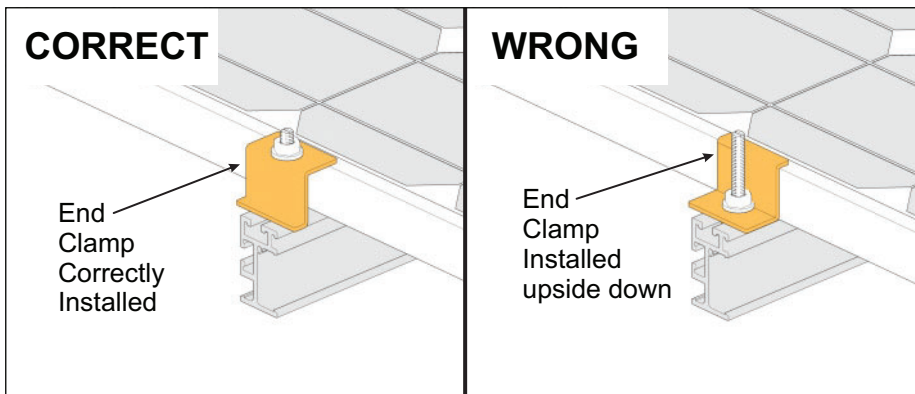
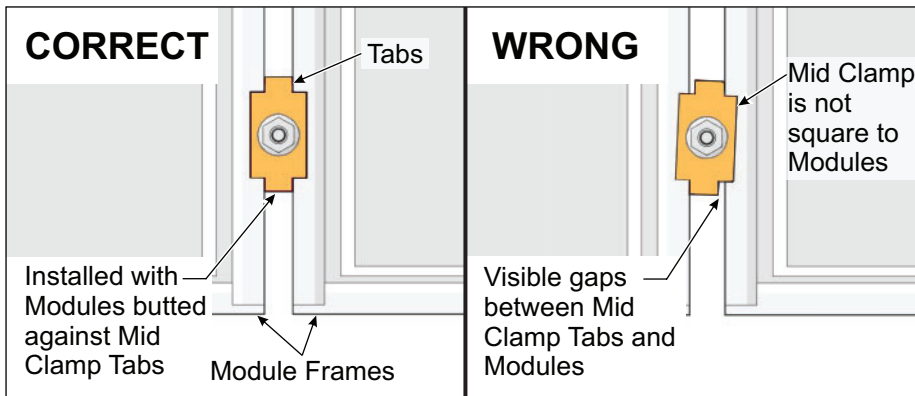

Installing Mid and End Clamps

Clamps are attached to the Rails using 5/16" RAD Bolts and Flange Nuts.

Mid Clamps

Mid Clamp tabs must rest between the Modules.

Parts:

- ① 5/16" Flange Nut
- ② Mid Clamp
- ③ 5/16" RAD Bolt (length depends on module thickness)

Torque: 14-16 ft.-lbs.

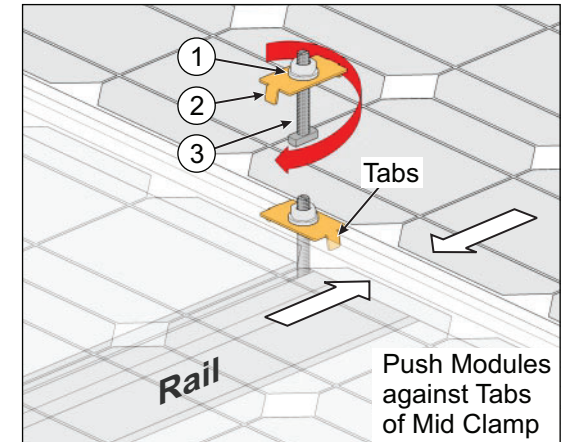

End Clamps

Make certain that End Clamps are installed as shown and not upside down.

Parts:

- ① 5/16" Flange Nut
- ② End Clamp
- ③ 5/16" x RAD Bolt (length depends on module thickness)

Torque: 14-16 ft.-lbs.

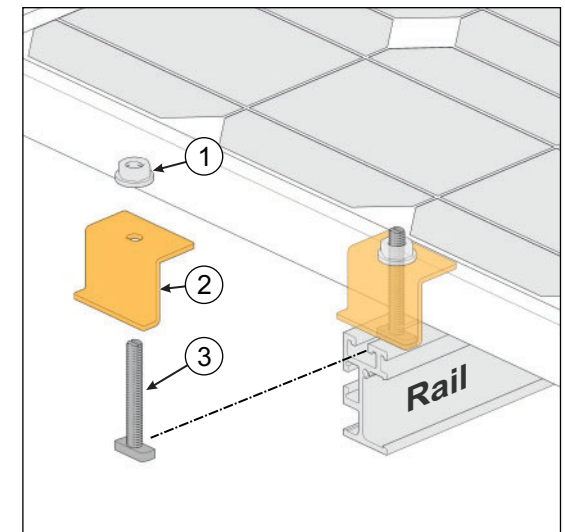



Albuquerque Office
1700 Louisiana Blvd., Suite 130
Albuquerque, NM 87110

Corporate Headquarters
660 Beta Drive
Mayfield Village, OH 44143

Telephone: 800.260.3792
Fax: 505.889.3548
www.preformed.com
E-mail: info@plpsolar.com

© 2017 Preformed Line Products
PCN 010617-1 Version 1, Rev B
SP3304-3