

**Headquarters**

545 Speedvale Avenue West, Guelph,
Ontario, Canada N1K 1E6
Tel: +1-519-837-1881 Fax: +1-519-837-2550
Email: inquire.ca@canadiansolar.com

Germany

Landsberger Strasse 94, 80339 Munich, Germany
Tel: +49 (0) 89-51 996 89-0
Fax: +49 (0) 89-51 996 89-11
Email: inquire.eu@canadiansolar.com

Italy

Via Vittoria Colonna 40, 00193 Rome, Italy
Tel: +39-06-6880-1085 Fax: +39-06-6830-0032
Email: inquire.it@canadiansolar.com

Spain

c/ Josefa Valcarcel, 8. 2nd floor, E-28027 Madrid, Spain
Tel: +34 91 320 28 84
Fax: +34 91 320 84 38
Email: Inquire.eu@canadiansolar.com

Australia

Unit 3B, North Rydelink Business Park 277-283 Lane Cove Road
Macquarie Park, NSW 2113, Australia
Tel: +61 (2) 9889 4395
Email: Inquire.au@canadiansolar.com

USA

12657 Alcosta Blvd, Suite 140, San Ramon, CA 94583
Tel: +1-925-866-2700 Fax: +1-925-866-2704
Email: inquire.us@canadiansolar.com

Japan

Round-Cross Shinjuku 5-Chome 8F, 5-17 Shinjuku Shinjuku-ku,
Tokyo Japan 160-0022
Tel: 03-5291-8591 Fax: 03-5291-8596
Email: inquire.jp@canadiansolar.com

Korea

201, SK HUB Officetel, 708-26, Yeoksam-Dong, Kangnam-gu,
Seoul, Korea
Tel: (02) 539-7541 Fax: (02) 539-7505
Email: inquire.kr@canadiansolar.com

Singapore

101 Thomson Road, #15-03 United Square
Singapore 307591
Tel: +65 65729050 Fax: +65 62594690

China

199 Lushan Road, Suzhou New District, Jiangsu, China, 215129
Tel: +86 (512) 6690-8088
Email: inquire@canadiansolar.com

www.canadiansolar.com



Solar Module Installation Manual (UL)



www.canadiansolar.com

1.0 GENERAL INFORMATION

This general manual provides important safety information relating to the installation, maintenance and handling of CS-series solar modules. System users and professional installers should read this manual carefully and strictly follow the instructions. Failure to follow these instructions may result in death, injury or property damage. The installation of solar modules requires specialized skills and should only be performed by licensed professionals. The word "module" or "PV module" used in this manual refers to one or more CS-Series Solar Modules. Please retain this manual for future reference. It is recommended to regularly check online for the most updated version.

1.1 DISCLAIMER OF INSTALLATION MANUAL

The information contained in this manual is subject to change by Canadian Solar Inc. without prior notice. Canadian Solar Inc. makes no warranty of any kind whatsoever, either explicitly or implicitly, with respect to the information contained herein.

1.2 LIMITATION OF LIABILITY

Canadian Solar Inc. shall not be held responsible for damages of any kind, including without limitation bodily harm, injury and property damage, relating to module handling, system installation, or compliance or non-compliance with the instructions set forth in this manual.

2.0 SAFETY PRECAUTIONS



Warning: All instructions should be read and understood before attempting to install, wire, operate and/or maintain the module. Module interconnects pass direct current (DC) when exposed to sunlight or other light sources. Contact with electrically active parts of the module, such as terminals, can result in injury or death, whether the module is connected or disconnected.



Avertissement: Toutes les instructions devront être lues et comprises avant de procéder à l'installation, le câblage, l'exploitation et/ou l'entretien des panneaux. Les interconnexions des panneaux conduisent du courant continu (CC) lorsque le panneau est exposé à la lumière du soleil ou à d'autres sources lumineuses. Tout contact avec des éléments sous tension du panneau tels que ses bornes de sortie peut entraîner des blessures ou la mort, que le panneau soit connecté ou non.

General Safety

- All installations must be performed in compliance with all applicable regional and local codes such as, the latest National Electrical Code (USA) or Canadian Electric Code (Canada) or other national or international electrical standards.
- Wear suitable protection (non-slip gloves, clothes, etc.) to prevent direct contact with 30VDC or greater, and to protect your hands from sharp edges during the installation.
- Use electrical insulated tools to reduce the risk of electric shock.
- Remove all metallic jewelry prior to installation to reduce the chance of accidental exposure to live circuits.
- Cover the front of the modules in the PV array with an opaque material to halt production of electricity when installing or working with a module or wiring.
- Do not install or handle the modules when they are wet or during periods of high wind.
- Do not use or install broken modules.
- If the front glass is broken, or the back sheet is torn, contact with any module surface or the frame can cause electric shock.
- Keep the junction box cover closed at all times.
- Do not attempt to repair any part of the module. There're no serviceable parts within the PV module.
- Do not disassemble a module or remove any module part.
- Do not artificially concentrate sunlight on a module.
- Do not connect or disconnect modules when current from the modules or an external source is present.

3.0 MECHANICAL / ELECTRICAL SPECIFICATIONS

The module electrical ratings are measured under Standard Test Conditions (STC) of 1 kW/m² irradiance with an AM1.5 spectrum, and cell temperature of 25°C. The detailed electrical and mechanical characteristics of Canadian Solar Inc. crystalline silicon PV modules can be found in table A-2 of this manual (see Annex). Main electrical characteristics at STC also appear on each module label. The maximum system voltage for all module series is 600 V. Under certain conditions, a module may produce more current or voltage than its Standard Test Conditions (STC) rated power. Accordingly, a module's open-circuit voltage and short-circuit current at STC should be multiplied by 1.25 when determining component ratings and capacities. An additional 1.25 multiplier for a short-circuit current (for a total of 1.56), for sizing conductors and fuses may be applicable, as described in section 690-8 of U.S. NEC.

3.1 DIODES

- Diodes inside the junction box should meet requirements below:

Table 3-1: By-pass diode specifications

Module series	Number of bypass diodes	Number of cells by diodes	Diode ratings		Diode type
			Voltage	Current	
CS6P-PE	5	12	≥40V	≥12 A	Schottky diodes
CS6A-PE	5	10 (for 3 substrings) 9 (for 2 substrings)			
CS5P	4	24		≥10A	
CS5A	3	24			
CS5T		20			
CS6A		16			
CS6P		20			
CS6X		24			
CS6H		2		18	
CS5C	18				
CS6E	18				
CS6D	18				
CS6C	18				
CS5E	18				
CS5H	18	≥10A			

- Diode configurations as below:

CS5P

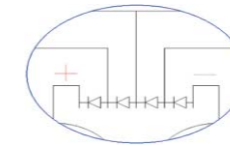

CS6P-PE
/CS6A-PE

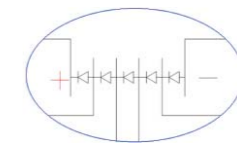

CS5A/CS5T
/CS6A/CS6P
/CS6X

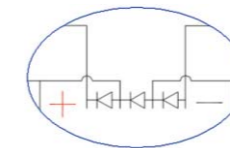

CS6H/CS5C
/CS6E/CS6D
/CS6C/CS5E
/CS5H

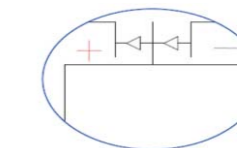

4.0 UNPACKING AND STORAGE



Precautions and General Safety

- Store modules in a dry and ventilated room .
- Do not allow children and unauthorized persons near the installation site or storage area of modules.
- Do not transport modules in an upright position.
- Unpacking module pallet with care and follow the unpacking steps marked on the pallet. Be careful when unpacking, transporting and storing the modules.
- Do not carry a module by its wires or junction box. Carry a module by its frame with two or more people.
- Do not place modules on top of each other.
- Do not place excessive loads on the module or twist the module frame.
- Do not bow modules under their own weight.
- Do not stand, step, walk and/or jump on the module.
- Do not drop or place objects on the modules (such as tools.)
- Do not mark the modules with sharp instrument. Particular attention should be taken to avoid module backsheet to come in contact with sharp objects, as scratches may directly affect product safety.
- Do not leave a module unsupported or unsecured.
- Do not change the wiring of bypass diodes.
- Keep all electrical contacts clean and dry.

5.0 MODULE INSTALLATION



Precautions and General Safety

- Before installing modules, contact the appropriate authorities for site, installation and inspection permission and requirement.
- Check applicable building codes to ensure that the construction or structure (roof, facade, support, etc.) can withstand the module system load.
- When installing the modules, please ensure the assembly is mounted over a fire resistant roof covering rated for the application. Canadian Solar modules have been listed as Class C according to UL790 standard.
- CAUTION: In any case DO NOT STAND OR STEP on the modules, as localized high loads may induce severe micro-cracks at the cell level, which in turn may compromise module reliability. Failure to comply with above caution will void Canadian Solar Inc warranty.



NO TRAMPLING

Environmental conditions

- The module is intended for use in general open climates, as defined in IEC 60721-2-1: Classification of environmental conditions Part 2-1: Environmental conditions appearing in nature - temperature and humidity.
- Do not install modules near naked flames or flammable materials.
- Do not expose modules to artificially concentrated light sources.
- Do not immerse modules in water or constantly expose modules to water (either fresh or salt) (i.e. from fountains, sea spray).
- Exposing modules to salt (i.e. marine environments) and sulfur (i.e. sulfur sources, volcanoes) risks module corrosion.

Requirements of installation

- Ensure that the module meets the technical requirements of the system as a whole.
- Ensure that other systems components do not exert damaging mechanical or electrical influences on the modules.
- Modules can be wired in a series to increase voltage or in parallel to increase current. To connect in series, connect cables from the positive terminal of one module to the negative terminal of the next module. To connect in parallel, connect cables from the positive terminal of one module to the positive terminal on the next module.
- Quantity of bypass diodes provided can vary depending on model series.
- Connect the quantity of modules that match the voltage specifications of the inverters used in the system. Modules must NOT be connected together to create a voltage higher than the permitted maximum system voltage, even under the worst local temperature conditions.
- Similar electrical performance modules should be connected in the same series to avoid or minimize mismatch effects in arrays.
- To minimize risk in the event of an indirect lightning strike, avoid forming loops when designing the system.
- The recommended maximum series fuse rating is tabulated in annex.
- Modules should be firmly fixed in place in a manner suitable to withstand all expected loads, including wind and snow loads. A minimum clearance of 6.5 mm (1/4 of an inch) or more between modules is required to allow for thermal expansion of the frames.
- Small openings for water draining on the underside of the module should not be blocked after mounting.

Optimum orientation and tilt

- Find out the optimum orientation and tilt of the PV modules for your region to achieve the maximum annual yield. Generation of maximum power occurs when sunlight shines perpendicularly onto the PV modules.

Avoid shading

- Even the slightest partial shading (e.g., from dirt deposits) will cause a reduction in yield. A module is considered "shadow-free" if it is unobstructed across its entire surface for the whole year. Even on the shortest day of the year, unobstructed sunlight can reach the module.

Reliable ventilation

- Sufficient clearance (at least 10 cm) between the module frame and the mounting surface is required to allow for cooling air to circulate around the back of the module. This also allows for condensation or moisture to dissipate.

5.1 MODULE WIRING

Correct wiring scheme

- When designing the system, avoid forming loops (to minimize risk in the event of an indirect lighting strike). Make sure that wiring is correct before starting up the system. If the measured open circuit voltage (Voc) and short-circuit current (Isc) differ from the specifications, then there is a wiring fault.

Correct connection of plug connectors

- Make sure that the connection is safe and tight. The plug connector should not receive outer stress. The connector should only be used to connect the circuit. It should never be used to turn the circuit on and off.

Use of suitable materials

- Use special solar cable and suitable plugs only (wiring should be placed in conduit that is sunlight-resistant or, if exposed, should be sunlight-resistant) in accordance with local fire, building and electrical code. Ensure that they are in perfect electrical and mechanical condition.
- The permitted type of solar cable is single conductor cable listed and labeled as USE-2 or PV Wire, 90°C wet rated, with proper insulation to withstand the maximum possible system open-circuit voltage. The conductor material should use copper only. Select a suitable conductor gauge to minimize voltage drop and ensure conductor ampacity complies with local regulations (such as NEC 690.8(D)).

Cable protection

- Secure the cables to the mounting system using UV-resistant cable ties. Protect exposed cables from damage with appropriate precautions (e.g. locate them within plastic conduit). Avoid exposure to the direct sunlight.

5.2 GROUNDING

- Although the modules are certified to safety class II, it is required that they be grounded. And the module installation complies with all local electrical codes and regulations.
- The earth grounding connection should be made by a qualified electrician.
- Connect module frames to each other using suitable grounding conductor. Holes provided for this purpose are identified with a green label.
- Use 6-12 AWG (4-14 mm²) copper wire only. The bolts, nuts, flat washers, lock washers or other relevant hardware should be made of stainless steel, unless otherwise specified.
- All the junctions on the conductive connection must be fixed. Metal containing iron in the conductive connection should be made with stainless steel or be treated against corrosion by anodizing, spray-painting, or galvanization to prevent rusting and corrosion.
- Grounding hardware is not provided by Canadian Solar Inc.
- One grounding method approved by North-American certification bodies (CSA, and Intertek) is recommended for Canadian Solar modules, as described below. For alternative CSA and Intertek qualified grounding methods, please refer to Annex B.

Method B: Bolt + Nut with teeth + Cup washer

When diameter of the grounding holes is 5mm (CSA certified).

- A grounding kit with M5 size SS cap bolt, M5 size SS flat washer, M5 size SS cup washer, and M5 size SS nut (with teeth) is used to attach a copper grounding wire to grounding hole pre-drilled on the frame (see picture below).
- Attach the wire between the flat washer and the cup washer. Ensure the cup washer is between the frame and wire with concave side up to prevent corrosion due to dissimilar metal. Tighten the bolt securely using the SS nut with teeth. A wrench may be used in this application. The tightening torque is 1 Nm.



Attach wire between the flat washer and cup washer. Place cup washer (concave side up) between frame and wire.

Tighten the bolt using the nut with teeth.

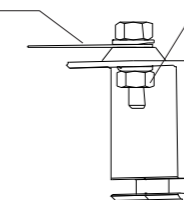

6.0 MOUNTING INSTRUCTIONS

Standard modules

- For a clear understanding of module, please refer to the illustration of a standard module shown below:

Reference	Designation
1	Grounding holes
2	Junction box
3	Standard mounting holes (long side)
4	Additional mounting holes (high wind or snow loads)
5	Standard mounting holes (short side)
6	Module frame
7	Cables and connectors

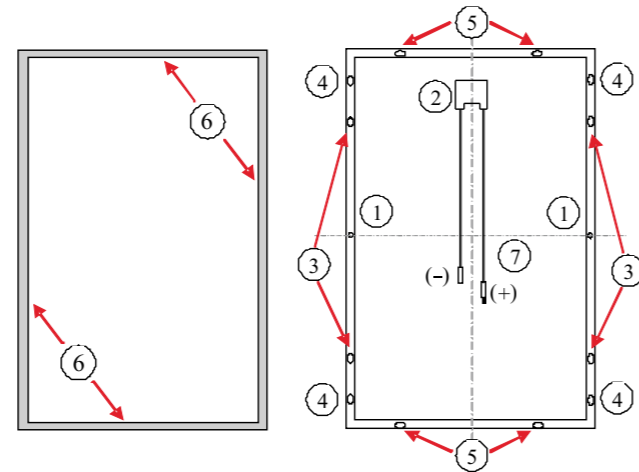

- The mounting design must be certified by a registered professional engineer. The mounting design and procedures shall comply with local electrical and building codes.
- Mounting hardware is not provided by Canadian Solar Inc.
- Canadian Solar Inc. modules can be mounted to a support structure by several approved methods, either using the mounting holes located on the back frame (see Example A), or by means of clamps (see Example B). For other installation hardware, please contact your local representative for further information. Failure to use a recognized installation method will void Canadian Solar Inc warranty.
- Only the bolting method has been qualified by North-American certification bodies (CSA, and Intertek) during testing and listing of Canadian Solar modules according to UL1703 standard. For inlay-systems or other installation hardware, please contact your local representative for further information. Alternative mounting methods qualified internally by Canadian Solar Inc. are described in Annex C.

Example A:
Bolting (INTERTEK and CSA qualified)



Example B:
Clamping on (INTERTEK qualified)

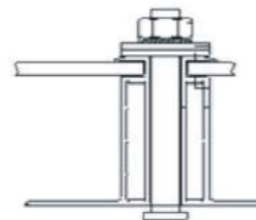

- Use appropriate corrosion-proof fastening materials. All mounting hardware (bolt/spring washer/flat washer/nut) should be made with stainless steel M6 size for bolting method (A), and M8 size for clamping method (B).
- Use a torque wrench for installation. The above figure shows methods of fastening module to support structure. Tightening torques should respectively be within 4~6 Nm and 10~17 Nm for M6x1 (Example A) and M8x1.5 (Example B) coarse thread bolts, depending on bolt class. Different recommendations from specific clamping hardware suppliers should prevail.
- Canadian Solar Inc. modules can be installed in either landscape or portrait position, refer to the detailed instructions (see table 6-1) for further guidance. Note that further countermeasures such the use of additional support bars should be considered in heavy snow areas (> 2400 Pa), to avoid damage by the snow accumulating in the lowest row of modules.
- When the addition of a support bar is recommended to enhance mechanical stability and module long term performance reliability, material of suitable resistance should be selected. Canadian Solar Inc recommends a minimum thickness of 50mm for the bar. The support bar centerline should be positioned within 100 mm of the side frame centerline (slight shift may be necessary to access module grounding hole).

6.1 MOUNTING METHOD: BOLTING

- Modules should be bolted to support structures through mounting holes located in the frame's back flanges only. Do not drill additional holes or modify the module frame. Doing so will void the warranty.
- Each module must be securely fastened at a minimum of 4 points on two opposite sides, using the most inner mounting holes. If additional wind loads are anticipated for this installation, additional mounting points should be used. System designer and installer are responsible for load calculations and for proper support structure design.
- Modules should be bolted at the following hole locations depending on the configuration and load:

Table 6-1: Authorized attachments for bolting method

	Uplift load ≤ 2400 Pa Downforce load ≤ 2400 Pa	Uplift load ≤ 2400 Pa 2400 Pa ≤ Downforce load ≤ 5400 Pa
Bolting on short side frame (except for 6X series)	Use 4 standard mounting holes (short side) Mounting rails may run parallel or perpendicularly to the short side frame	Use 4 standard mounting holes (short side). An additional support bar should be placed below the module. Mounting rails should run parallel to the short side frame
Bolting on long side frame	Use 4 standard mounting holes (long side) Mounting rails may run perpendicularly or parallel to the long side frame	

6.2 SPECIFIC MODULE RANGES

Technical notes

- For NewEdge module frames (NewEdge series: CS5A-xxxMX, CS6A-xxxPX and CS6P-xxxPX models), please refer to the most updated IM/NEWE-EN technical note (INTERTEK & CSA certified).
- For CS5A-M-L laminate models only, floating clamped configuration should be used. Please refer to the most updated IM/LAM-EN technical note (CSA certified)

7.0 MAINTENANCE

- Regular maintenance is required to keep modules clear of snow, bird droppings, seeds, pollen, leaves, branches, dirt spots and dust.
- If a module has a sufficient tilt (at least 15°), it generally is not necessary to clean the modules (rainfall will have a self-cleaning effect). When there is a noticeable buildup of soiling deposits on the module surface, wash the PV array with water and a gentle cleaning implement (a sponge) during the cool part of the day. Dirt must never be scraped or rubbed away when dry, as this will cause micro-scratches.
- If snow is present, a brush with soft bristles can be used to clean the surface of the module.
- Periodically inspect the system to make sure all wiring and supports stay intact.
- If you need electrical or mechanical inspection or maintenance, it is recommended to have a licensed, authorized professional carry out the job to avoid hazards of electric shock or injury.
- Do not change the PV components (diode, junction box, plug connectors).

ANNEX A: MECHANICAL AND ELECTRICAL RATINGS

Standard Test Conditions are: irradiance of 1 kW/m², AM1.5 spectrum, and cell temperature of 25°C (77°F). The electrical characteristics are respectively within ± 10 percent or [0, +5W] of the indicated values for I_{sc}, V_{oc} and P_{max}. Specifications are subject to change without notice.

Table A-1: Certification map for CS-series photovoltaic modules

Certification Body	CS5A-M CS5A-MX	CS5A-P	CS5P-M	CS5P-P	CS5T-M	CS5E-M, CS5H-M, CS5C-M, CS5C-P	CS5A-M-L	CS6X-P	CS6X-M
Intertek	150-190W (CS5A-M only)	150-190W	200-260W	200-240W					
CSA	170-200W	165-195W		215-260W	130-150W	CS5E: 20-25W CS5H: 43-50W CS5C-M: 85-100W CS5C-P: 80-95W	170-200W	250-310W	260-310W
Certification Body	CS6P-M CS6P-MX	CS6P-PM CS6P-MM	CS6P-P CS6P-PX	CS6P-PE	CS6H, CS6E, CS6D, CS6C (-M/P)	CS6A-M	CS6A-P, CS6A-PE	CS6A-PM, CS6A-MM	CS6A-PX
Intertek	160-230W (CS6P-M only)		160-230W (CS6P-P only)	160-230W		160-190W	135-190W		
CSA	200-260W	225-270W	200-260W		CS6H: 20-26W CS6E: 45-60W CS6D: 60-75W CS6C: 120-145W			CS6A-PM: 175-220W CS6A-MM: 180-220W	160-210W

Table A-2: Specifications for CS-series photovoltaic modules under STC

Model Type	Maximum power P _{max} <W>	Operating Voltage (V _{mp}) <V>	Operating current I _{mp} <A>	Open Circuit Voltage V _{oc} <V>	Short Circuit Current I _{sc} <A>	Max. Series Fuse Rating <A>	Overall Dimension <mm>	Weight <Kg>
CS5E-20M	20	17.6	1.14	21.9	1.23	3.00	620x284x25	2.10
CS5E-22M	22	17.9	1.23	22.2	1.31			
CS5E-24M	24	18.4	1.31	22.4	1.41			
CS5E-25M	25	18.7	1.34	22.6	1.43			
CS5H-43M	43	17.8	2.41	22.2	2.57	5.00	630x542x25	3.5
CS5H-45M	45	18	2.5	22.3	2.67			
CS5H-47M	47	18.3	2.57	22.4	2.75			
CS5H-50M	50	18.7	2.68	22.6	2.86			
CS5C-85M	85	17.8	4.78	22.1	5.12	10.00	1213x547x35	8.00
CS5C-90M	90	18	4.99	22.3	5.34			
CS5C-95M	95	18.3	5.19	22.4	5.52			
CS5C-100M	100	18.5	5.39	22.5	5.74			
CS5A-150M	150.0	35.0	4.29	43.3	4.69	10.00	1595X801X40 (standard Ed1) or 1580 X808X40 (standard Ed2) or 1589X795X22.5 (M-L only)	15.30 (standard) or 17.00 (MX only) or 15.5kg (M-L only)
CS5A-155M	155.0	35.1	4.42	43.6	4.80			
CS5A-160M	160.0	35.1	4.55	43.8	4.91			
CS5A-165M	165.0	35.3	4.68	44.1	5.01			
CS5A-170M/MX/M-L	170.0	35.6	4.78	44.3	5.12			
CS5A-175M/MX/M-L	175.0	35.8	4.89	44.4	5.23			
CS5A-180M/MX/M-L	180.0	36.1	4.99	44.6	5.34			
CS5A-185M/MX/M-L	185.0	36.4	5.09	44.6	5.46			
CS5A-190M/MX/M-L	190.0	36.6	5.19	44.8	5.52			
CS5A-195M/MX/M-L	195.0	37	5.27	45	5.62			
CS5A-200M/MX/M-L	200.0	37.4	5.35	45.3	5.71			
CS5A-150P	150.0	34.6	4.33	43.0	4.76	10.00	1595X801X40 (standard Ed1) or 1580 X808X40 (standard Ed2)	15.30
CS5A-160P	160.0	34.8	4.60	43.4	4.99			
CS5A-165P	165.0	34.9	4.73	43.7	5.09			
CS5A-170P	170.0	35.2	4.83	43.9	5.20			
CS5A-175P	175.0	35.4	4.94	44.1	5.31			
CS5A-180P	180.0	35.7	5.04	44.2	5.41			
CS5A-190P	190.0	36.2	5.25	44.4	5.61			
CS5A-195P	195.0	36.6	5.32	44.6	5.70			

Model Type	Maximum power P _{max} <W>	Operating Voltage (V _{mp}) <V>	Operating current I _{mp} <A>	Open Circuit Voltage V _{oc} <V>	Short Circuit Current I _{sc} <A>	Max. Series Fuse Rating <A>	Overall Dimension <mm>	Weight <Kg>			
CS5P-200M	200.0	46.7	4.29	57.8	4.69	10.00	1602X1061X40	20.30			
CS5P-205M	205.0	46.7	4.39	58.0	4.77						
CS5P-210M	210.0	46.8	4.49	58.2	4.86						
CS5P-215M	215.0	46.8	4.59	58.4	4.95						
CS5P-220M	220.0	47.0	4.68	58.8	5.01						
CS5P-225M	225.0	47.4	4.74	59.0	5.09						
CS5P-230M	230.0	47.5	4.84	59.1	5.18						
CS5P-235M	235.0	47.7	4.93	59.2	5.27						
CS5P-240M	240.0	48.1	4.99	59.4	5.34						
CS5P-245M	245.0	48.4	5.06	59.5	5.43						
CS5P-250M	250.0	48.7	5.14	59.6	5.49						
CS5P-255M	255.0	49.0	5.21	59.8	5.55						
CS5P-260M	260.0	49.3	5.27	60.0	5.62						
CS5P-200P	200.0	46.2	4.33	57.3	4.76				10.00	1602X1061X40	20.30
CS5P-205P	205.0	46.2	4.43	57.5	4.85						
CS5P-210P	210.0	46.3	4.53	57.7	4.93						
CS5P-215P	215.0	46.4	4.64	57.9	4.99						
CS5P-220P	220.0	46.6	4.73	58.3	5.05						
CS5P-225P	225.0	46.9	4.79	58.6	5.13						
CS5P-230P	230.0	47.0	4.89	58.7	5.22						
CS5P-235P	235.0	47.2	4.98	58.8	5.31						
CS5P-240P	240.0	47.6	5.04	58.9	5.38						
CS5P-245P	245.0	47.9	5.11	59.0	5.47						
CS5P-250P	250.0	48.2	5.19	59.1	5.53						
CS5P-255P	255.0	48.5	5.26	59.3	5.58						
CS5P-260P	260.0	48.9	5.32	59.5	5.63						
CS5T-130M	130.0	29.2	4.45	36.3	4.82	10.00	1638x982x40	19.00			
CS5T-135M	135.0	29.3	4.60	36.6	4.95						
CS5T-140M	140.0	29.5	4.74	36.8	5.08						
CS5T-145M	145.0	29.8	4.87	37.0	5.21						
CS5T-150M	150.0	30.1	4.99	37.1	5.34	3.00	534x350x25	2.40			
CS6H-20M	20.0	17.5	1.14	21.9	1.26						
CS6H-22M	22.0	17.7	1.24	22.1	1.33						
CS6H-24M	24.0	18.1	1.33	22.4	1.41						
CS6H-26M	26.0	18.4	1.41	22.7	1.50						
CS6H-20P	20.0	17.3	1.16	21.7	1.28				3.00	534x350x25	2.40
CS6H-22P	22.0	17.5	1.25	21.9	1.35						
CS6H-24P	24.0	17.9	1.34	22.2	1.43						
CS6H-26P	26.0	18.2	1.43	22.5	1.52						
CS6E-45M	45.0	17.5	2.57	21.9	2.83				5.00	608x666x35	5.10
CS6E-50M	50.0	17.8	2.82	22.2	3.00						
CS6E-55M	55.0	18.2	3.03	22.4	3.22						
CS6E-60M	60.0	18.6	3.23	22.8	3.42						
CS6E-45P	45.0	17.3	2.60	21.7	2.88	5.00	608x666x35	5.10			
CS6E-50P	50.0	17.6	2.84	22.0	3.05						
CS6E-55P	55.0	18.0	3.06	22.2	3.27						
CS6E-60P	60.0	18.4	3.26	22.6	3.47						
CS6D-60M	60.0	17.5	3.43	21.9	3.78	10.00	783x666x35	6.50			
CS6D-65M	65.0	17.6	3.68	22.1	3.96						
CS6D-70M	70.0	18.0	3.89	22.3	4.15						
CS6D-75M	75.0	18.3	4.11	22.5	4.37						
CS6D-60P	60.0	17.3	3.47	21.7	3.84	10.00	783x666x35	6.50			
CS6D-65P	65.0	17.5	3.72	21.9	4.02						
CS6D-70P	70.0	17.8	3.93	22.1	4.21						
CS6D-75P	75.0	18.1	4.15	22.3	4.43						

Model Type	Maximum power Pmax<W>	Operating Voltage (Vmp) <V>	Operating current Imp <A>	Open Circuit Voltage Voc <V>	Short Circuit Current Isc <A>	Max. Series Fuse Rating <A>	Overall Dimension <mm>	Weight <Kg>			
CS6C-120M	120.0	17.5	6.86	21.9	7.56	15.00	1485x666x40	12.00			
CS6C-125M	125.0	17.6	7.12	22.0	7.71						
CS6C-130M	130.0	17.6	7.38	22.1	7.95						
CS6C-135M	135.0	17.8	7.58	22.2	8.07						
CS6C-140M	140.0	18.0	7.76	22.3	8.28						
CS6C-145M	145.0	18.1	8.01	22.4	8.52						
CS6C-120P	120.0	17.3	6.93	21.7	7.67	15.00	1485x666x40	12.00			
CS6C-125P	125.0	17.4	7.19	21.8	7.83						
CS6C-130P	130.0	17.4	7.46	21.9	8.07						
CS6C-135P	135.0	17.6	7.65	22.0	8.19						
CS6C-140P	140.0	17.9	7.84	22.1	8.40						
CS6C-145P	145.0	17.9	8.09	22.2	8.65						
CS6P-160M	160.0	27.9	5.74	35.8	6.46	15.00	1638X982X40	19.00 (Standard) or 19.50 (MM Only)			
CS6P-165M	165.0	28.0	5.90	35.9	6.62						
CS6P-170M	170.0	28.3	6.01	36.0	6.74						
CS6P-175M	175.0	28.5	6.15	36.1	6.89						
CS6P-180M	180.0	28.5	6.31	36.1	7.05						
CS6P-185M	185.0	28.8	6.42	36.2	7.16						
CS6P-190M	190.0	28.9	6.57	36.3	7.31						
CS6P-195M	195.0	29.0	6.73	36.4	7.43						
CS6P-200M	200.0	29.2	6.86	36.5	7.56						
CS6P-205M	205.0	29.2	7.02	36.5	7.66						
CS6P-210M	210.0	29.3	7.17	36.7	7.77						
CS6P-215M	215.0	29.3	7.33	36.8	7.89						
CS6P-220M	220.0	29.5	7.45	36.9	7.97						
CS6P-225M/MM	225.0	29.7	7.58	37.0	8.07						
CS6P-230M/MM	230.0	29.9	7.70	37.1	8.22						
CS6P-235M/MM	235.0	30.1	7.82	37.2	8.34						
CS6P-240M/MM	240.0	30.2	7.95	37.3	8.46						
CS6P-245M/MM	245.0	30.3	8.09	37.4	8.61						
CS6P-250M/MM	250.0	30.4	8.22	37.5	8.74						
CS6P-255M/MM	255.0	30.5	8.35	37.7	8.87						
CS6P-260M/MM	260.0	30.7	8.48	37.8	8.99						
CS6P-265MM	265.0	30.9	8.61	37.9	9.11						
CS6P-270MM	270.0	31.1	8.67	38.2	9.19						
CS6P-275MM	275.0	31.3	8.80	38.3	9.31						
CS6P-160P/PE	160.0	27.6	5.81	35.5	6.56				15.00	1638X982X40	19.00 (standard) or 20.50 (PX only) or 19.50 (PM only)
CS6P-165P/PE	165.0	27.7	5.96	35.6	6.73						
CS6P-170P/PE	170.0	28.0	6.07	35.7	6.85						
CS6P-175P/PE	175.0	28.2	6.21	35.8	7.00						
CS6P-180P/PE	180.0	28.2	6.38	35.8	7.16						
CS6P-185P/PE	185.0	28.5	6.49	35.9	7.27						
CS6P-190P/PE	190.0	28.6	6.64	36.0	7.42						
CS6P-195P/PE	195.0	28.7	6.80	36.1	7.54						
CS6P-200P/PE/PX	200.0	28.9	6.93	36.2	7.67						
CS6P-205P/PE/PX	205.0	28.9	7.09	36.2	7.78						
CS6P-210P/PE/PX	210.0	29.0	7.25	36.4	7.89						
CS6P-215P/PE/PX	215.0	29.0	7.40	36.5	8.01						
CS6P-220P/PE/PX	220.0	29.2	7.53	36.6	8.09						
CS6P-225P/PE/PM/PX	225.0	29.4	7.65	36.7	8.19						
CS6P-230P/PE/PM/PX	230.0	29.6	7.78	36.8	8.34						
CS6P-235P/PE/PM/PX	235.0	29.8	7.90	36.9	8.46						
CS6P-240P/PM/PX	240.0	29.9	8.03	37.0	8.59						
CS6P-245P/PM/PX	245.0	30.0	8.17	37.1	8.74						
CS6P-250P/PM/PX	250.0	30.1	8.30	37.2	8.87						

Model Type	Maximum power Pmax<W>	Operating Voltage (Vmp) <V>	Operating current Imp <A>	Open Circuit Voltage Voc <V>	Short Circuit Current Isc <A>	Max. Series Fuse Rating <A>	Overall Dimension <mm>	Weight <Kg>			
CS6P-255P/PM/PX	255.0	30.2	8.43	37.4	9.00	15.00	1324X982X40	15.30 (Standard) or 15.50 (MM only)			
CS6P-260P/PM/PX	260.0	30.4	8.56	37.5	9.12						
CS6P-265PM	265.0	30.6	8.66	37.7	9.23						
CS6P-270PM	270.0	30.8	8.75	37.9	9.32						
CS6P-275PM	275	31.0	8.88	38.0	9.45						
CS6A-160M	160.0	23.3	6.86	29.2	7.56				15.00	1324X982X40	15.30 (Standard) or 15.50 (MM only)
CS6A-165M	165.0	23.4	7.06	29.2	7.71						
CS6A-170M	170.0	23.5	7.24	29.4	7.80						
CS6A-175M	175.0	23.6	7.41	29.5	7.92						
CS6A-180M	180.0	23.8	7.58	29.6	8.07						
CS6A-185M	185.0	23.9	7.74	29.7	8.26						
CS6A-190M/MM	190.0	24.1	7.87	29.8	8.38						
CS6A-195MM	195.0	24.2	8.04	29.9	8.56						
CS6A-200MM	200.0	24.3	8.22	30.0	8.74						
CS6A-205MM	205.0	24.5	8.38	30.2	8.90						
CS6A-210MM	210.0	24.6	8.54	30.3	9.06						
CS6A-215MM	215.0	24.7	8.7	30.4	9.22						
CS6A-135 P/PE	135.0	22.3	6.05	28.5	6.82	15.00	1324X982X40	15.30 (Standard) or 15.50 (PM only)			
CS6A-140 P/PE	140.0	22.5	6.21	28.6	7.00						
CS6A-145 P/PE	145.0	22.6	6.41	28.7	7.19						
CS6A-150 P/PE	150.0	22.9	6.56	28.8	7.35						
CS6A-155 P/PE	155.0	23.9	6.76	28.8	7.51						
CS6A-160P/PE	160.0	23.1	6.93	28.9	7.67						
CS6A-165P/PE	165.0	23.1	7.13	29.0	7.82						
CS6A-170P/PE	170.0	23.2	7.32	29.2	7.92						
CS6A-175P/PE	175.0	23.4	7.49	29.3	8.04						
CS6A-180P/PE	180.0	23.5	7.65	29.4	8.19						
CS6A-185P/PE	185.0	23.7	7.82	29.4	8.39						
CS6A-190P/PE/PM	190.0	23.9	7.95	29.6	8.50						
CS6A-195PM	195.0	24.0	8.13	29.6	8.69						
CS6A-200PM	200.0	24.1	8.30	29.8	8.87						
CS6A-205PM	205.0	24.2	8.47	29.9	9.03						
CS6A-210PM	210.0	24.3	8.63	30.0	9.19						
CS6A-215PM	215.0	24.5	8.78	30.2	9.35						
CS6X-250P	250.0	34.7	7.21	43.6	7.85				15.00	1954×982×40	27.00 (4mm Glass) or 23.00 (3.2mm Glass)
CS6X-255P	255.0	34.8	7.33	43.7	7.95						
CS6X-260P	260.0	34.9	7.45	43.8	8.04						
CS6X-265P	265.0	35.1	7.55	43.9	8.10						
CS6X-270P	270.0	35.3	7.65	44.1	8.19						
CS6X-275P	275.0	35.5	7.76	44.1	8.31						
CS6X-280P	280.0	35.6	7.86	44.2	8.42						
CS6X-285P	285.0	35.8	7.96	44.3	8.53						
CS6X-290P	290.0	35.9	8.08	44.4	8.64						
CS6X-295P	295.0	36.0	8.19	44.5	8.76						
CS6X-300P	300.0	36.1	8.30	44.6	8.87						
CS6X-305P	305.0	36.3	8.41	44.8	8.97						
CS6X-260M	260.0	35.3	7.37	44.1	7.92	15.00	1954×982×40	27.00 (4mm Glass) or 23.00 (3.2mm Glass)			
CS6X-265M	265.0	35.5	7.47	44.3	7.98						
CS6X-270M	270.0	35.6	7.58	44.4	8.07						
CS6X-275M	275.0	35.8	7.68	44.5	8.19						
CS6X-280M	280.0	36.0	7.78	44.6	8.30						
CS6X-285M	285.0	36.1	7.89	44.7	8.40						
CS6X-290M	290.0	36.3	8.00	44.7	8.51						
CS6X-295M	295.0	36.4	8.11	44.9	8.63						
CS6X-300M	300.0	36.5	8.22	45.0	8.74						

Model Type	Maximum power Pmax<W>	Operating Voltage (Vmp) <V>	Operating current Imp <A>	Open Circuit Voltage Voc <V>	Short Circuit Current Isc <A>	Max. Series Fuse Rating <A>	Overall Dimension <mm>	Weight <Kg>
CS6X-305M	305.0	36.6	8.33	45.2	8.84			
CS6X-310M	310.0	36.7	8.44	45.3	8.95			

ANNEX B: ALTERNATIVE GROUNDING METHODS

- All the requirements of paragraph 5.2 should apply to the alternative grounding methods. Each method has been qualified by at least one North-American certification body, as specified.
- For grounding methods A and B, connect module frames to each other using suitable grounding conductor with ring terminals.
- A copper terminal ring is recommended (please see below picture for reference). The d2 diameter should be 5.3mm and the size of d1 is determined by the size of the grounding cable. Proper crimping tool and method should be used to crimp the terminal onto the grounding cable. Once crimped, each terminal should be visually checked according to the following points:

- The insulator jacket is correctly crimped in the first collar
- The conductor core is correctly crimped in the second collar
- The conductor core does not run over the functional part of the ring terminal
- The ring terminal should not be bent or deformed during the crimping operation.

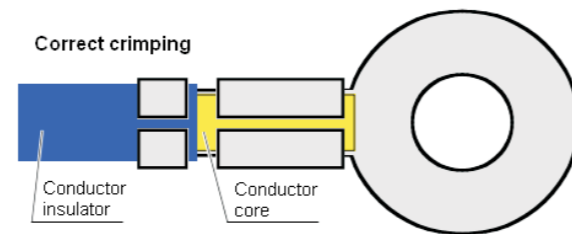

B.1 GROUNDING METHOD A: Tapping + Bolt + Ring terminal

For older modules, when diameter of the grounding holes is 4mm (INTERTEK certified).

Step1:

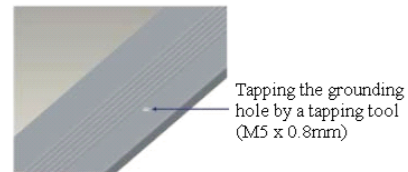

Step2:

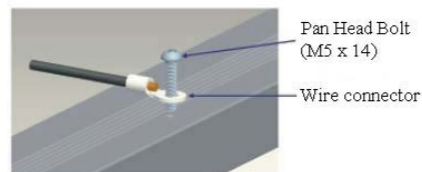

Step3:

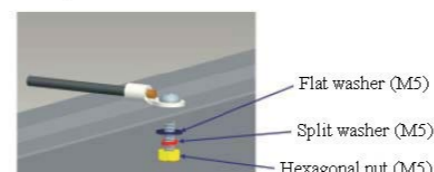

- The grounding hole should be pierced using an adequate tapping tool (M5x0.8mm).
- Secure to the grounding hole the following: the lug with stainless steel hardware including a pan head bolt (M5x14mm), a flat washer, a split washer and an hexagonal nut. Two full threads of the bolt shall engage the metal.
- A torque moment of about 3Nm should be used to fasten the grounding parts to module frame.

B.2 GROUNDING METHOD B: Bolt + K-nut + Ring terminal (copper)

When diameter of the grounding holes is 5mm (INTERTEK and CSA certified).

- Connect the grounding hardware to the grounding hole on the frame as shown in the picture.
- A K-nut is used to penetrate the frame's anodizing (protective coating) to create conductive connection.
- A torque moment of about 3Nm should be used to fasten the grounding parts to module frame.

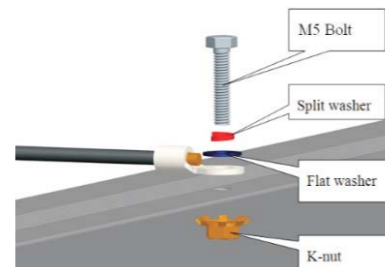

B.3 GROUNDING METHOD C: UGC-1 clips + WEEBlug 6.7

Used in conjunction with SolarMount rails from UNIRAC, no hole is requested (INTERTEK certified).

- UGC-1 grounding clips are used to create grounding path between the module frame and the UNIRAC rail. WEEBlug 6.7 assemblies are designed for use with size 6-12 AWG solid copper conductor wire, and allow connecting the system to equipment ground connector.

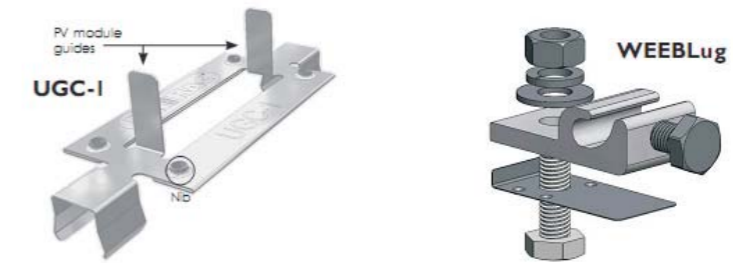

- Refer to the latest *SolarMount Rail System installation manual* from UNIRAC or to *UL-SM_En-A0 Technical note* from Canadian Solar for more information. Always follow safety procedures when installing any mounting system. Failure to follow SolarMount Rail System latest regulatory instructions will void Canadian Solar Inc. module warranty.

B.4 GROUNDING METHOD D: Rapid2+ Grounding Middle Clamps

Used in conjunction with any Schletter module mounting rail (INTERTEK certified)

- Schletter Rapid²⁺ Grounding Clamps are used to create a grounding path between the module frame and the mounting rail. An integrated grounding pin ensures bonding to the module frame by penetrating the frame coating. The Rapid²⁺ Clamp includes integrated grounding as a standard feature.
- Rapid²⁺ Grounding Clamps arrive fully assembled and ready to use. The clamps have overall dimensions of 100mm x 35.5mm (3¹⁵/₁₆ in x 1³/₈ in, respectively length by width) and are rated to 10 AWG solid copper conductor wire.
- To install, simply position the clamp over the mounting rail and insert the pointed clamp end into the rail groove. Next, tighten the Rapid Grounding Clamp using a standard drill, using a torque of no more than 14.3 Nm (10.5 ft-lbs) to fasten the clamp hardware (M8x55 Torx and M8 nut). Use of a hammer drill is not recommended.
- There are always two Rapid²⁺ Grounding Clamps in contact with any given module, thus ensuring proper and reliable bonding between the module frame and the mounting rail.



- The quantity of Rapid²⁺ Grounding Clamps is determined solely by the module layout. Clamp positions should be strictly determined according to instructions provided in Annex C of this manual.
- Refer to *Schletter Rapid²⁺ Clamp latest installation instructions* for more information and always follow safety procedures when installing any mounting system. Failure to follow Rapid²⁺ Clamp latest regulatory instructions will void Canadian Solar Inc. module warranty.

B.5 GROUNDING METHOD E: Grounding for Grizzly Bear® FR Gen II SYSTEM

Only for PanelClaw Grizzly Bear® FR Gen II mounting system (INTERTEK certified)

- All PanelClaw mounting attachments or "Claws" have been tested to and are certified under UL Subject 2703 to act as a module and racking equipment grounding conductor (EGC) device. This certification allows for the Claw to module and Claw to Support connection to serve the purpose of a copper EGC that would typically run to each module and Support. When grounding devices are installed according with the approved methodology and capacity below, the connections described above meet all the requirements outlined in NEC 690.43.

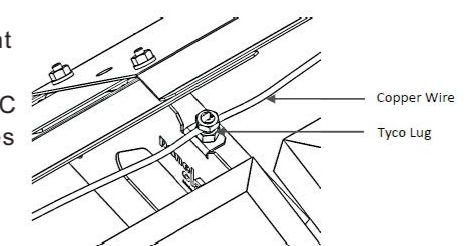

- A Tyco solid wire grounding assembly, part number 2106831, manufactured by Tyco Electronics Corporation has been pre-installed on each Grizzly Bear® Support. As you run the copper wire necessary to ground each module (not provided), ensure the same copper wire is run through every Tyco solid wire grounding assembly and secured per Tyco Electronics Corporation, LLC specifications (www.te.com). Tighten Tyco solid wire grounding assembly to torque of 5.08 Nm (45 ft-lb).
- Locating and Determining the Capacity of an EGC Bonding Jumper: Support locations within the array are required to be electrically bonded to other DC grounding paths via the use of up to a #6AWG Cu bonding jumper and a compatible UL 467 listed grounding device.

- Each Claw to Support, Claw to Claw, and Claw to module connection has been certified by UL to 120A. Determine the quantity of strings that a bonding jumper connection can accommodate based on the module series fuse rating and bonding jumper size as below. Verify that all devices used in connecting this bonding jumper can accommodate the conductor being used.

Module Series Fuse Rating / DC String Fuse Rating (A)	Size of Bare Cu Bonding Jumper (AWG)			
	#12	#10	#8	#6
	Allowable Ampacity of Conductor (A)			
10	15	50	90	120
Number of Strings per Bonding Jumper				
10	1	5	9	12
15	1	3	6	8

* refers to this combination of module series fuse rating and bonding jumper size not being allowed due to ampacity limitations. Please use a larger conductor in order to achieve an allowable combination.

ANNEX C: ALTERNATIVE MOUNTING METHODS

- All the requirements of paragraph 6.0 should apply to the alternative mounting methods, unless otherwise specified.

C.1 MOUNTING METHOD A: CLAMPING

- The mounting method has been qualified by Canadian Solar Inc but has NOT yet been certified by a third-party organization.
- Top or bottom clamping methods will vary and are dependent on the mounting structures. Follow mounting guidelines recommended by the mounting system supplier.
- Each module must be securely fastened at a minimum of 4 points on two opposite sides. The clamps should be positioned according to the authorized position ranges defined in table B-1. Install and tighten the module clamps to the mounting rails using the torque stated by the mounting hardware manufacturer. System designer and installer are responsible for load calculations and for proper design of support structure.
- Canadian Solar Inc. warranty may be void in cases where improper clamps or unsuitable installation methods are found. When installing inter-modules or end type clamps, take measures so as:
 - Not to bend the module frame
 - Not to touch or cast shadow on the front glass
 - Not to damage the surface of the frame
 - To ensure the clamps overlap the module frame by at least 5 mm.
 - To ensure the clamps overlap length is at least 40 mm.
- Clamp material should be anodized aluminum alloy. Floating type clamps are not authorized.
- Clamp positions are of crucial importance for the reliability of the installation, the clamp centerlines must only be positioned within the ranges indicated in table B-1, depending on the configuration and load.
- For configurations where the mounting rails run parallel to the clamps installation side, precautions should be taken to ensure the module frame (C-shape) overlap the rail by 15mm or more.

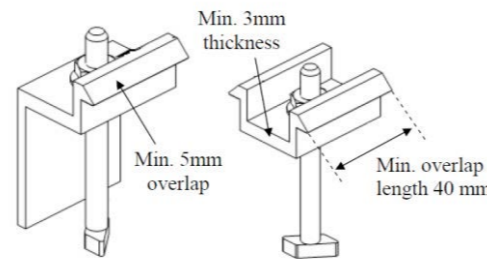

Table C-1: Authorized attachments for clamping method

	Uplift load ≤ 2400 Pa Downforce load ≤ 2400 Pa	Uplift load ≤ 2400 Pa 2400 Pa ≤ Downforce load ≤ 5400 Pa
Clamping on short side frame	Use 4 clamps on the short side, the allowed range depends on the module type. Mounting rails may run parallel or perpendicularly to the short side frame	Use 4 clamps on the short side, the allowed range depends on the module type. An additional support bar should be placed below the module.

Clamping on long side frame

Use 4 clamps on the long side, the allowed range depends on the module type.

Mounting rails may run perpendicularly or parallel to the long side frame.

Use 4 clamps on the long side, the allowed range depends on the module type.

Mounting rails may run perpendicularly or parallel to the long side frame.

Authorized range for clamping as a function of model type:

Model type	A1 range (mm)	B1 range (mm)	A2 range (mm)
CS5A	220 - 380	330 - 400	170 - 200
CS5P	220 - 390	330 - 400	220 - 270
CS6A	220 - 340	270 - 330	200 - 250
CS6P, CS5T	240 - 410	340 - 410	200 - 250
CS6X	340 - 550	410 - 490	200 - 250

C.2 MOUNTING METHOD B: INSERTION SYSTEMS

- The mounting method has been qualified by Canadian Solar Inc but has NOT yet been certified by a third-party organization.
- Insertion methods will vary and are dependent on the mounting structures. Follow mounting guidelines recommended by the mounting system supplier.
- Each module must be securely maintained through all its length on two opposite sides. Install and tighten the insertion profiles to the support structure using the hardware and instructions provided by the mounting system manufacturer. System designer and installer are responsible for load calculations and for proper design of support structure.
- Canadian Solar Inc. warranty may be void in cases where improper insertion systems or unsuitable installation methods are found. When installing insertion profiles, take measures so as:

- Not to bend the module frame
- Not to touch or cast shadow on the front glass
- Not to damage the surface of the frame
- To ensure the insertion profiles overlap the module frame by at least 10 mm.
- To ensure the module frame (C-shape) overlap the insertion profiles by at least 15 mm.
- To ensure insertion profile thickness and tolerances suits module thickness (40mm for most of Canadian Solar inc modules).

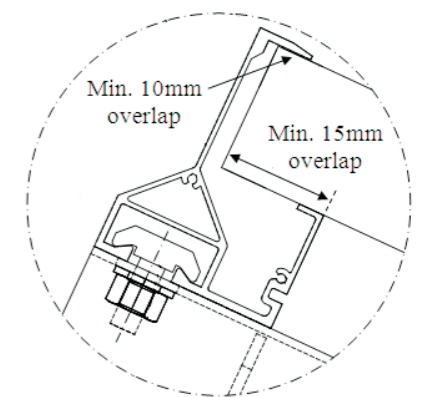

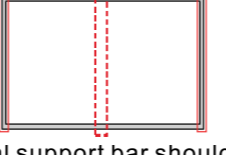

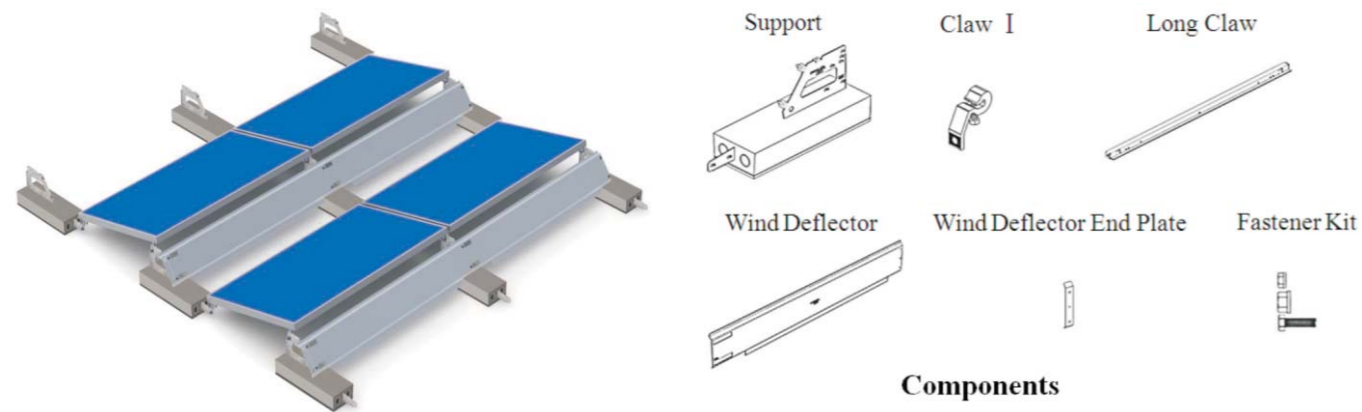

Table C-2: Authorized attachments for insertion method

	Uplift load \leq 2400 Pa Downforce load \leq 2400 Pa	Uplift load \leq 2400Pa 2400 Pa \leq Downforce load \leq 4000 Pa
Insertion profile on short side frame	Use 2 insertion profiles running parallel to the short side frame. 	Use 2 insertion profiles running parallel to the short side frame.  An additional support bar should be placed below the module. For CS6X series, installations where the downforce load can reach up to a 5400Pa are authorized
Insertion profile on long side frame	Use 2 insertion profiles running parallel to the long side frame.  For CS6X series, installations where the downforce load can reach up to a 5400Pa are authorized.	

C.3 MOUNTING METHOD C: Grizzly Bear® FR Gen II SYSTEM

- Grizzly Bear® FR Gen II System has been qualified by Intertek (ETL) to UL2703 for use with Canadian Solar Inc modules.



- All supplied hardware is specified in imperial units. Substitution of metric hardware is NOT PERMITTED and WILL VOID THE WARRANTY.
- The tools required for installation are 7/16" Wrench or socket and 9/16" Wrench or socket.
- Grizzly Bear® FR Gen II can be installed in 6 easy steps.

Step 1: Mark Array Perimeter.

Mark the array perimeter using a chalk line or similar method.

Step 2: Lay Out Supports.

Pick a starting corner on the North end of the array and place four (4) Supports as shown below, each Support should be laid out with the high end to the South and the low end to the North. Use the properly configured Spacer Stick to position the Supports, Spacer Stick length is based on the specific module used for the project.

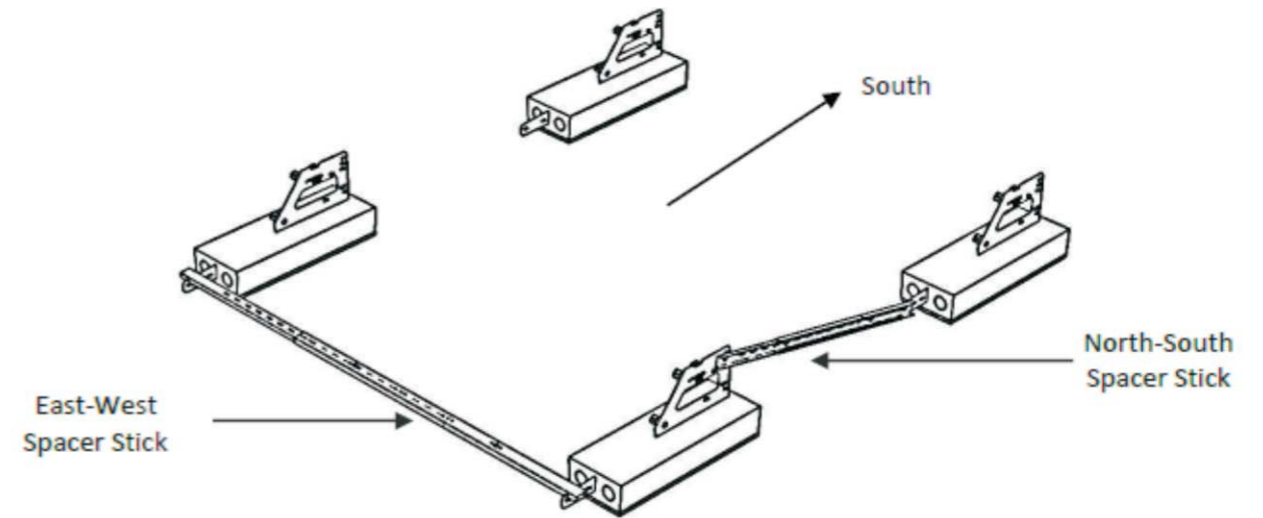

Step 3: Attach Claws to Module.

Two Claw options are used to accommodate different frame types for Canadian Solar Inc modules, Standard (Claw I), and Long (Longitudinal). The following pictures show different install methods to frame for different claws.

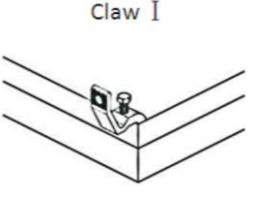
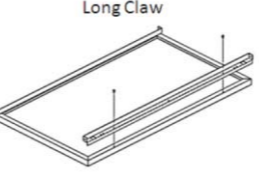
Claw	Compatible Modules	Install Methods
	CS5A series, CS5T-M, CS6P series, CS6A series, CS6X series	Place a PV module face down on protected work surface and place a Claw over the module frame flange on the short side of the module; slide to the corner and tighten the 3/8-16 x 1.25" 18-8 hex head cap screw between 24.4 and 27.1 Nm (18-20 ft-lb). Ensure that the Claw is seated up against the flanges of both the long and short sides of the module. Each module must be fitted with four (4) Claws.
	CS6X-M, CS6X-P	This Claw is used for PV modules that are not compatible with flange clamp style Claws. The Long Claw attaches at the module mounting holes using standard bolting method. Refer to paragraph 6.1 for suitable torque and fastening requirements.

Step 4: Mount Modules to Supports.

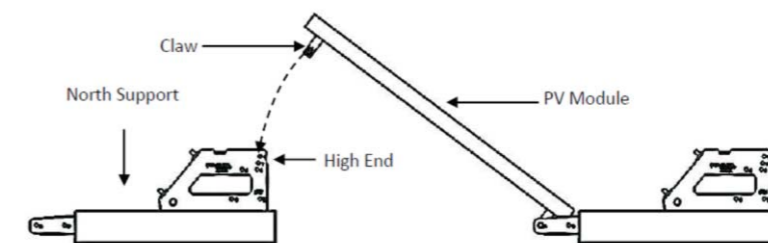

Step 5: Electrical Grounding.

Refer to B.5 GROUNDING METHOD E: Grounding for Grizzly Bear® FR Gen II SYSTEM for grounding assembly and requirements.

Step 6: Install Wind Deflectors

A Wind Deflector must be installed on the North side of every module. No Wind Deflectors should be installed on the Southern-most row of Supports (these Supports will only have modules attached at the low end of the Support).

- Refer to PanelClaw Inc Installation manual for more information and always follow latest safety procedures when installing. Failure to follow corresponding regulatory instructions will void Canadian Solar Inc. module warranty.