



# SUPERPOWER CS6K-300 | 305 | 310 | 315MS

Canadian Solar's new SuperPower modules with Mono-PERC cells significantly improve efficiency and reliability. The innovative technology offers superior low irradiance performance in the morning, in the evening and on cloudy days, increasing the energy output of the module and the overall yield of the solar system.

## KEY FEATURES



11 % more power than conventional modules



High PTC rating of up to: 91.90 %



Improved energy production due to low temperature coefficients



IP68 junction box for long-term weather endurance



Heavy snow load up to 6000 Pa, wind load up to 4000 Pa \*



linear power output warranty



product warranty on materials and workmanship

## MANAGEMENT SYSTEM CERTIFICATES\*

ISO 9001:2015 / Quality management system

ISO 14001:2015 / Standards for environmental management system

OHSAS 18001:2007 / International standards for occupational health & safety

## PRODUCT CERTIFICATES\*

IEC 61215 / IEC 61730: VDE / CE / MCS / CEC AU / INMETRO

UL 1703 / IEC 61215 performance: CEC listed (US) / FSEC (US Florida)

UL 1703: CSA / IEC 61701 ED2: VDE / IEC 62716: VDE

UNI 9177 Reaction to Fire: Class 1

IEC60068-2-68:SGS

Take-e-way



\* We can provide this product with special BOM specifically certified with salt mist, ammonia and sand blowing tests. Please talk to our local technical sales representatives to get your customized solutions.

**CANADIAN SOLAR INC.** is committed to providing high quality solar products, solar system solutions and services to customers around the world. No. 1 module supplier for quality and performance/price ratio in IHS Module Customer Insight Survey. As a leading PV project developer and manufacturer of solar modules with over 30 GW deployed around the world since 2001.

\*For detail information, please refer to Installation Manual.

## CANADIAN SOLAR INC.

545 Speedvale Avenue West, Guelph, Ontario N1K 1E6, Canada, [www.canadiansolar.com](http://www.canadiansolar.com), [support@canadiansolar.com](mailto:support@canadiansolar.com)

## ENGINEERING DRAWING (mm)

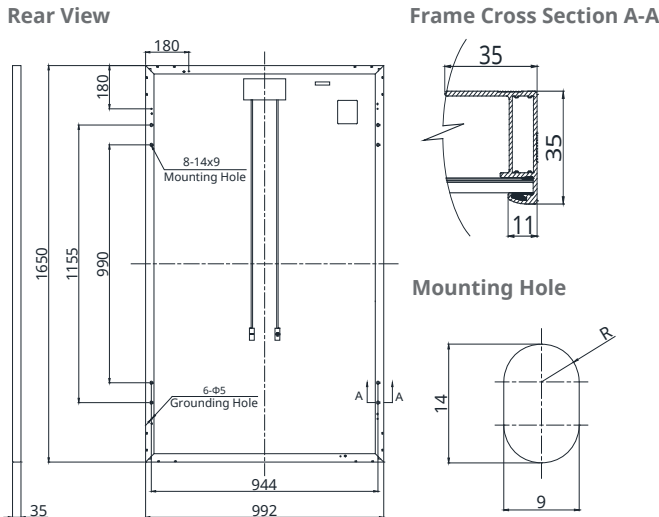

## CS6K-305MS / I-V CURVES

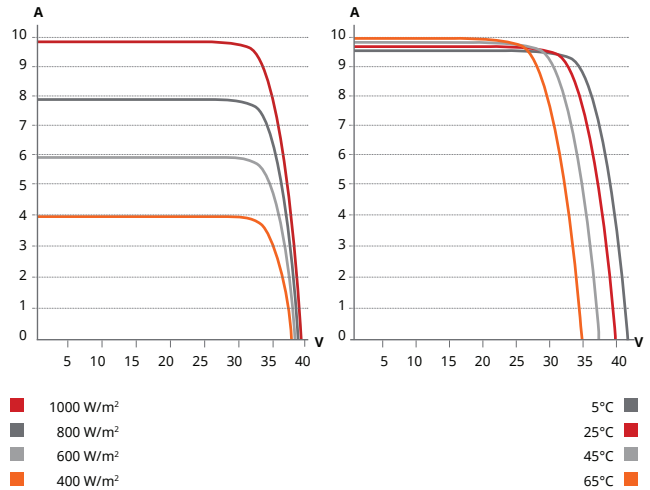

### ELECTRICAL DATA | STC\*

CS6K	300MS	305MS	310MS	315MS
Nominal Max. Power (Pmax)	300 W	305 W	310 W	315 W
Opt. Operating Voltage (Vmp)	32.5 V	32.7 V	32.9 V	33.1 V
Opt. Operating Current (Imp)	9.24 A	9.33 A	9.43 A	9.52 A
Open Circuit Voltage (Voc)	39.7 V	39.9 V	40.1 V	40.3 V
Short Circuit Current (Isc)	9.83 A	9.91 A	9.99 A	10.07 A
Module Efficiency	18.33%	18.63%	18.94%	19.24%
Operating Temperature	-40°C ~ +85°C			
Max. System Voltage	1000 V (IEC/UL) or 1500 V (IEC/UL)			
Module Fire Performance	TYPE 1 (UL 1703) or CLASS C (IEC 61730)			
Max. Series Fuse Rating	15 A			
Application Classification	Class A			
Power Tolerance	0 ~ + 5 W			

\* Under Standard Test Conditions (STC) of irradiance of 1000 W/m², spectrum AM 1.5 and cell temperature of 25°C.

### ELECTRICAL DATA | NMOT\*

CS6K	300MS	305MS	310MS	315MS
Nominal Max. Power (Pmax)	222 W	226 W	230 W	233 W
Opt. Operating Voltage (Vmp)	30.0 V	30.2 V	30.4 V	30.6 V
Opt. Operating Current (Imp)	7.40 A	7.48 A	7.55 A	7.63 A
Open Circuit Voltage (Voc)	37.2 V	37.4 V	37.6 V	37.8 V
Short Circuit Current (Isc)	7.93 A	7.99 A	8.06 A	8.12 A

\* Under Nominal Module Operating Temperature (NMOT), irradiance of 800 W/m², spectrum AM 1.5, ambient temperature 20°C, wind speed 1 m/s.

### PERFORMANCE AT LOW IRRADIANCE

Excellent performance at low irradiance, with an average relative efficiency of 97.5 % for irradiances between 200 W/m² and 1000 W/m² (AM 1.5, 25°C).

\* The specifications and key features contained in this datasheet may deviate slightly from our actual products due to the on-going innovation and product enhancement. Canadian Solar Inc. reserves the right to make necessary adjustment to the information described herein at any time without further notice.

### MECHANICAL DATA

Specification	Data
Cell Type	Mono-crystalline, 6 inch
Cell Arrangement	60 (6 × 10)
Dimensions	1650 × 992 × 35 mm (65.0 × 39.1 × 1.38 in)
Weight	18.2 kg (40.1 lbs)
Front Cover	3.2 mm tempered glass
Frame Material	Anodized aluminium alloy
J-Box	IP68, 3 diodes
Cable	4.0 mm² (IEC), 12 AWG (UL), 1000 mm (39.4 in)
Connector	T4 series
Per Pallet	30 pieces
Per Container (40' HQ)	840 pieces

### TEMPERATURE CHARACTERISTICS

Specification	Data
Temperature Coefficient (Pmax)	-0.39 % / °C
Temperature Coefficient (Voc)	-0.29 % / °C
Temperature Coefficient (Isc)	0.05 % / °C
Nominal Module Operating Temperature (NMOT)	42 ± 3 °C

### PARTNER SECTION



## CANADIAN SOLAR INC.

545 Speedvale Avenue West, Guelph, Ontario N1K 1E6, Canada, [www.canadiansolar.com](http://www.canadiansolar.com), [support@canadiansolar.com](mailto:support@canadiansolar.com)