

FEATURES & APPLICATIONS

- ❖ Inexpensive 2 wire to 3 wire start controller for electric start high speed gas generators.
- ❖ Optimized for use with Outback Invertors.
- ❖ Supports three types of 3 wire generator control (momentary, maintained, ignition).
- ❖ Fixed Crank time, Over and Under Hz shutdown thresholds.
- ❖ Optional Battery charging with fixed set points.
- ❖ Remote Run and Fault indication included.
- ❖ Totally sealed for harsh environment operation

DESCRIPTION

The GSCM-mini is a micro-processor based generator start-stop module, designed to auto start-stop high speed gas generators needing a 3 wire connection from a 2 wire manual start command. It automatically disconnects the starter when a minimum generator AC Hz. output is measured, it can monitor the generator’s output, shutting it down if either an over or under Hz condition is detected. LEDs are flashed to indicate the cause of the shutdown. Manually resetting the GSCM-mini by removing the power, removes the lockout and allows the generator to restart if called to do so. The GSCM-mini is powered by 12VDC from the generator battery, and can monitor the battery voltage and start the generator to charge it’s own battery. All Thresholds are fixed. The GSCM-mini is a limited function controller, part of the GSCM family. If adjustability is required use the GSCM full function Generator Start Control Module.

THREE MODES OF RELAY OPERATION

The GSCM-mini’s two relay contacts can be configured for three types of three wire start/stop hook-up configurations; momentary, maintained and Ignition for Honda®, Onan®, Yamaha®, and other brands of generators. This is accomplished with an optional jumper on terminal 6.

Momentary Start Contact Option #1, terminal 6, has No Connection. The GSCM-mini defaults to a momentary crank operation for those generators that use two momentary push button switches to start and stop the generator. K1 cranks the Starter and K2 momentarily grounds the magneto. See Section 1 for operation description.

Maintained Start Contact Option #2, terminal 6, is grounded. The GSCM-mini changes to a maintained start operation for generators that use a maintained closed contact to start (K1). The generator is stopped by opening K1 and closing K2 contact, momentarily grounding the magneto. See Section 2 for operation description.

Ignition Key Switch Start Contact Option #3, terminal 6, is connected to B+ (12VDC). The GSCM-mini simulates an automobile ignition switch, K2 closes, maintains a closed ignition contact for the generator to run and K1 closes momentarily to crank the starter motor. and de-energizes when the start signal is removed. The K1 relay operates in a momentary crank configuration. See section 3 for operation description.



LED INDICATION DESCRIPTION

The GSCM-mini has six indication LEDs. The **Start LED**, blinks every 5 seconds to indicate ready for a start signal, blinks every 2.5 sec. to indicate running in Auto Start mode, ‘On’ continuously indicates running in Manual Start mode. The **Generator Hz LED**, blinks to indicate over/under Hz Fault and Start Failure do to Maximum crank attempted. A slow blink indicates an under Hz condition, a fast blink indicates an over Hz condition. ‘On’ continuously indicates AC present in a non run condition. A double blink indicates a start failure condition. The **Run LED**, ‘On’ continuously indicates a valid Run signal from the generator. The **Fault LED**, ‘On’ indicates a Fault condition has occurred and GSCM is in lockout and must be reset. The **K1 and K2 LEDs** indicate the relay status.

OPERATIONAL THRESHOLDS

The GSCM-mini has fixed operational thresholds. Those are: Crank delay, Maximum Crank time, Crank Hz. Disconnect, Under Speed Shutdown, Over Speed Shutdown, and auto detects the Battery voltage to determine the auto start and auto stop threshold values for 12V, 24V, and 48V battery systems. If adjustability is required then use the GSCM full function control module.

Crank delay:	5 seconds
Maximum Crank:	20 seconds
Crank Disconnect:	45Hz
Under Speed Shutdown:	55Hz
Over Speed Shutdown:	65Hz
Auto Start/Stop	
Thresholds:	Start Stop
12V system	11.5V 13.8V Standard
24V system	23.0V 27.6V Call for option
48V system	46.0V 55.2V Call for option

Relay Configuration:: Open input = Momentary Crank (TERMINAL 6)
 Grounded input = Maintained Crank
 B+ (12VDC) input = Ignition & Crank

Fault Detection: Start Failure, (3 attempts)
 Over Hz condition (10 seconds)
 Under Hz condition (10 seconds)

GSCM-mini WIRING DIAGRAM AND CONTROLLER CONFIGURATION

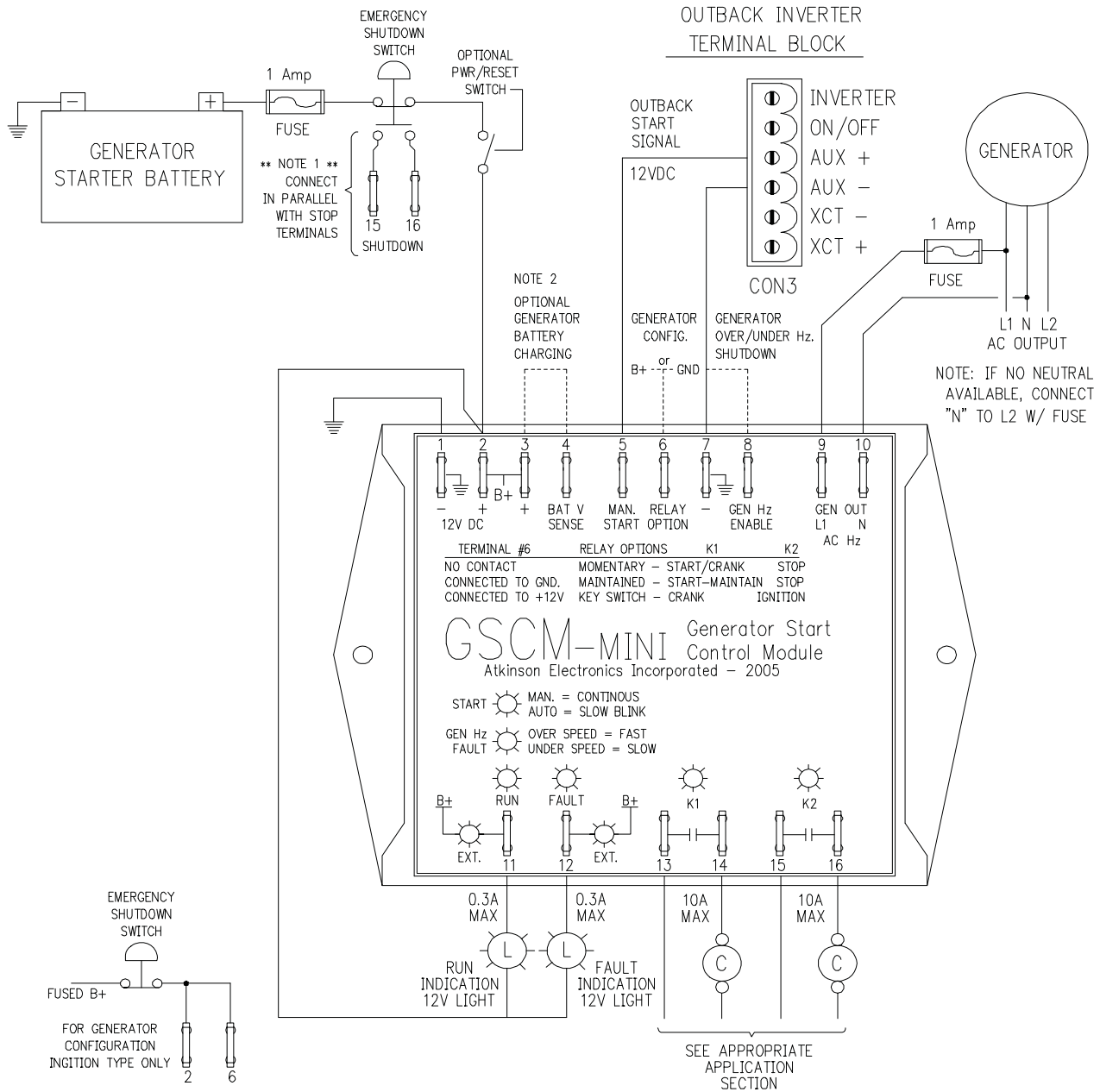

NOTE 1
IF THE GENERATOR THREE (3) WIRE START/STOP CONNECTION REQUIRES AN IGNITION (MAINTAINED CONTACT CLOSER TO RUN) AND A CRANK CONTACT TO START THE GENERATOR, THE EMERGENCY SHUTDOWN SWITCH ONLY NEEDS A SINGLE CONTACT TO DISCONNECT THE POWER FROM THE GSSM. REMOVING POWER CAUSES THE STOP/IGN RELAY TO DE-ENERGIZE SHUTTING DOWN THE GENERATOR.

NOTE 2
THE BATTERY VOLTAGE SENSE INPUT IS USED TO PROVIDE AN AUTO START FOR THE GENERATOR TO CHARGE IT'S OWN CRANK BATTERY. THE OUTBACK INVERTER ALREADY MONITORS IT'S OWN BATTERY BANK AND PROVIDES A START SIGNAL TO THE GSSM TO START THE GENERATOR TO CHARGE 12V, 24, OR 48V BATTERY BANKS.

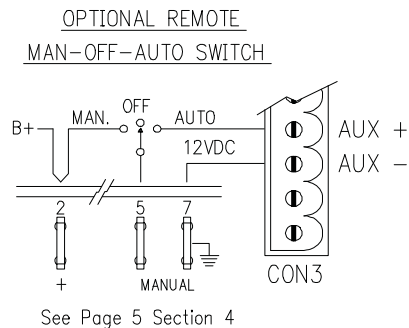

OPTION #1 MOMENTARY START CONTACT - TYPICAL GENERATOR W/ STARTER CONTROL BOX

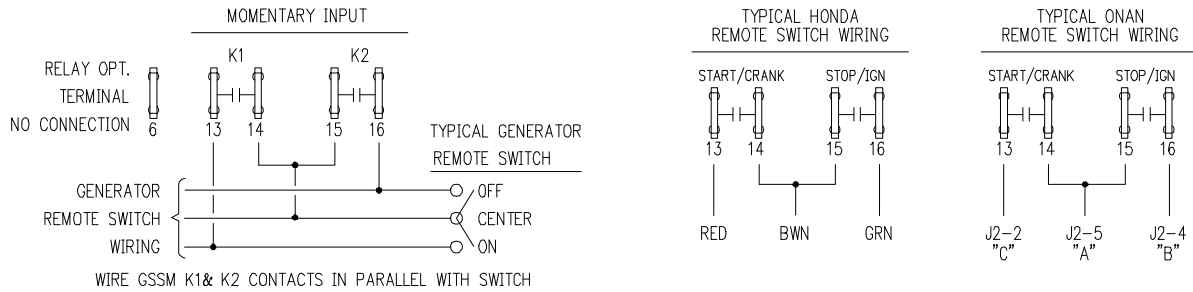

The K1 relay is used to switch the start/crank input which is looking for a momentary signal and opens when the generator has reached 50Hz, or half speed. The K2 relay provides a momentary “stop” signal until the generator AC Hz has dropped to zero. For GSCM-mini operational sequence details see Page 4, Section - 1

OPTION #2 MAINTAINED START CONTACT TYPICAL GENERATOR W/ STARTER CONTROL BOX

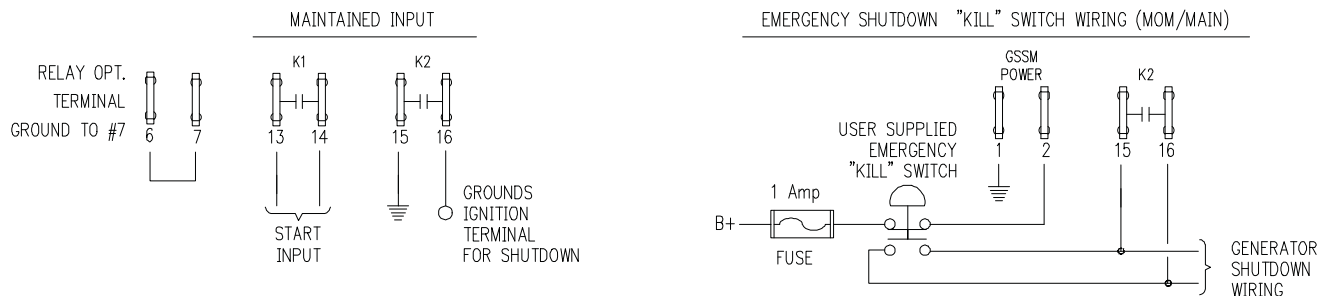

The K1 relay provides a continuous run signal for generators requiring a “maintained” start signal. The K2 relay provides a momentary “stop” signal until the generator AC Hz has dropped to zero. For GSCM-mini operational sequence details see Page 4, Section - 2

A double pole “kill switch” wired and installed by the user, stops the generator instantly in emergency situations such as a fuel spill. One switch pole (N.C.) kills power to the GSCM-mini opening all relays. The other switch pole (N.O.) shorts out the magneto for an instant stop.

OPTION #3 IGNITION KEY SWITCH TYPE START CONTACT TYPICAL GENERATOR W/ STARTER CONTROL



The K1 relay is used to switch the starter input which is looking for a momentary signal and opens when the generator has reached 50Hz, or half speed. The K2 relay provides a continuous run signal for generators requiring a “maintained” ignition signal. When the GSCM-mini no longer receives a run command signal (terminal 5 or batteries fully charged), K2 relay opens telling the generator to shutdown. For GSCM-mini operational sequence details see Page 5, Section - 3

A single pole “kill switch” wired and installed by the user, stops the generator instantly in emergency situations such as a fuel spill. One switch pole (N.C.) kills power to the GSCM-mini opening all relays shutting down the ignition switch type generators.

The GSCM-mini indicates that it is ready to receive a start signal by blinking the start LED once every 5 seconds. The CONFIGURATION terminal 6 has NO connection, configuring the GSCM-mini for momentary start sequence. The start signal is created by closing a switch connected between the manual start terminal 5 to B+ terminal 3 or connecting the Aux + and Aux - terminals from an Outback Inverter to terminal 5 (start) and terminal 7 (ground). The module may also start in automatic mode based on a battery voltage (see Section-6 for Automatic start for battery charging). If the GSCM-mini detects an AC signal from the generator before a start command is given (ie: the generator is already running) it will not execute a start sequence until the AC Hz. signal has been rectified, and will turn ON the Generator Hz LED. The generator starting sequence is as follows.

1. The start LED blinks once every 5 seconds to indicate that the GSCM-mini is in a "Ready" mode. When a manual signal is received, the start LED lights continuously. After a 2 second delay, K1 relay closes to crank the starter, and remains closed until either the generator starts or the maximum cranking time period (20 seconds) is reached.
2. If the generator fails to start after the 20 seconds cranking period, K1 relay opens for a resting period of 40 seconds. The K1 relay then closes again cranking the starter until the maximum cranking time is reached or the generator starts.
3. If the generator fails to start after 3 cranking attempts with the associated resting periods, then K2 relay closes for 5 seconds, then the Gen Hz LED does a double blink, the Fault LED turns ON and the GSCM-mini enters the Max. Crank lockout condition. This lockout condition remains until the GSCM-mini is reset by removing power from terminal 2 (see GSCM-mini wiring diagram, previous page) and reconnecting power. The GSCM-mini will then clear the lockout condition, and enter "Ready" mode with the Start LED blinking Every 5 seconds.
4. When the generator starts, K1 relay immediately opens, stopping the cranking. A valid run condition is determined by the generator AC output frequency exceeding the crank disconnect setting of 45Hz and is indicated with the Run LED turned On..
5. If the generator starts but shuts down after a few seconds due to a fuel problem, etc. the start sequence will revert to the "Ready" mode after a 60 second delay. During this delay the start LED will blink rapidly. The GSCM-mini will then try to start the generator again in manual mode or after a 5 minute delay period in auto-start mode.
6. When a run condition is detected, the GSCM-mini turns ON the Run LED and transistor output (remote run lamp) and after a 60 second generator stabilization period begins monitoring the AC Hz signal for over/under Hz condition.
7. If the generator starts but shuts down after the 60 seconds stabilization period, due to a fuel problem, etc. the GSCM-mini blinks the Gen Hz LED for an Under Hz condition , after 60 seconds the Run LED turns Off, Fault LED turns On, and K2 relay energizes for 5 seconds. The GSCM-mini enters a Fault shutdown lockout condition. A power down reset is required to clear the lockout condition.
8. The generator continues running until one of the following occurs: the manual start signal is no longer received, the auto battery charge voltage has been reached while running in Auto Charge Mode, an Over or Under Hz condition occurs (If Gen. Hz. Shutdown is enabled) or the generator runs out of gas. (No run time limit)
9. During shutdown, K2 relay closes to ensure shutdown of the generator by grounding out the ignition, etc. It remains closed until the AC Hz signal from the generator has gone to zero for 5 seconds ensuring that the generator has shutdown.
10. The generator remains off until another start signal is received.

GSCM-mini MAINTAINED STARTING SEQUENCE (Relay Option #2)***SECTION - 2***

The CONFIGURATION terminal 6 has been connected to ground (terminal 7), configuring the GSCM-mini for maintained start sequence. The GSCM-mini is then powered by connecting B+ (12.0 VDC) to terminal 2. After 10 seconds the GSCM-mini indicates that it is ready to receive a start signal by blinking the start LED once every 5 seconds. The generator starting sequence is as follows.

1. The start LED blinks once every 5 seconds to indicate that the GSCM-mini is in a "Ready" mode. When a manual start signal is received, the start LED lights continuously. After a 2 second delay, K1 relay closes to start the generator. The K1 relay remains closed until either the start signal is removed or the maximum cranking time of 1 minute is reached.
2. If the generator fails to start after a single 1 minute start period, GSCM-mini enters its Shutdown Routine, then the Gen Hz LED does a double blink, the Fault LED turns ON and the GSCM-mini enters the Max. Crank lockout condition. This lockout condition remains until the GSCM-mini is reset by removing power from terminal 2 (see GSCM-mini wiring diagram), and reconnecting power. The GSCM-mini will then clear the lockout condition, and enter "Ready" mode with the Start LED blinking Every 5 seconds.
3. When the generator starts, K1 relay remains energized. A valid run condition is determined by the generator AC output frequency exceeding the crank disconnect setting of 45Hz and is indicated by the Run LED being turned ON.
4. If the generator starts but shuts down after a few seconds due to a fuel problem, etc. The GSCM-mini goes thru it's Shutdown Routine then re-enters "Ready" mode after a 60 second delay. During this delay the start LED will blink rapidly. The GSCM-mini will then try to start the generator again in manual mode or after a 5 minute delay period in auto-start mode.

GSCM-mini MAINTAINED STARTING SEQUENCE continued**SECTION - 2**

5. When a run condition is detected, the GSCM-mini turns ON the Run LED and open collector transistor output (remote run lamp) and after a 60 second generator stabilization period begins monitoring the AC Hz signal for over/under Hz condition.
6. If the generator starts but shuts down after the 60 seconds stabilization period, due to a fuel problem, etc. the GSCM-mini blinks the Gen Hz LED for an Under Hz condition, after 60 seconds the Run LED turns Off, Fault LED turns On, and K2 relay energizes for 5 seconds. The GSCM-mini enters a Fault shutdown lockout condition. A power down reset is required to clear the lockout condition.
7. The generator continues running until one of the following occurs: the manual start signal is no longer received, the auto battery charge voltage has been reached while running in Auto Charge Mode, an Over or Under Hz condition occurs (If Gen. Hz. Shutdown is enabled) or the generator runs out of gas. (No run time limit)
8. Shutdown Routine, K1 de-energizes, then ½ second later K2 relay energizes, remains closed until the AC Hz signal from the generator goes to zero for 5 seconds ensuring generator shutdown.
9. The generator remains off until another start signal is received.

GSCM-mini IGNITION/CRANK STARTING SEQUENCE (Relay Option #3)**SECTION - 3**

The CONFIGURATION terminal 6 has been connected to B+ (terminal 3), configuring the GSCM-mini for ignition/crank start sequence. The GSCM-mini is then powered by connecting B+ (+12 VDC) to terminal 2. After 5 seconds the GSCM-mini indicates that it is ready to receive a start signal by blinking the start LED once every 5 seconds. The starting sequence is as follows.

1. The start LED blinks once every 5 seconds to indicate that the GSCM-mini is in a "Ready" mode. When a manual signal is received, the start LED lights continuously. After a 2 second delay, K2 relay energizes and remains energized until the start signal is either removed or the generator fails to start after 3 attempts. K1 relay closes to crank the starter. The K1 relay remains closed until either the generator starts or the maximum cranking time period (20 seconds) is reached.
2. If the generator fails to start after the 20 seconds cranking period, K1 relay opens for a resting period of 40 seconds. The K1 relay then closes again cranking the starter until the maximum cranking time is reached or the generator starts.
3. If the generator fails to start after 3 cranking attempts with the associated resting periods then K2 relay de-energizes and the GSCM-mini enters its Shutdown Routine, then the Gen Hz LED does a double blink, the Fault LED turns ON and the GSCM-mini enters the Max. Crank lockout condition. This lockout condition remains until the GSCM-mini is reset by removing power from terminal 2 (see GSCM-mini wiring diagram) and reconnecting power. The GSCM-mini will then clear the lockout condition, and enter "Ready" mode with the Start LED blinking Every 5 seconds.
4. When the generator starts, K1 relay immediately opens, stopping the cranking. A valid run condition is determined by the generator AC output frequency exceeding the crank disconnect setting of 45Hz.
5. If the generator starts but shuts down after a few seconds due to a fuel problem, etc. the start sequence will revert to the "Ready" mode after a 60 second delay. During this delay the start LED will blink rapidly. The GSCM-mini will then try to start the generator again in manual mode or after a 10 minute delay period in auto-start mode.
6. When a run condition is detected, the GSCM-mini turns ON the Run LED and open collector transistor output (remote run lamp) and after a 60 second generator stabilization period begins monitoring the AC Hz signal for over/under Hz condition.
7. If the generator starts but shuts down after the 60 seconds stabilization period, due to a fuel problem, etc. the GSCM-mini blinks the Gen Hz LED for an Under Hz condition, after 60 seconds the Run LED turns Off, Fault LED turns On, and K2 relay energizes for 5 seconds. The GSCM enters a Fault shutdown lockout condition. A power down reset is required to clear the lockout condition.
8. The generator continues running until one of the following occurs: the manual start signal is no longer received, the auto battery charge voltage has been reached while running in Auto Charge Mode, an Over or Under Hz condition occurs (If Gen. Hz. Shutdown is enabled) or the generator runs out of gas. (No run time limit)
9. When the manual start signal is removed, K2 relay de-energizes opening the ignition circuit shutting down the generator. The GSCM-mini then monitors the Generator AC Hz input to watch for a zero Hz condition before returning to "Ready" mode. If the AC signal remains the GSCM-mini's Generator HZ LED turns on indicating AC Hz. Signal still present and will not return to Ready mode until the AC signal goes to zero. Once it goes to zero the GSCM-mini returns to "Ready" mode.
10. The generator remains off until another start signal is received.

GSCM-mini WITH A MANUAL/OFF/AUTO SWITCH OPTIONS**SECTION - 4**

The Manual start signal is created by connecting terminal 5 (man. Start) to terminal 3 (B+12VDC) through a Power/Reset Switch (see GSCM-mini wiring diagram). It may also be generated by an Outback Inverter using the AUX+/- connections on the remote terminal block. The Outback provides a switched +12VDC signal for the GSCM-mini's manual start input. An optional Manual-Off-Auto switch can be installed to provide user flexibility for manual starts, resets, turning the unit off, or Auto starting from Inverter. (see GSCM-mini's wiring diagram, lower right hand corner).

The GSCM-mini detects three (3) fault shutdown conditions (over/under Hz. detection not enabled until the generator has been running for 60 seconds) and will shutdown the generator after 10 continuous seconds of Hz. fault condition, locking it out until a power down reset and power back up. The Fault open collector transistor output (terminal 12) will energize a user supplied remote lamp or DC relay (not exceeding 300 milliamp coil current) whenever a fault shutdown occurs and will de-energize the relay when the fault is reset. The shutdown conditions are as follows:

1. Failure to start with 3 cranking attempts (see Section-1:3, 2:2, & 3:3). The Gen. Hz Shutdown LED does a double blink and Fault LED On continuously.
2. High frequency (over Hz.) condition. The generator AC frequency is monitored on terminals 9 and 10. If the Gen. Hz. enable terminal #8 is grounded and the generator output frequency exceeds the 65 Hz fixed threshold for 10 seconds, the generator shuts down and the Generator Hz shutdown LED blinks rapidly. The "Generator Hz" LED blinks during this 10 second period.
3. Low frequency (under Hz.) condition. If the Gen. Hz. enable terminal #8 is grounded and the generator output frequency remains below the 55 Hz fixed threshold for 10 seconds, the generator shuts down and the Generator Hz shutdown fault LED blinks slowly. The "Generator Hz" LED blinks during this 10 second period.

AUTOMATIC STARTING FOR BATTERY CHARGING**SECTION - 6**

The GSCM-mini can monitor either the generator battery voltage or a battery bank voltage and Automatically start/stop the generator based on battery voltage. This is accomplished by connecting the battery voltage to the battery sense input (terminal 4). The GSCM-mini monitors a battery voltage range of 0 to 60V DC and automatically determines the start and stop set point based on battery voltage (12, 24, or 48VDC). Below 16VDC - 12V thresholds, between 16 to 32V - 24V thresholds, above 32V - 48V thresholds. This mode is disabled if the voltage on terminal 4 is less than 6V, (no connection).

1. The GSCM-mini monitors the battery sense input and when the battery voltage drops below the start threshold the Start LED begins blinking (three fast blinks with 2 second off time). When the battery sense voltage has remained below the start threshold for 5 continuous minutes the Auto start sequence begins. If the battery voltage rises above the start threshold during the 5 minute period the 5 minute timing cycle starts over. (Temporary battery voltage fluctuations such as instantaneous inverter loads will not start the GSCM.) The start LED blinks every 3 seconds while the GSCM-mini is running the generator in auto-start battery charging mode.
2. The GSCM-mini starts the generator as described in sections 1: momentary start, 2: maintained start, or 3: ignition start.
3. The GSCM-mini shuts down the generator (as described in Sections 1, 2, or 3) whenever the battery voltage exceeds the stop threshold for 10 minutes. The Start LED blinks (three fast blinks with 2 second off time) during this 10 minute period. The GSCM-mini will exit the 10 minute period and shutdown the generator if the battery voltage exceeds the stop point by +1.0V (for a 12V system, 2V for 24V system, voltages are proportional). The generator remains off until the battery voltage drops below the start threshold voltage.
4. There is no maximum runtime shutdown in either manual or auto start.
5. If the user wishes to manual-start the generator from a separate pressure switch, level switch, thermostat or inverter start contact, etc., the battery voltage is fed through the switch (pressure switch etc.) contact to Manual start terminal 5. Closing the contact will cause the GSCM-mini to start the generator. Some invertors provide a switch 12VDC signal to start the generator. This switched voltage can be connected directly to the manual start terminal 5 and ground terminal 7. (See GSCM-mini wiring diagram for hook-up).

GENERATOR EMERGENCY SHUTDOWN WITH THE GSCM-mini**SECTION - 7**

The GSCM-mini Generator Start Stop module is **NOT AN EMERGENCY SHUTDOWN DEVICE!!** If the manual start signal is removed the generator will go through a normal shutdown which may take up to 15 seconds to completely shutdown the generator

A RECOMMENDED EMERGENCY SHUTDOWN SOLUTION is to install a separate "Kill" switch and label it as such. The recommended wiring is shown on page-2 of these instructions and also in Application 1. Disconnecting the power to the GSCM-mini module will force the relays to open. This will shutdown generators that require a maintained run signal from K1 relay. However this also prevents the K2 relay from closing to shutdown those generators requiring a momentary stop signal. Using a double pole "Kill" switch and wiring the second pole in parallel with the K2 relay terminals will force the generator to stop in an emergency situation such as a fuel spill. (see note 1 on wiring diagram, page 2, for Ignition/crank emergency shutdown option).

LED DESCRIPTION (WHAT THEY MEAN)

SECTION - 8

1. **Start:** one blink every 5 seconds = Ready mode, looking for a start signal;
 one blink every 2.5 seconds = auto start mode operation;
 one blink every other second= auto start/stop period,
 continuous = manual start signal received;
 fast blink = 60 second delay after start signal removed before generator started;
2. **Generator Hz Shutdown:** fast blink = over speed condition;
 slow blink = under speed condition;
 double blink = Maximum Crank attempts reached, Failed to Start;
 continuous = start function disabled, AC Hz detected before starting;
3. **Run:** continuous = GSCM has a valid run signal from generator;
4. **Fault:** continuous = GSCM is in a fault condition and requires a reset;
5. **K1 & K2:** continuous = Status of K1 and K2 Relays "ON"

SPECIFICATIONS

SECTION - 9

SIZE & WEIGHT:	5.13" L x 2.853" W x 1.35" H, 20 OZ	RELAY CONFIG.:	Open input = Momentary Crank (TERMINAL 6)									
MOUNTING:	2 screws through tabs	FREQUENCY INPUT:	120-240V AC 0-100 Hz									
POWER:	12VDC only Quiescent current < 10mA Relay current < 25mA ea.	OUTPUT RATINGS:	Qty. (2) 10 Amp 28V DC, 240V AC Relay contacts Qty. (2) Open collector NPN transistors, Max. 300mA each									
MANUAL INPUT:	B+ (12VDC) input = on condition Open input = off condition	FAULT DETECTION:	Start Failure, (3 attempts) Over Hz condition (10 seconds) Under Hz condition (10 seconds)									
BATTERY INPUT:	0-60V DC	AMBIENT TEMP:	-40 to 85°C									
AUTO START/STOP THRESHOLD:	<table border="0"> <tr> <td>12V System</td> <td>Start 11.5V,</td> <td>Stop 13.5V</td> </tr> <tr> <td>24V System</td> <td>23.0V,</td> <td>27.0V</td> </tr> <tr> <td>48V System</td> <td>46.0V,</td> <td>54.0V</td> </tr> </table>	12V System	Start 11.5V,	Stop 13.5V	24V System	23.0V,	27.0V	48V System	46.0V,	54.0V		
12V System	Start 11.5V,	Stop 13.5V										
24V System	23.0V,	27.0V										
48V System	46.0V,	54.0V										

APPLICATION 2 - REMOTE RV GENERATOR START CONSOLE REPLACEMENT

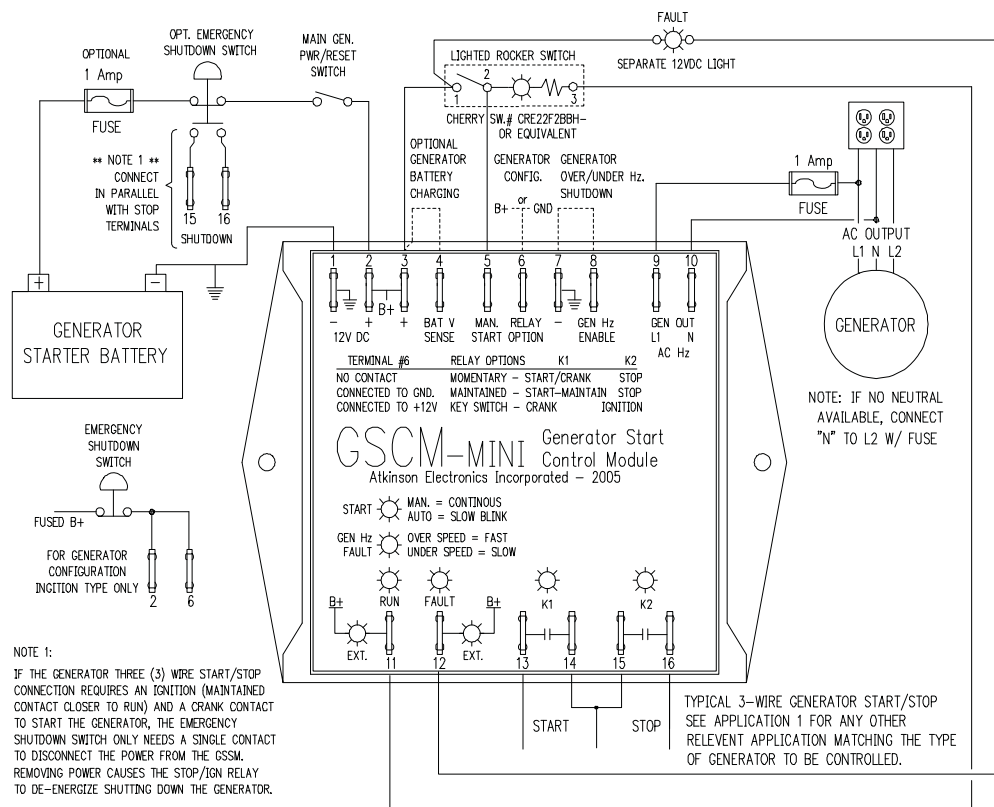

The GSCM mini can be used to replace a typical remote generator control console, that is mounted on the dash of a motorhome. Instead of a large console and cable, use a small 16 to 18 gauge 4 wire signal cable, an on-off switch with built in light and a separate 12vdc fault light. When the remote switch is turned on, the GSCM mini starts the generator. After the generator starts and comes up to speed the "run" LED lights on the GSCM mini and lights the remote start switch light. If the generator fails to start or fails while commanded to run the "fault" LED on the GSCM mini lights along with the remote fault 12vdc light. Turning off the power to the GSCM mini resets the fault condition and it is ready to receive another start command.

LIMITED WARRANTY

Atkinson Electronics, Inc. gives this express warranty (along with extended warranty endorsements, where applicable) in lieu of all other warranties, express or implied, including (without limitation), warranties of merchantability and fitness for a particular purpose. This constitutes Atkinson Electronics, Inc.'s sole warranty and obligation with regard to our products as well as the Customer's sole remedy.

Atkinson Electronics, Inc. expressly disclaims all liability and responsibility for any special, indirect or consequential damages or any further loss of any kind whatsoever resulting from the use of our product. The Customer's sole and exclusive remedy and the limit of Atkinson Electronics, Inc.'s liability for any loss whatsoever, shall not exceed the purchase price paid by the Customer for the product to which a claim is made.

Countries or States that do not allow limitations of incidental or consequential damages or on how long an implied warranty lasts, the above limitations may not apply to you. This warranty gives you specific legal rights and you may also have other rights which vary from State to State or Country to Country.

All products manufactured by Atkinson Electronics, Inc. are warranted to be free from defects in material and workmanship in accordance with and subject to the following terms and conditions:

1. This warranty is limited to the original customer only. It cannot be transferred or assigned to third parties unless the intent to transfer to a third party is expressly indicated in a purchase order and/or warranty processing arrangements have been agreed upon in writing by Atkinson Electronics, Inc.
2. Atkinson Electronics, Inc. will correct any defects in material or workmanship which appear within two (2) years from the date of shipment by Atkinson Electronics, Inc. (or its authorized distributors) to the original Customer. Atkinson Electronics, Inc. will repair or replace, at our option, any defective products, provided that our inspection discloses that such defects developed under normal and proper use. This warranty does not extend to goods subjected to misuse, neglect, accident or improper installation, or to maintenance or repair of products which have been altered or repaired by anyone except Atkinson Electronics, Inc., unless otherwise stated in writing.

Atkinson Electronics, Inc. will correct any defects in material or workmanship of OEM products (designated as such in our catalog or web site) which appear within two (2) years from the product date code or from the factory invoice date, whichever is later.

3. An appropriate charge (25% of product list price) may be made for testing, repairs, replacement and shipping for a returned product which is not defective or found to be defective as the result of improper use, maintenance or neglect.
4. Atkinson Electronics, Inc. will not accept responsibility for any invoiced goods or services that are not covered by an Atkinson Electronics, Inc. written purchase order. Under no circumstances does Atkinson Electronics, Inc. agree to pay for labor or other related expenses associated with the troubleshooting and/or repair of our product without prior specific written authorization.
5. Information in our descriptive literature is based on product specifications that are current at the time of publication. Product specifications, design and descriptive literature are subject to change as improvements are introduced. Although we announce changes as they occur, we cannot guarantee notification to every Customer. Atkinson Electronics, Inc. warrants delivered products to conform to the most current specifications, design and descriptive literature.

This warranty policy may be expanded or limited, for particular categories of products or Customers, by information sheets published as deemed appropriate by Atkinson Electronics, Inc.

